



The
AIRCRAFT ENGINE
AND ITS
Operation

P R A T T & W H I T N E Y A I R C R A F T
D I V I S I O N O F U N I T E D A I R C R A F T C O R P O R A T I O N
E A S T H A R T F O R D C O N N E C T I C U T

STRAMA

Part No. PWA 109702

PWA OI. 100

THE AIRCRAFT ENGINE AND ITS OPERATION



INSTALLATION ENGINEERING

February, 1955

First Printing, April 1946
Reprinted with Revisions, May 1947
Reprinted with Revisions, January 1949
Reprinted with Revisions, August 1951
Reprint with Revisions, January 1952
Reprint with Revisions, December 1952
Reprint with Revisions, February 1955

TABLE OF CONTENTS

FOREWORD	5
----------------	---

PART I

THE AIRCRAFT POWERPLANT

THE AIRCRAFT POWERPLANT.....	7
THE POWER SECTION.....	8
INSTRUMENTS AND CONTROLS.....	10
THE ACCESSORY REAR SECTION, THE NOSE SECTION, AND THE PROPELLER.....	11
THE LUBRICATION SYSTEM	15
THE COOLING SYSTEM	19
THE INDUCTION SYSTEM.....	25
1. Carburetion	25
2. Supercharging	33
3. Ducting	42
THE IGNITION SYSTEM.....	45

PART II

POWER, BMEP AND RATINGS

POWER AND ITS MEASUREMENT.....	47
BMEP	55
RATINGS	60

PART III

GENERAL OPERATING INSTRUCTIONS

STARTING	65
Control Position Check.....	70
Clearing The Engine.....	73
Priming	76
Starting	81

GROUND OPERATION	84
Warm-Up	84
Magneto Safety Check	86
Ground Check	87
Idle Mixture Setting	90
Taxiing	91
COLD WEATHER OPERATION	92
Preheating	92
Starting Cold Engines	94
Warm-Up	94
Flight Operation	95
Dilution	95
FLIGHT OPERATION	97
Take-Off	97
Transition From Take-Off To Climb	101
Flight — General	102
Power Selection	102
Bmep Selection	104
Altitude Selection	108
Induction System Icing	109
Climb	111
Transition From Climb To Level Flight	114
Level Flight	115
Descent	119
Glide and Approach	120
Landing	122
Stopping	122
Shutdown	122

PART IV

ADVANCED SUPERCHARGING

FOREWORD	124
PURPOSE OF SUPERCHARGING	124
RESULTS OF SUPERCHARGING	134
THE SINGLE-STAGE SUPERCHARGER	135
1. Ground Boosting	135
2. Low Altitude	136
3. High Altitude	137
Single-Stage, Two-Speed	138
Single-Stage, Variable-Speed	140
THE TWO-STAGE SUPERCHARGER	141
1. Two-Stage, Two-Speed	144
2. Two-Stage, Variable-Speed	145
3. Other Two-Stage Systems	146
APPENDIX	A1

FOREWORD

The aircraft engine is designed to power aircraft in flight. Its construction, installation, servicing, and repair present many interesting and important problems; but its actual operation is, naturally, of more immediate concern to the pilot. A number of texts, handbooks, and manuals are available which discuss the principles of engine design and installation, and describe the procedures of maintenance and overhaul. As a supplement to this material, it is the purpose of this book to discuss the powerplant as a functioning unit and an integral part of the aircraft in which it is installed, and so to provide a basis for an understanding of sound operating practice.

The first part of the book is devoted to a description of the basic engine sections and "systems" which together make up the powerplant, and discusses them in relation to the different instruments and controls by means of which the pilot regulates the performance of his engine. The second part deals with the fundamental concepts of power and its measurement, bmep, and ratings, with particular reference to the principles of engine operation. The last part of the book consists of a set of general operating instructions in which the material treated in the first two parts is applied to the specific problems of engine operation encountered in flight and on the ground. It is assumed that the reader is generally familiar with the main features of conventional engine design, with the names and functions of the more important units of the powerplant, and with the principles of the four-stroke cycle.

Many of the numerical values quoted are for the purposes of illustration and may not apply to all engines. Various temperatures are usually given in both Fahrenheit and Centigrade. For easy remembrance most of the temperature values are rounded out, rather than being exact equivalents, except those limits dictated by specification requirements. For specific values for any particular engine consult the applicable Specific Operating Instructions for the engine in question.

The material in the book and its supplements relates principally to the radial, air-cooled engines manufactured by Pratt & Whitney Aircraft, and is based on the experience of more than a quarter of a century in operating these engines.

PART I

THE AIRCRAFT POWERPLANT

OPERATION

The aircraft engine and the automobile engine are fundamentally alike in principle and design. Both convert the chemical energy of a mixture of fuel and air into useful work by the same process of internal combustion. Both incorporate the same basic mechanisms. Both furnish the motive power for the vehicles in which they are installed.

The operation of the aircraft engine, however, differs in many ways from that of the automobile engine. The performance required of the latter is relatively limited, and weight may be generously used to insure wide margins of safety. Even the uninformed driver can do little to abuse his engine, and to this extent the automobile powerplant has been "foolproofed." By contrast, a wide range of performance is demanded of the aircraft engine, while the weight of the powerplant must necessarily be kept to a minimum in the interests of over-all efficiency of the airplane. Accordingly, the operator must substitute his understanding and judgment for mere weight and solidity of structure, and, in place of "foolproofing" the engine, the operator must be "foolproofed" instead.

Engine ratings, or the restrictions placed on engine operation, are of little practical interest to the automobile driver, since in the course of ordinary driving he cannot easily exceed these limits. On the other hand, engine ratings must be one of the first concerns of the airplane pilot. It is possible to operate virtually any aircraft engine at excessive powers, and in most instances there is nothing to restrain the operator from exceeding the limits set by the ratings except his understanding and judgment. If the pilot makes use of engine speeds and cylinder pressures that are above the rated limits, he is relying upon margins of safety which may be dangerously narrow. If he fails to observe cylinder head or oil temperature limits, or operates

without regard to oil and fuel pressures or to fuel-air ratio, he is creating a situation that can only lead to lowered reliability and possible engine failure.

In operating an aircraft engine the pilot is confronted with the basic problem of combining engine speed and cylinder pressure in order to obtain power. The manner in which these two factors are combined, together with the maintenance of suitable conditions of cooling, lubrication, and mixture strength, determines the efficiency of the performance and the dependability and durability of the power plant.

DESIGN

Familiarity with the engine is basic to the understanding of sound operating practice. From an operator's point of view, a typical aircraft power plant may be considered as consisting of:

1. A Power Section
2. An Accessory Rear Section and a Nose Section, together with the Propeller
3. A Lubricating System
4. A Cooling System
5. An Induction System comprising Carburetion and Supercharging Systems
6. An Ignition System

A set of cockpit instruments, supplemented by the observed behavior of powerplant and airplane, enable the operator to determine the manner in which the different parts of his engine are functioning. A corresponding series of controls permits him to regulate their functioning. Efficient operation calls for the intelligent coordination of the several functions of the various sections and systems of the powerplant to meet changing conditions as they are encountered, having in mind the type of performance desired, and with due regard for the safety and protection of the engine.

THE POWER SECTION

PARTS AND FUNCTIONS

As the name implies, the power section is the section of the engine in which the power is developed, and which is the first to receive the impact of the loads created. It consists basically of the following assemblies:

1. The Cylinders

The aircraft engine is a heat engine which derives its power from the burning of a combustible mixture of gasoline and air. The fuel-air charge is ignited by a spark, and the heat generated by the burning of the charge expands the gases formed during its combustion.

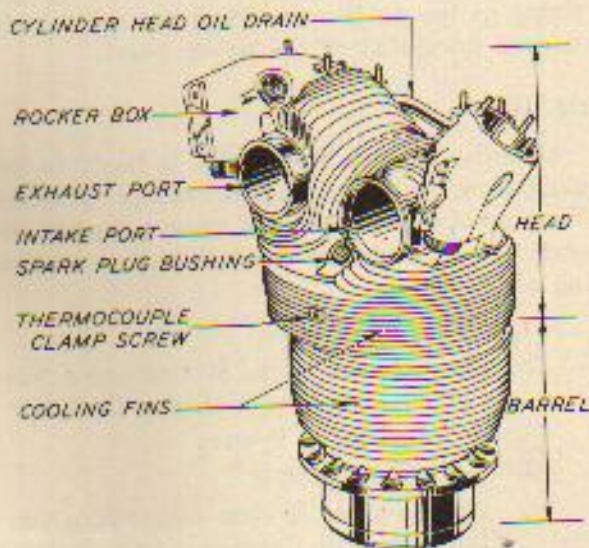

The chemical energy of the fuel and air is thus transformed into the mechanical energy of the expanding gases. Together with the pistons, the cylinders form the chamber in which the power-producing combustion takes place, and it is in them that the greatest concentration of heat and pressure is found.

2. The Valves and the Valve-Operating Mechanism

The valves control the admission of the fuel-air charge to the cylinders during the intake

stroke; imprison it during the compression and power strokes; and release the burnt gases during the exhaust stroke. The valve-operating

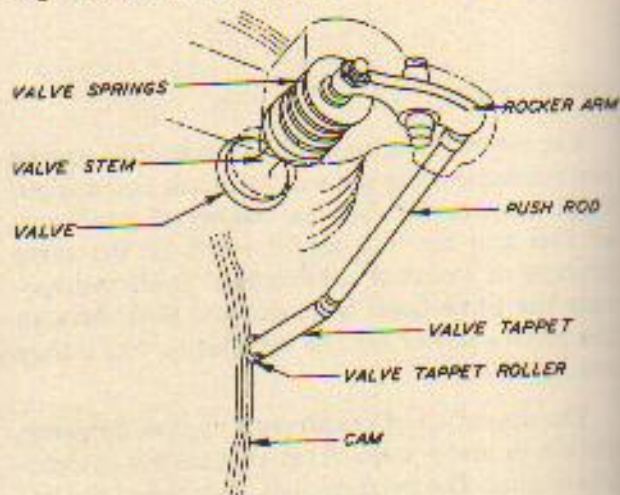

mechanism consists of a set of cams and a series of tappets, push rods, and rocker arms actuated by the cams to open and close each valve at the proper moment in the power cycle.

3. The Pistons

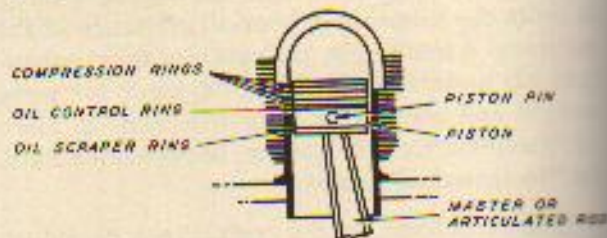

The pistons receive the force of the expanding gases and transfer it to the articulated and master rods. Like the cylinders, the pistons are subject to the heat and pressure of combustion, as well as to reciprocating forces.

4. The Master and Articulated Rod Assemblies

The master rod and articulated rods transfer the reciprocating motion of the pistons to the crankshaft where it is transformed into rotary motion. At the piston ends the rods are subject to reciprocating forces and to pressure loads resulting from combustion, while at the crankshaft centrifugal loads are also imposed on the

assembly as a consequence of the high rotational speed of the engine. There is one master

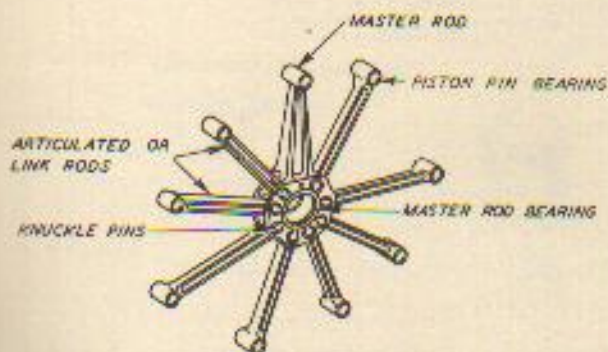

and articulated rod assembly and one crank throw for each row of cylinders.

5. The Crankshaft

The crankshaft receives the power developed in the cylinders from the master and articulated rod assembly, and transfers it through gear

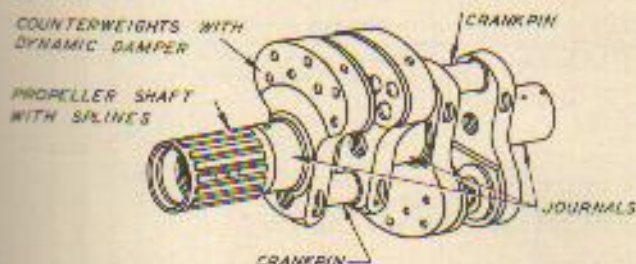

trains to the propeller, the supercharger, the valve-operating mechanism, the oil and fuel pumps, the magnetos, the propeller governor, the generator and other accessories. It is subject to a combination of centrifugal, reciprocating, and pressure loads, together with torsional stresses.

6. The Crankcase

The crankcase, generally in two or more parts, houses and supports the crankshaft, and to it are attached the cylinders and the nose and supercharger housing sections. Its bearings absorb the power-producing loads from the pistons and crankshaft.

POWER SECTION CONTROL

While conditions in the power section are ultimately the chief concern of the operator, the control of this section is not direct, and only one instrument, the cylinder head temperature gage, is actually connected to it. Instead, control is exercised through other parts of the powerplant, and the effects of this regulation are measured indirectly by various instruments which indicate conditions obtained in the nose and rear sections and in the lubricating, cooling, induction, and ignition systems. For example, cylinder pressures are controlled by the throttle of the induction system and by the propeller speed governor on the nose section; and these pressures are measured in terms of the readings of the manifold pressure and carburetor air temperature gages of the induction system (or the torquemeter gage from the nose section) and the tachometer connected to the rear section.

An understanding of proper engine operation accordingly requires:

1. A familiarity with the various cockpit instruments and controls — their names and their location.
2. An appreciation of the meaning of the reading of each instrument—the condition it indicates at the particular part of the powerplant to which it is connected, and the significance of this condition as it affects the power section and other parts of the engine.
3. A knowledge of the function of each control — the particular part of the powerplant which it controls, and the effect of this regulation on conditions in the power section and elsewhere through the engine.

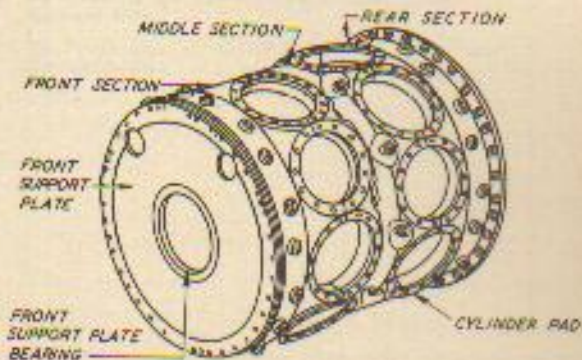

PRESSURE

CONTROL — Throttle Lever

Opening and Closing Throttle

IMPELLER SPEED

Varying impeller speed by means of crankshaft cam. On some engines the impeller speed may be further controlled by selection of impeller drive ratio.

INDICATION — Manifold Pressure

PRESSURE AFFECTS:

1. Power
2. Loads On

Cylinder head down studs

Master and list rods

Master rod bearings

And remaining power transmission parts from the crankshaft to the propeller shaft.

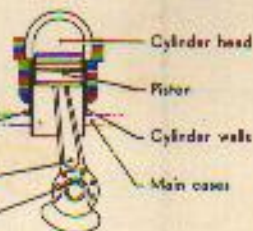

Normal Combustion
Controlled and even applied pressure



Detonation
Sudden and uncontrolled pressure

As friction and related wear are affected by the loads forcing adjacent surfaces together, the durability of the power producing and the power transmission systems are affected by the pressures used to produce power.

CHARGE TEMPERATURE

CONTROL — Lever in cockpit admitting air into carburetor from heated source.

INDICATION — Carburetor air temperature gage

CARBURETOR AIR TEMPERATURE AFFECTS:

1. Power
The power available from the combustion charge varies with the charge density which is affected by the temperature of the charge.
2. Tendency to Detonate
As the heat rise of the supercharger is added to the temperature of incoming charge, excessive carburetor air temperature can result in raising the charge temperature to the critical point causing detonation.



CARBURETOR AIR TEMPERATURE

MIXTURE STRENGTH

CONTROL — Mixture lever

INDICATION — On some installations; fuel-air analyzer or fuel flowmeter

MIXTURE AFFECTS:

1. Power
To produce power fuel-air ratio must be controlled within a narrow range.
2. Tendency to Detonate
Operation with mixtures too lean for the power used results in detonation.
3. Fuel Economy
To realize the most miles per gallon of fuel, precise mixture control must be exercised.



MIXTURE STRENGTH



MANIFOLD PRESSURE



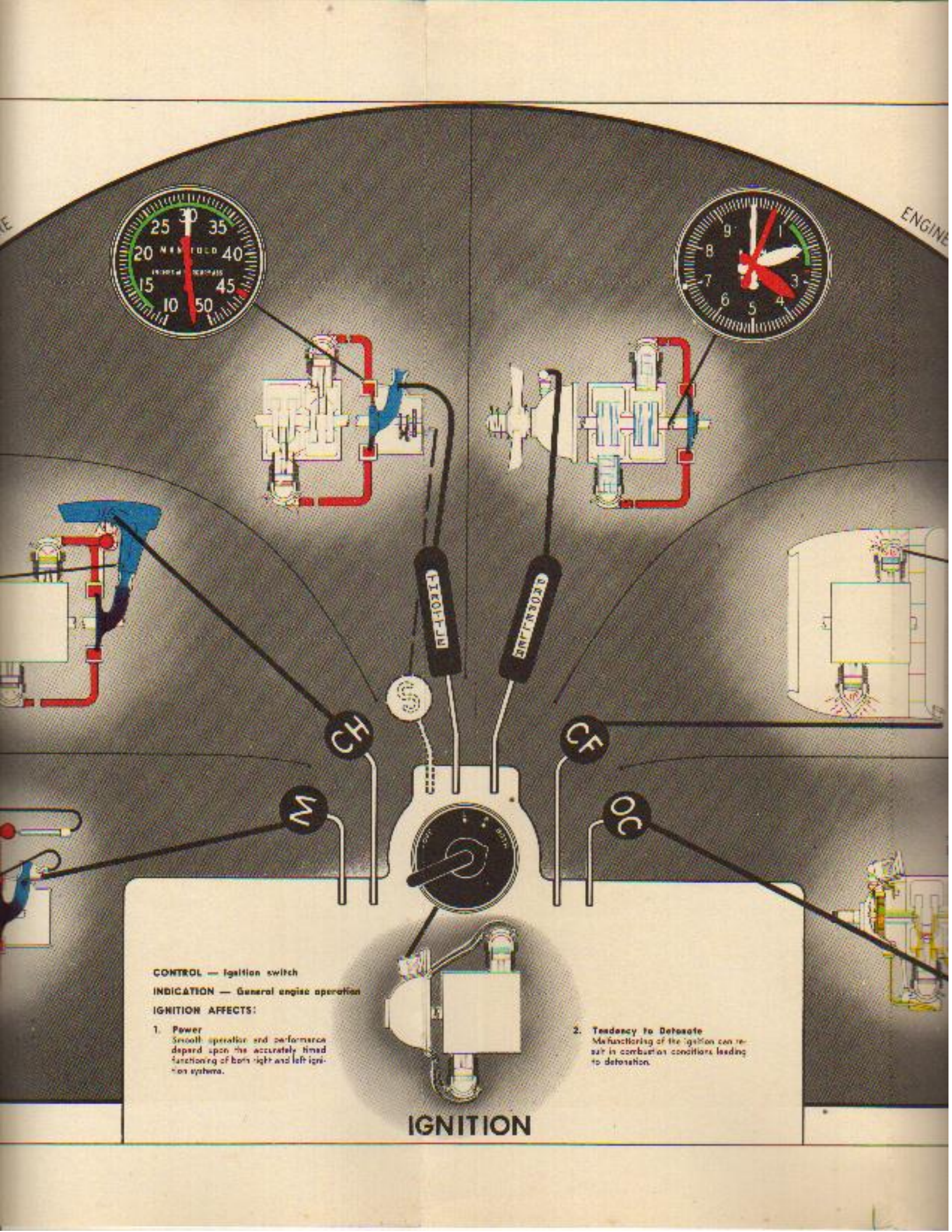

CONTROL — Ignition switch

INDICATION — General engine operation

IGNITION AFFECTS:

1. **Power**
Smooth operation and performance depend upon the accurately timed functioning of both right and left ignition systems.

2. **Tendency To Detonate**
Malfunctioning of the ignition can result in combustion conditions leading to detonation.

IGNITION

SPEED

CONTROL — Propeller control lever if controllable propeller used

INDICATION — Tachometer

SPEED AFFECTS:

1. Power
2. Rubbing and Rolling Speeds

ENGINE SPEED - R.P.M.



Between piston rings and cylinder walls



Between shafts and bearings



Between the teeth of gears



Between balls or rollers and races of anti-friction bearings

3. Reciprocating Loads

The mass of the pistons and the articulated and master rods must be accelerated from zero to a high velocity and then be decelerated to zero in the course of one stroke. These accelerations and decelerations produce loads on these parts which are passed on to the engine structure through the crankshaft. Reciprocating loads increase the friction produced by rubbing and rolling.

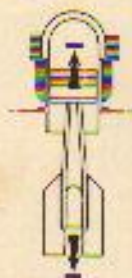

4. Centrifugal Loads

Imposed by the speed of rotation on the crankshaft, the articulated and master rods and the master rod bearings. Loads vary as the square of the rpm. Doubling the rpm multiplies the load by four. Tripling the rpm multiplies the load by nine.



5. Tendency to Detonate

The heat rise through the supercharger has the same effect on the mixture charge as application of carburetor heat. The temperature of the charge as it enters the cylinder is the most critical factor leading to detonation. The heat rise varies with rpm.

CYLINDER TEMPERATURE

CONTROL — Airflow over cylinders can be varied by
a) Airspeed
b) Position of cowl flaps on some installations.

INDICATION — Cylinder head temperature gage

CYLINDER TEMPERATURE AFFECTS:

1. The Material Strength of the Cylinder and Piston Rings
2. The Condition of Valves, Cylinder Walls and Piston Rings
3. Tendency to Detonate
An overheated cylinder can raise the temperature of the mixture to the detonation point.



LUBRICATION

CONTROL — Usually automatic.
On some installations cockpit lever controls position of oil cooler shutters or oil.

INDICATION — Oil temperature gage
Oil pressure gage

LUBRICATION AFFECTS:

1. The Condition and Rate of Wear of Every Surface That Rubs and Rolls.
2. The Temperature of the Pistons, Cylinder Skirts, Bearings and Gears.

THE ACCESSORY REAR SECTION, THE NOSE SECTION,
AND THE PROPELLER

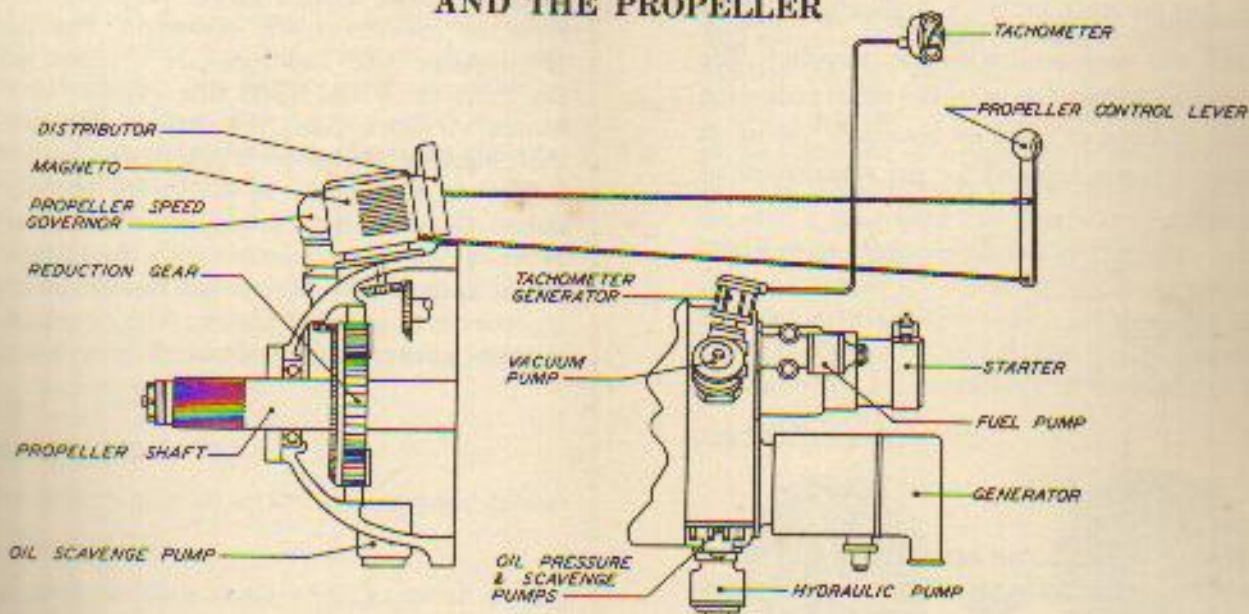

THE ACCESSORY REAR SECTION

Crankshaft power is transmitted by means of an accessory drive shaft through the supercharger housing to the accessory rear section, where a series of gear trains, in turn, transmit the power to drive the oil pressure and scavenge pumps, the magnetos (if rear-mounted), and various engine-driven accessories, including the

fuel pump, the vacuum and hydraulic pumps, the generator, the tachometers, and the gun synchronizer. The accessory rear section houses the oil pressure and scavenge pumps; provides mounting pads for the magnetos and the engine-driven accessories; and furnishes connections for the starter, the auxiliary power drives, and the oil lines.

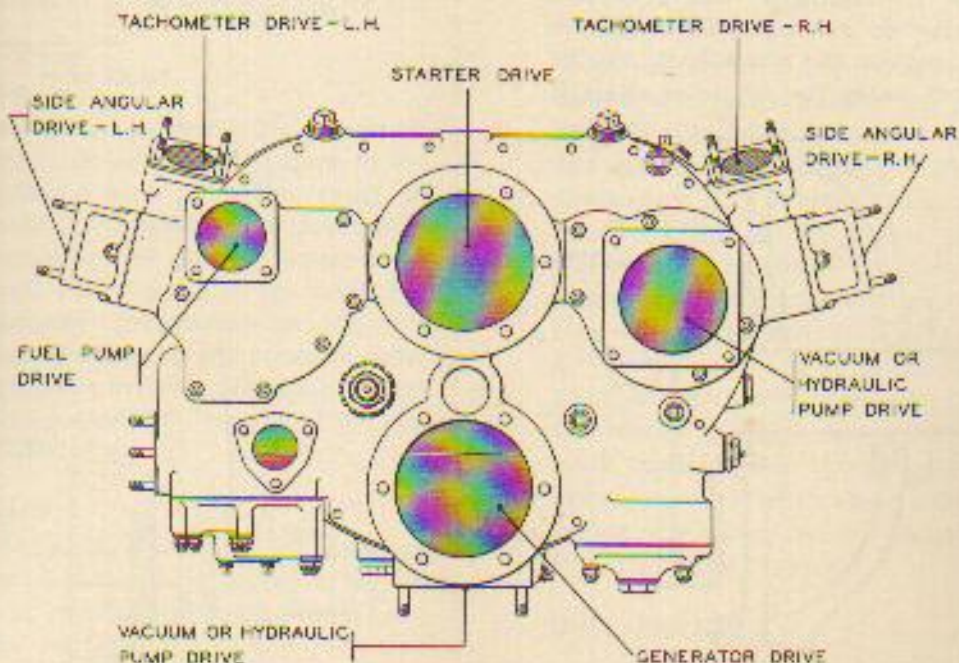

Accessory locations are typical and do not apply to all engines.

THE NOSE SECTION

Crankshaft power is transmitted forward through the nose section to the propeller. The nose section houses the propeller shaft reduction gearing and one or more oil scavenge pumps. It provides a power take-off for the attachment of

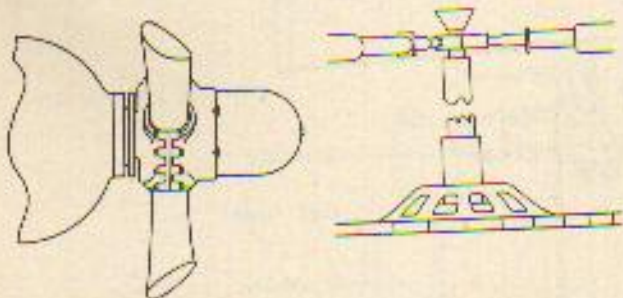

a propeller or helicopter rotor drive; and it furnishes mounting pads and drives for the scavenge pumps, the nose-mounted magnetos and distributors, the propeller governor, and other accessories.

REDUCTION GEARING — DRIVE RATIOS

1. Direct Drive

Small engines which operate at relatively low rpm and which are equipped with propellers of small diameter do not normally require a reduction gear between the crankshaft and the propeller. In such cases the propeller shaft is

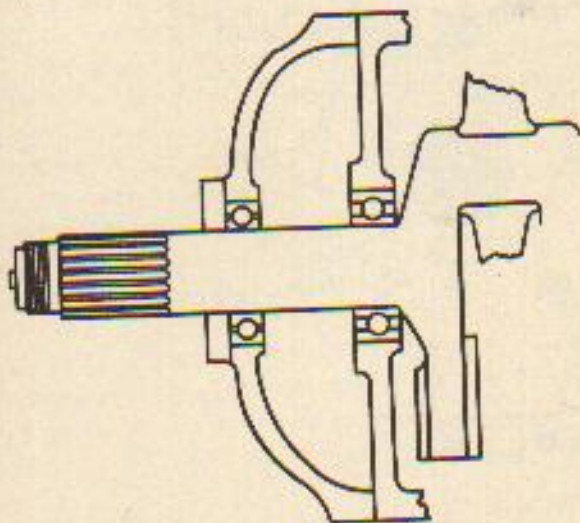

an extension of the crankshaft, and the propeller is directly driven at engine speed.

2. Geared Drive

Larger engines require bigger propellers to absorb the greater power developed. The limits of propeller size and rpm are reached when the velocity of the blade tips exceeds that of sound, at which point the thrust efficiency of the propeller begins to break down, while the energy of the engine is dissipated in making noise. By placing a speed reduction gearing between the crankshaft and the propeller shaft, both engine and propeller can be made to operate at efficient speeds. The range of reduction gear ratios is from 4:3 to 3:1.

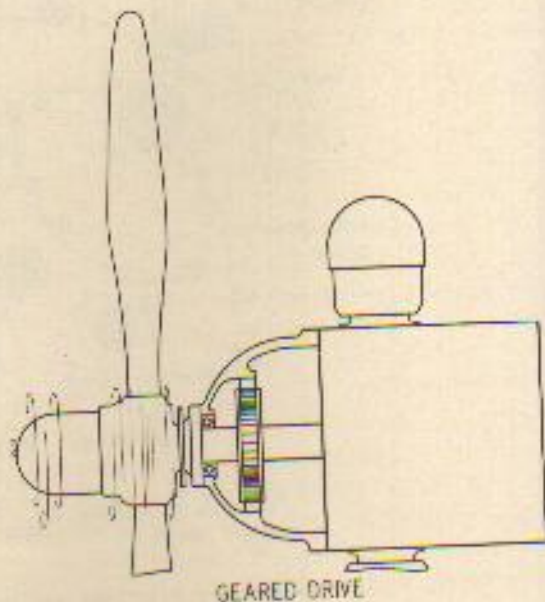
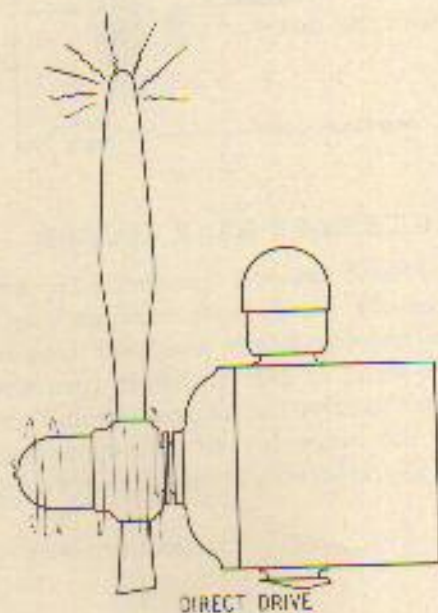

THE PROPELLER

The propeller is essentially a device for converting shaft horsepower into thrust horsepower. It is quite possible, however, for a propeller to absorb the entire power output of an engine and deliver little or no useful work in return. If it is to function efficiently the propeller must be:

1. Correctly designed for its particular installation — size, shape, number and pitch of blades, and freedom from excessive vibration.
2. Operated within the proper speed range for its design.

PROPELLER TYPES

Propellers may be divided into general types:

1. Fixed Pitch

The pitch, or blade angle, of this type of propeller is fixed and cannot be varied in flight. (In some models the pitch is adjustable on the ground.) This installation is light and simple, and gives satisfactory performance within a limited range of power and speed. The power absorbed by this type of propeller varies as the cube of the rpm — i.e., $bhp = K \times rpm^3$. Accordingly, for any given power there is a corresponding rpm. Since power can be regulated by manifold pressure only with this type of installation, propeller speed is controlled by the throttle.

2. Two Position

A hydraulic mechanism, operated by engine oil pressure, makes it possible for the pilot to select in flight either a high pitch (low rpm) or a low pitch (high rpm) position for more efficient speed regulation. A desired power may thus be obtained with two different combinations of rpm and manifold pressure: a high rpm and low manifold pressure or the opposite combination in high pitch. In both positions engine power and, hence, speed are regulated by the throttle, as with a fixed pitch propeller.

3. Variable Pitch

A hydraulic, electrical, or mechanical mechanism permits the pilot to set the propeller blades while in flight to any desired angle over a considerable range. As the pitch of the propeller is increased the resistance offered to it by the air becomes greater, and if other factors, such

as manifold pressure, remain unchanged, the rpm will decrease. Conversely, a decrease in pitch will result in a higher rpm. Engine power and speed, accordingly, no longer bear any fixed relation to one another.

The constant speed propeller is a variable pitch propeller in which the regulation of the pitch is automatically controlled by a governor in such a way that the rpm is maintained unchanged at a figure selected by the pilot, regardless of changes in power or manifold pressure. Such an arrangement offers the greatest possible flexibility of operation, but it places upon the operator the responsibility of choosing a well-

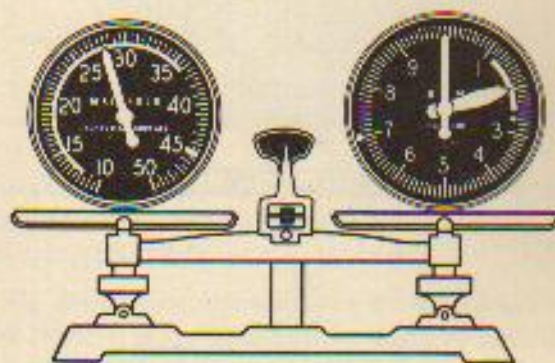

balanced combination of rpm and manifold pressure to obtain a desired power and, at the same time, make the most efficient use of both engine and propeller.

An extension of the variable pitch principle makes it possible to set the propeller blades roughly parallel to the line of flight, and so stop the engine while in the air. This is known as **feathering**, and is often found useful in emergencies which involve engine failure. With the blades in the feathered position, the drag of the propeller is reduced, while the possibility of further damage to aircraft and powerplant from a "windmilling" engine is prevented. It is also possible with some types of propellers to turn the blades past full low pitch into a reversed pitch position, thus reversing the thrust of the propeller — a feature which is helpful in maneuvering a seaplane on the water or braking an aircraft on the ground.

RPM CONTROL

Engine speed, or rpm, is thus controlled in one of the following ways:

1. By the throttle lever, in the case of fixed pitch propellers (or the high or low pitch position of a two-position propeller); or,
2. By the propeller governor control lever, in the case of variable pitch propellers.

Constant speed propeller installations commonly include a governor driven by a gear train from the crankshaft and mounted on the nose section. By directing engine oil under high pressure to the mechanism contained in the propeller

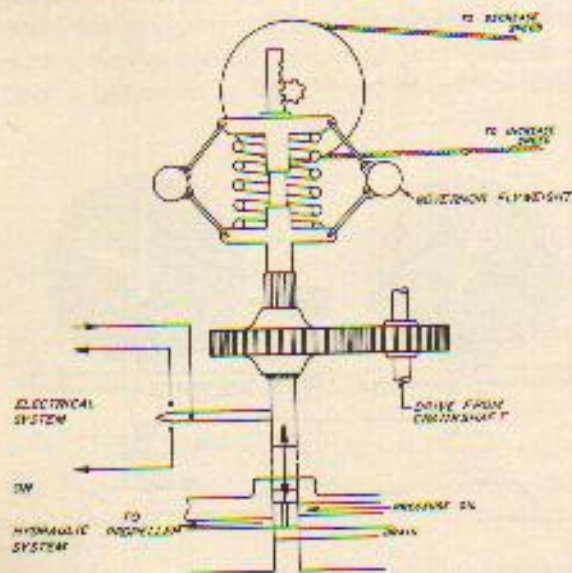

hub, or by controlling the electrical impulses sent to a hub-enclosed motor, the governor regulates the pitch of the propeller blades in such a way as to maintain a constant rpm regardless of power, manifold pressure, or altitude. On other installations the propeller itself includes the governor as an integral part of the hub, and the complete control system, including the oil supply, is independent of the engine.

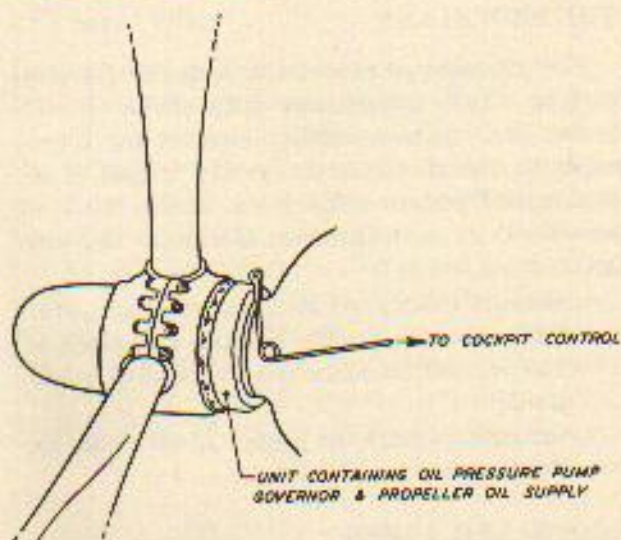

It should be noted that, if the governor is set to regulate at a high or at maximum rpm, and the engine is not developing sufficient power to turn the propeller at this speed, the latter will be driven in full low pitch in the same manner as if it were a fixed pitch propeller. In other words, propeller speed is a function of manifold pressure, and is controlled by the throttle until the governing rpm is attained. This characteristic is made use of in pre-flight checks and other ground operations at low power.

Proper operation of hydraulic propellers demands that the oil be at the correct temperature and pressure. Oil that is too cold to flow freely will result in a sluggish response of the propeller to the governor. In the case of electric propellers, proper operation requires that the electric power reserve be capable of delivering a current sufficient to actuate the pitch control mechanism. Operation with weak batteries drained by other demands can lead to serious over-speeding.

THE LUBRICATING SYSTEM

Oil is often referred to as the "lifblood of the engine," and by analogy the lubricating system may be somewhat crudely compared with the human circulatory system. Oil is forced from the pressure section of the oil pump (right side of heart) through various pipes and passages (arteries) to different parts of the engine (capillaries). After performing its lubricating and cooling functions, the oil is collected in one or more sumps where it is drawn through other passages and pipes (veins) by one of the several scavenge pumps (left side of heart), and sent thence through the oil cooler (lungs—the analogy is a trifle strained) to the tank, and so back once more to the pressure pump.

The principal features of a typical lubricating system are shown, and their functions briefly explained, in Fig. 1 on page 16.

FUNCTION

The lubricating system of an aircraft engine performs three functions:

1. It reduces friction between sliding and rolling surfaces.

To the naked eye a highly finished metal surface appears like this:



But under a microscope a cross-section would look more like this:

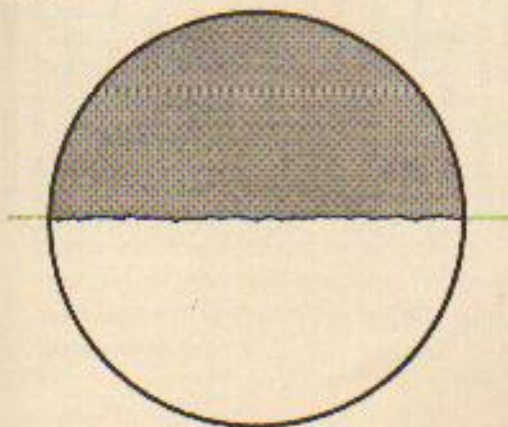

If two such surfaces were to slide over one another in direct contact, the result would be an

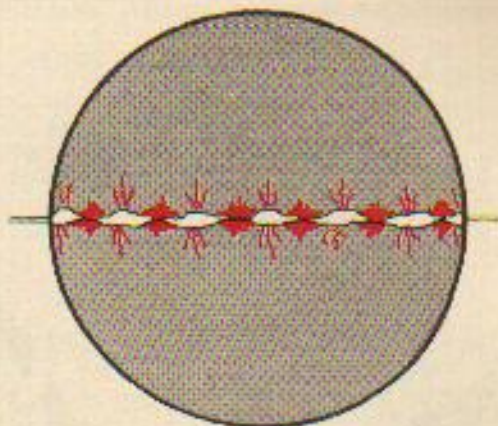

interference between the surface peaks, which would lead to excessive friction and end by destroying the surfaces.

By separating the surfaces with a film of oil the friction is reduced to that existing between the molecules of the lubricant. The oil in direct

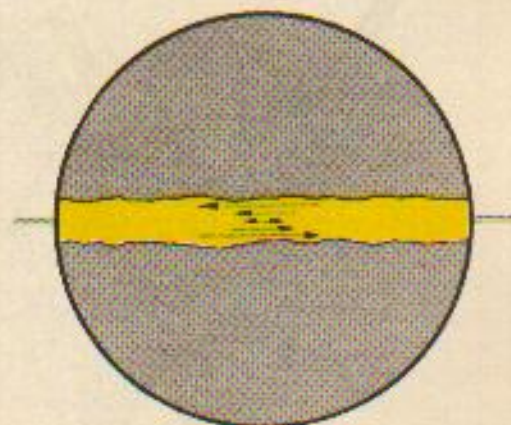

contact with the surfaces moves with the surfaces; friction then occurs only by reason of the intermediate oil layers sliding over one another.

With perfect lubrication no wear of the bearing surfaces should occur except, possibly, at starting, for at all other times they are separated by an oil film. When properly designed and lubricated, plain bearings may have a coefficient of friction as low and a load carrying capacity as high as ball or roller bearings.

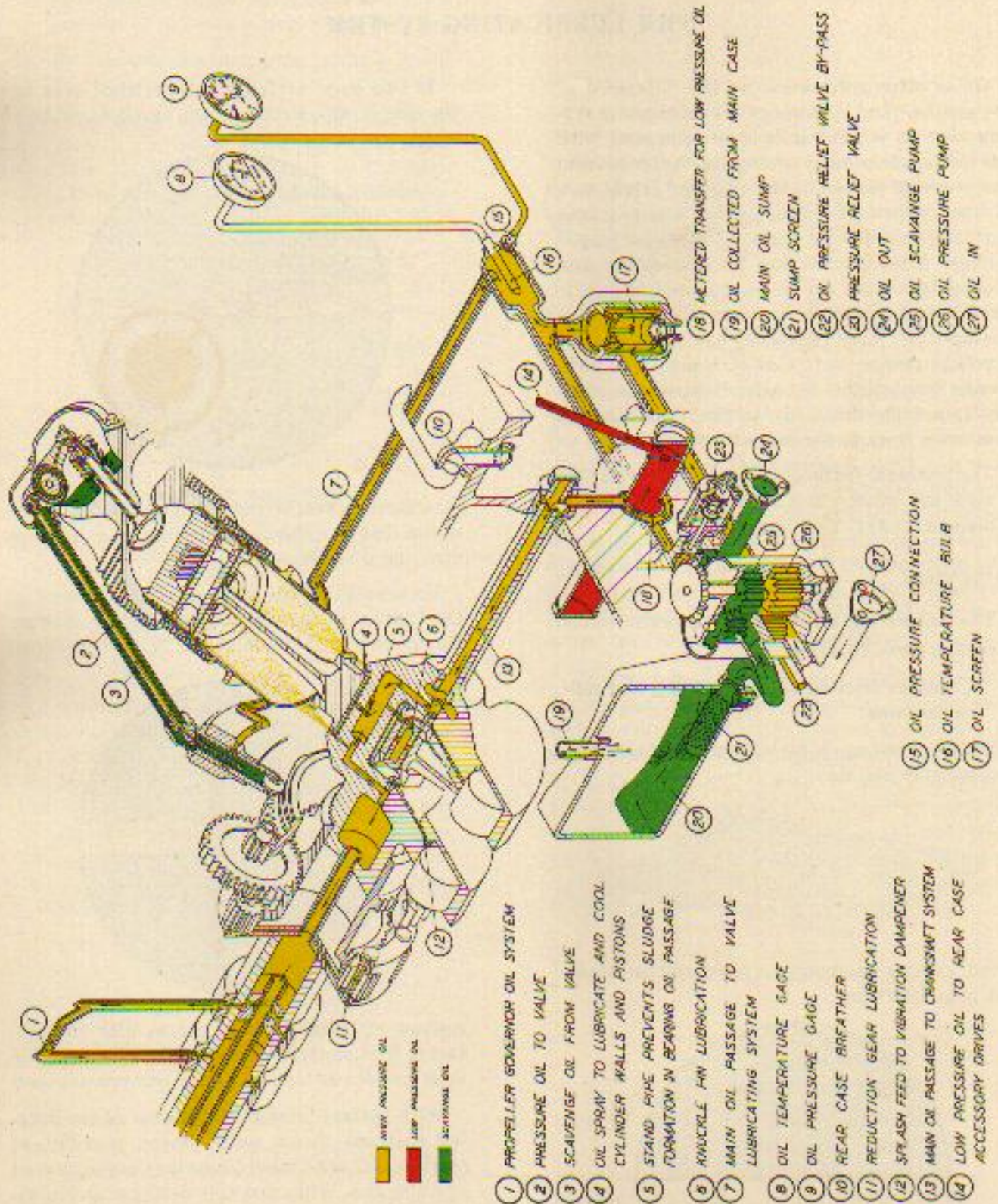
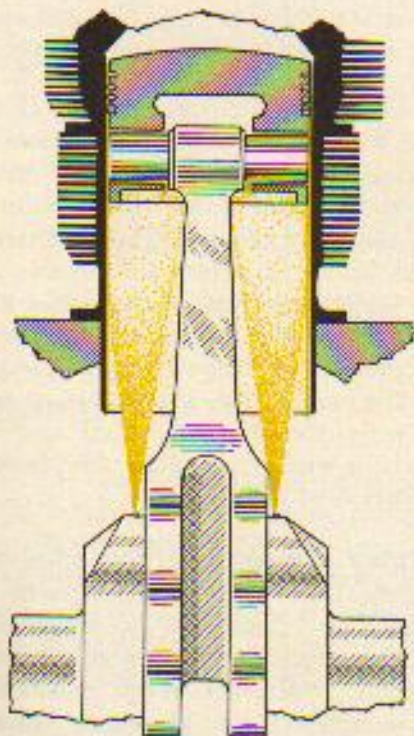

Fig. 1 - A Typical Engine Oil Circulating System

2. The lubricating system cools parts of the engine that cannot be cooled by air.

For example: the piston, which forms one end of the combustion chamber, is subject to the most intense heat present in the engine. To cool it a spray of oil is directed to the under side of the piston through jets located in the crankshaft. This spray also lubricates the cylinder walls and piston pins, and assists in cooling the



lower parts of the cylinder wall. The master rod bearing is another example of a part that is both cooled and lubricated by the oil of the system. Approximately 10% of the heat released by combustion is removed from the engine through the lubricating system.

3. The lubricating system furnishes oil for the operation of various units and accessories, such as:

- a. The blade angle varying mechanism of the hydraulically-operated propeller. (In this instance engine oil pressure is boosted by the propeller governor or by the feathering pump.)
- b. The impeller drive clutches, variable spark advance mechanism, manifold pressure regulator, and other units. (Units such as these are operated by normal engine oil pressure.)

CONTROL OF OIL PRESSURE, TEMPERATURE, AND FLOW

To perform its several functions satisfactorily, lubricating oil must be:

1. **Within the proper pressure limits.** If oil pressure is too low, oil may not reach all parts of the engine, will not be forced in between bear-

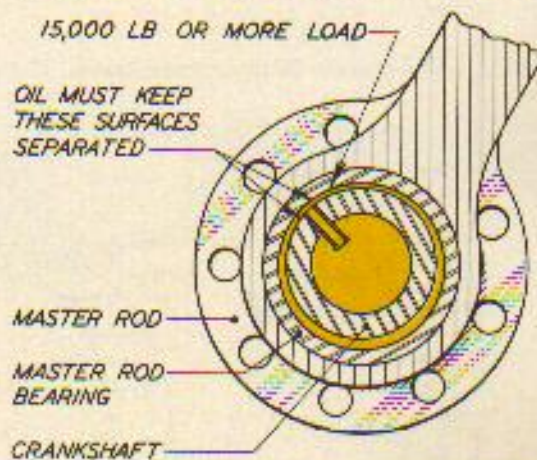

ing surfaces, or provide adequate flow and spray for cooling.

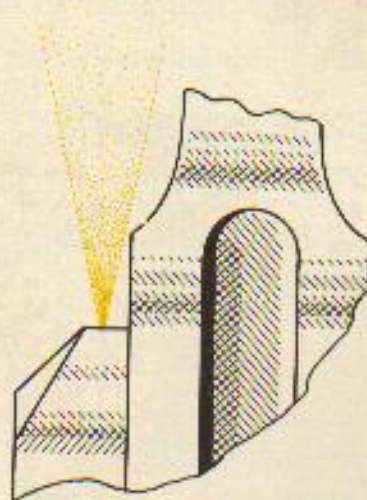

If oil pressure is too high, oil leaks are likely to develop and oil consumption to become excessive.

Of the various cockpit gages, none is more important than the oil pressure gage. **Loss of oil pressure is an indication of the failure of the oil supply,** and without lubrication it may be only a matter of seconds before parts have heated and burned, bearings have seized, and the engine is brought to an abrupt halt, badly damaged.

This emphasizes the vital importance of making the proper oil pressure checks prior to take-off. An oil pressure relief valve fixes an upper limit to engine oil pressure once the engine has been warmed up. (Because of the viscosity of cold oil, pressures of several hundred psi may be encountered when starting.) The relief valve must be set on the ground, and cannot be adjusted in flight.

2. Within the proper temperature limits. If the

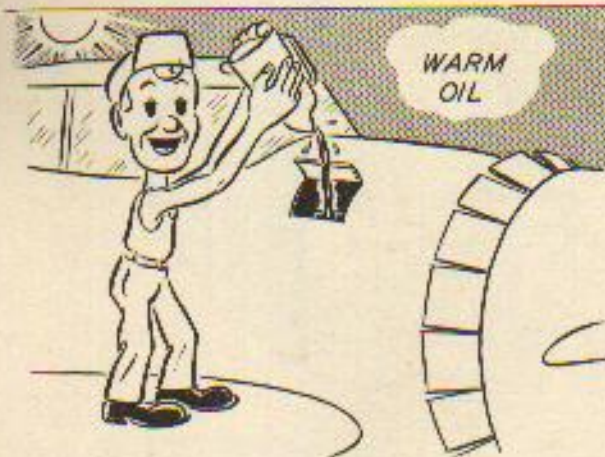

oil is too cold, it will not flow freely.

If the oil is too hot, it cannot support heavy bearing loads, it cannot carry away enough heat, and it may result in too great an oil flow. As a consequence, oil pressure may drop below acceptable limits, and oil consumption becomes excessive.

In performing its lubricating and cooling functions the oil absorbs a considerable amount of heat—the equivalent of 30 horsepower or more in the larger engines. With very small engines this heat can be dissipated through the engine cases and the surfaces of the oil tank; on larger engines an external oil cooler is necessary. The oil cooler is equipped with shutters or flaps by means of which the flow of cooling air can be regulated to obtain the desired oil temperatures. The oil cooler shutters are controlled automatically or manually by means of a cockpit lever.

It is the practice to measure the oil temperature at a point in the engine lubrication system that is close to the oil inlet. By taking the temperature at this point, the oil temperature reading is then a check of the condition of the lubricant before it enters the engine. Measuring the oil temperature at the outlet has been seriously considered but, as the temperature at this point is a measure of the oil temperature rise in the engine, the gage reading will vary widely with changing conditions and will not constitute a stable standard for determining the condition of the oil.

If, during a climb with wide open shutters, the airflow does not provide sufficient cooling, a greater flow of air may be obtained by reducing the angle of climb and so increasing the speed of the airplane. A final means of lowering oil temperature is to reduce power. This should be done by lowering the rpm as well as the manifold pressure, since friction and oil temperature are affected by engine speed even more than by power.

3. Of suitable quality and sufficient mechanical strength so that the oil film will not break down under any condition of temperature and pressure likely to be encountered.

CONTROL OF THE LUBRICATING SYSTEM

The operator has no control of the lubricating system while in flight other than to regulate the temperature of the oil in response to the readings of the inlet oil temperature gage. The vital importance of the lubricating system renders it imperative that all ground checks be scrupulously performed to make certain that all adjustments have been properly made.

THE COOLING SYSTEM

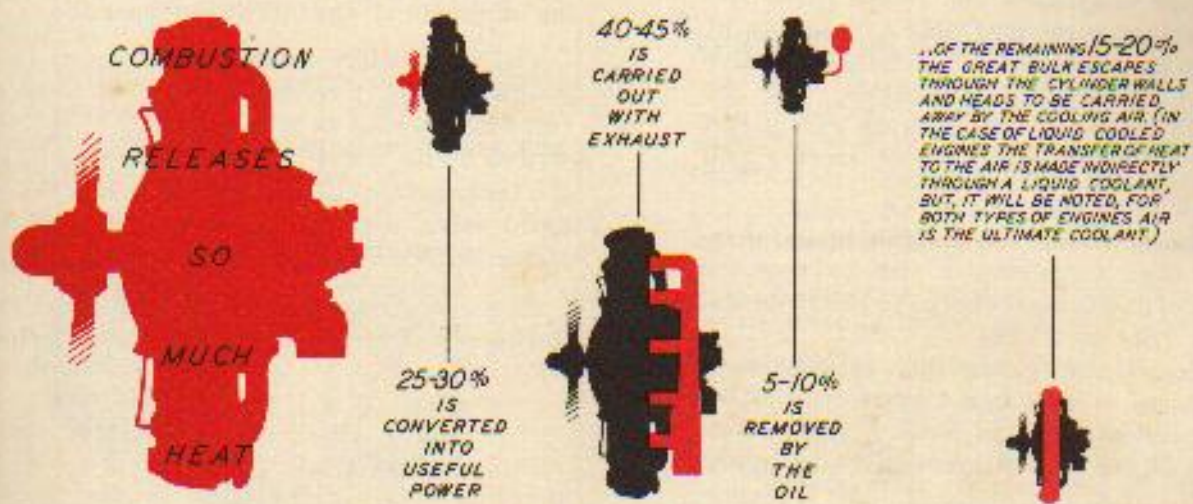

Fig. 2 - Heat Disposal

HEAT DISSIPATION

Of the total heat energy released by combustion only about one-quarter is converted into useful power. The balance of the heat must be dissipated in such a way that the resulting temperatures will not prove destructive to the engine. In a typical aircraft power plant heat dissipation is accomplished roughly as shown in Fig. 2.

Heat is thus dissipated through the exhaust system, the lubricating system (as discussed in the previous section), and the air cooling sys-

tem. It is with the last system that this section is concerned.

EFFECTS OF TEMPERATURE

High cylinder temperatures may lead to serious consequences:

1. **Weakening of the cylinder heads.** Cylinder heads are commonly made of an aluminum alloy. The strength of this material is closely related to its temperature, as shown in Fig. 3. If the indicated cylinder head temperatures are allowed to exceed the usual limits of 450-500 F

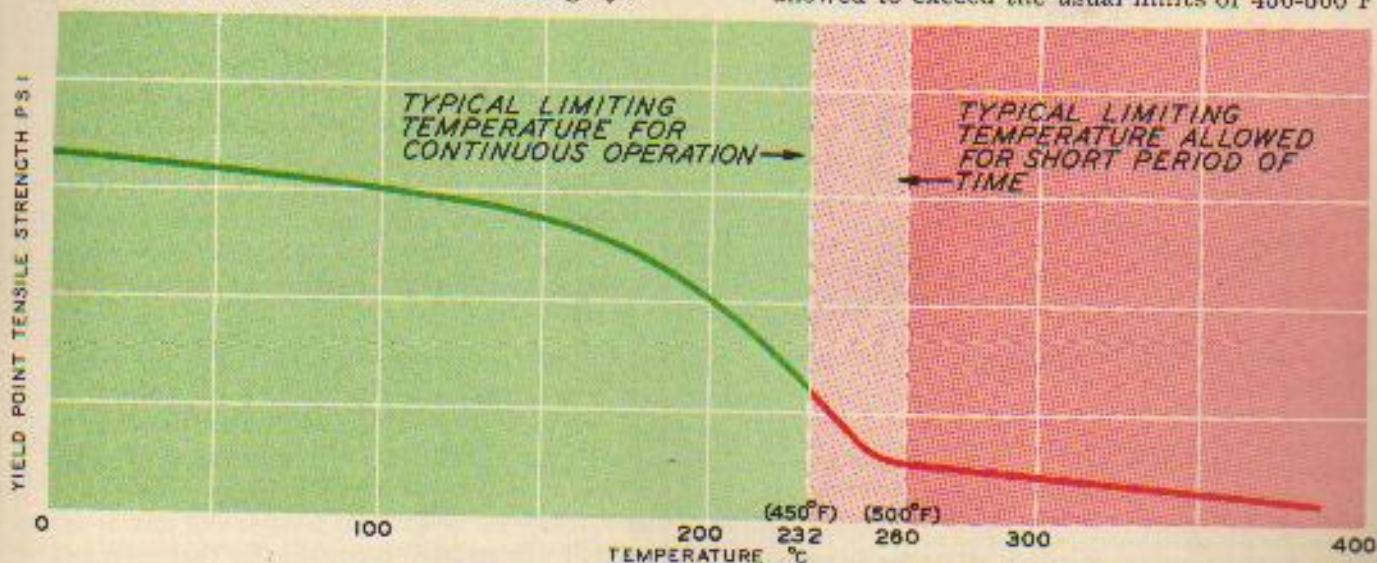

Fig. 3 - Strength of Aluminum Alloy vs Temperature

(232-260 C)³, the material will be seriously weakened.

2. **Damage to cylinder and piston parts.** Excessive temperatures may lead to warping of the valves and valve seats, and failure of valve stem and rocker arm lubrication, and the breakdown of the oil film between piston and cylinder, with the possibility of scoring and even seizure.

3. **Increased tendency to preignition and detonation.** High temperatures also increase the tendency of the fuel-air charge to preignite and detonate. (See pp 27-29)

Preignition in turn causes high cylinder head temperatures — and so a vicious cycle is begun. Regardless of which comes first, however, the effect on the engine is inevitably damaging.

TEMPERATURE INDICATION

Cylinder head temperatures are indicated by means of a gage connected to a thermocouple attached to the cylinder which experience shows to be the hottest on an engine in any particular installation. The thermocouple itself is located:

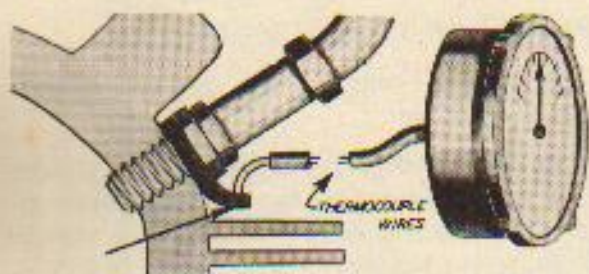

Under a rear spark plug in a special gasket.

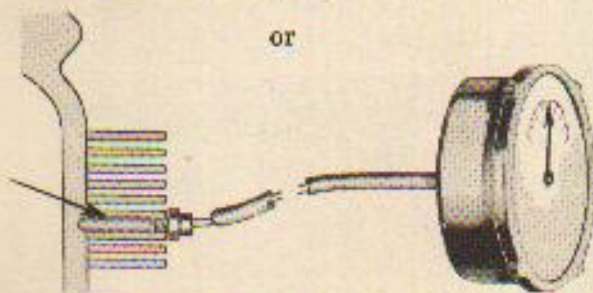

In a special well in the top or rear of the cylinder head.

³ The cylinder temperatures quoted above and in the remaining portions of this book are those which have applied to many engine models heretofore manufactured by Pratt & Whitney Aircraft. Limits applying to engines of other manufacture, or to some present or future Pratt & Whitney Aircraft models, may differ somewhat from the temperatures quoted above.

The thermocouple location is selected because of its stability as a temperature reference and because of the mechanical advantages for making a practical and durable connection.

The temperature recorded at either of these points is merely a reference or control temperature; but so long as it is kept within the prescribed limits, numerous tests have shown that the temperatures of the cylinder dome, the exhaust valve, with its seat and guide, and the piston will also be within a satisfactory range.

As a rough example, it can be imagined that the household thermostat has been placed above

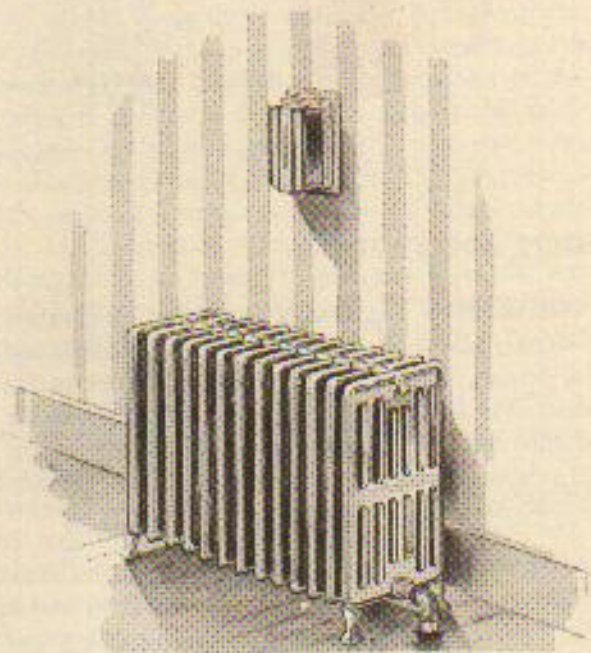

a radiator. In order to obtain the desired room temperature it will be necessary to set the thermostat (reference or control temperature) to some higher figure. The thermocouple is the cylinder's thermostat indicator. Its limit is established, arbitrarily, in order to keep at satisfactory temperatures the vital portions of the cylinder whose temperature cannot be measured directly.

As the thermocouple is attached to one cylinder only it can do no more than give evidence of general engine conditions. While normally it can be presumed that the remaining cylinder temperatures will be lower, local conditions such as detonation or ignition failure will not be indicated unless they occur on the thermocouple cylinder.

LIMITING TEMPERATURE

Two limiting cylinder head temperatures are usually found in specific engine operating instructions:

1. The higher limiting temperature is for a restricted period of time, and is confined to take-off, to maximum performance in climb and level flight, and to emergencies.



ABSOLUTE MAXIMUM FOR ONE HOUR ONLY

The temperature limit for restricted operations should, therefore, be used for the shortest possible time only, and must never be exceeded.

2. The lower limiting temperature is the maximum for continuous operation. It should never



be exceeded except under the restricted operating conditions mentioned in the previous paragraph. It is sound practice to hold the cylinder

head temperature 50 F (30 C) below this limit to keep the cylinder head materials at high operating strength.

THE COOLING SYSTEM

In all aircraft cooling systems air is used to carry the heat away from the cylinders. When this is done directly, without an intermediate liquid coolant, the problem of cooling largely resolves itself into that of:

1. Exposing a sufficient surface area of the cylinders to the cooling airflow.
2. Directing the air efficiently against all parts of the cylinders.
3. Providing a sufficient cooling airflow, together with some means of regulating the airflow in response to varying conditions.

The surface area of the cylinders exposed to the cooling airflow is increased by the use of cooling fins. The efficiency of the fins is increased, up to a certain point, as they are made deeper and spaced more closely together.

Not many years ago engine cooling was accomplished by simply holding the cylinders into the breeze. This arrangement had several shortcomings. While all the air in the path of the engine passed between the cylinders of the engine, only a small portion of it came close enough to the fins to remove much of the heat. The cylinders were cooled unevenly, the rear portions of each one tending to run hotter than the front. The turbulence created affected all parts of the airplane aft of the engine.

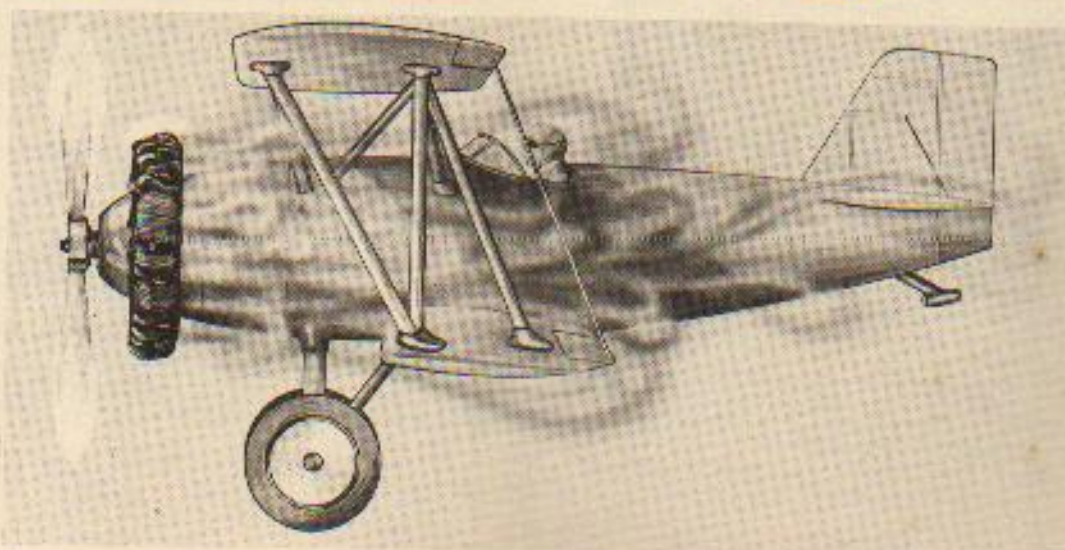

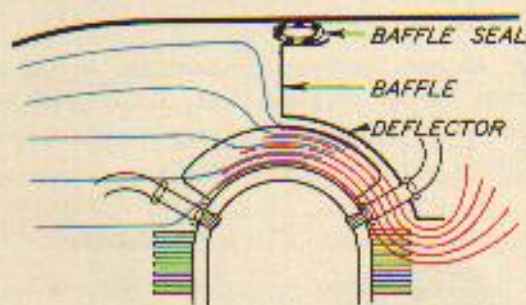
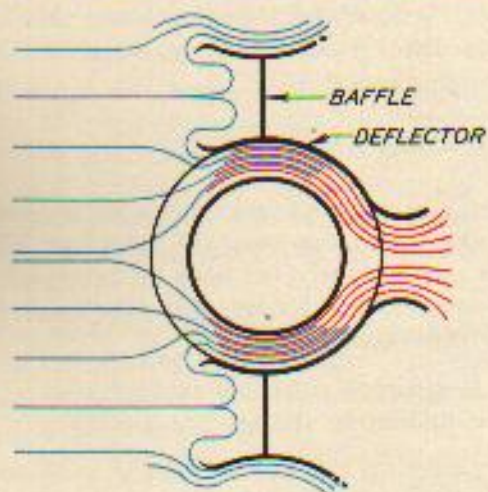

More recently inter-cylinder and cylinder head baffles have been used to force the cooling air into close contact with all parts of the cylinders. In this way the entire airflow is used to carry the heat away from the fins. Although the resistance offered by the baffles and fins to the passages of the cooling air demands that an appreciable pressure differential be maintained across the engine to obtain the necessary air-

flow, the volume of cooling air required is much reduced by the use of a properly designed system of deflectors, and the resulting drag is actually decreased. A flow of cooling air sufficient to carry away the heat from the cylinders is obtained by means of the cowl which encloses the engine. The flow of cooling air may be regulated by a series of adjustable cowl flaps at the rear of the cowl-

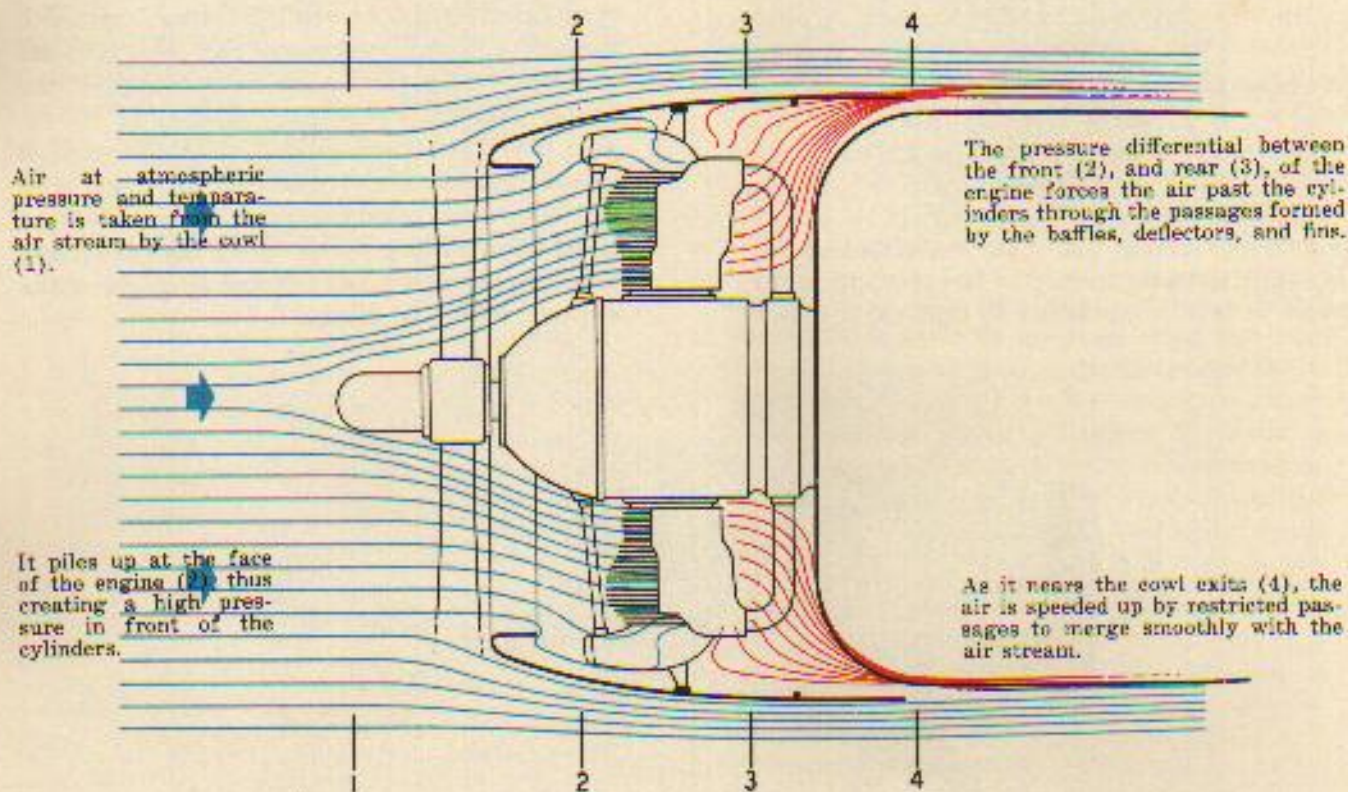

Air at atmospheric pressure and temperature is taken from the air stream by the cowl (1).

It piles up at the face of the engine (2) thus creating a high pressure in front of the cylinders.

The pressure differential between the front (2), and rear (3), of the engine forces the air past the cylinders through the passages formed by the baffles, deflectors, and fins.

As it nears the cowl exits (4), the air is speeded up by restricted passages to merge smoothly with the air stream.

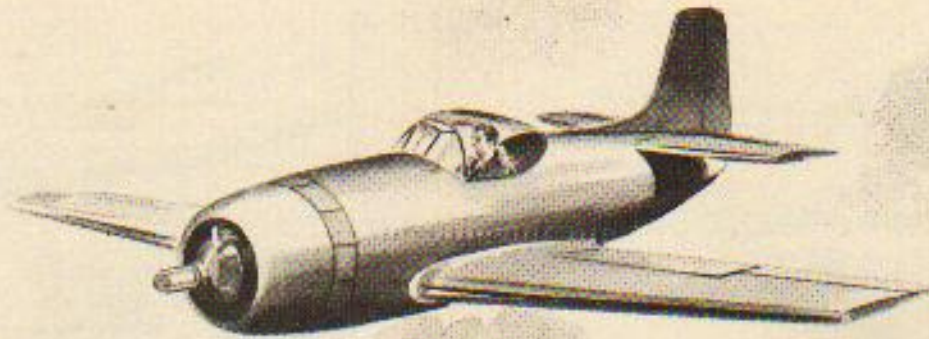

Actually, only about 10% of the air in the path of the engine is forced through the cowl, the remainder passing smoothly over the outside of the cowling. As a result there is little cooling drag—the power consumed in cooling amounts to roughly 5% of the bhp—and performance is not sacrificed because of the shape of the engine and its cowling.

TEMPERATURE CONTROL

The amount of heat transferred to the cooling air is roughly proportional to the mass airflow. Control of engine temperatures may, therefore, be accomplished by regulating the number of pounds of air that are forced past the engine in a given time by the cowling. Mass airflow in turn is regulated by varying the pressure drop across the engine. This may be done in one of two ways:

1. By Cowl Flaps

Fixed exit cowls are generally satisfactory on aircraft whose range of speed is small, so long as the exit gap is sufficiently large to provide the necessary airflow with the entrance pressure available at the lowest climbing speed. At the higher speeds of level flight the increase

in pressure at the cowl entrance forces more air past the engine than is actually required; but, as the speed range is low, the small waste of energy involved does not warrant the extra weight and complication of adjustable cowl flaps. On the other hand, with high performance aircraft there is an appreciable waste of power in forcing excess cooling air past the engine at high speeds, and the extra weight and complication of adjustable cowl flaps are accordingly justified.

At high speeds the exit is reduced so that only the required airflow can pass through. At low speeds the exit area is increased. This decreases the pressure behind the cylinders to compensate for the reduced frontal pressure, and so maintains the necessary drop across the engine.

Cowl flaps thus act as a throttle for the cooling airflow. The effective range of cowl flap opening is limited by aerodynamic considerations, which vary from installation to installation. For example: the parasite, or form drag of the aircraft is increased as the flaps are opened; and, if the flaps are opened too far, buffeting may result above certain airspeeds, and the control of the aircraft consequently disturbed.



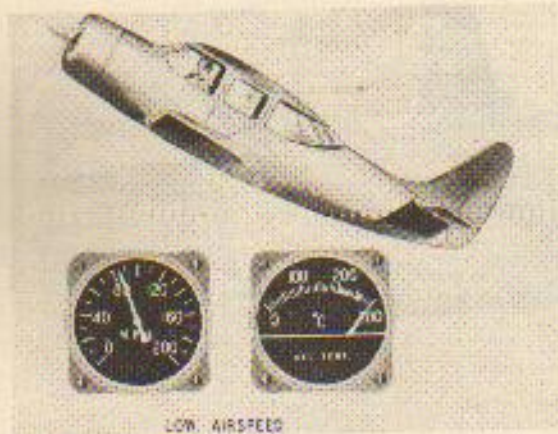

LOW AIRSPEED



HIGH AIRSPEED

2. By Air Speed

Any variation in the forward speed of the airplane affects the pressure at the face of the engine and, hence, the mass airflow past the cylinders. If airspeed can be increased without calling upon the engine for additional power—for example, by decreasing the rate of climb—the result will be a more effective cooling of the engine.

OTHER TEMPERATURE CONTROLS

There are also two ways of controlling the temperature of an engine, neither of which, strictly speaking, is effected by means of the powerplant's cooling system.

1. Fuel-Air Ratio.

The heat generated by combustion is greatest with a fuel-air ratio of approximately 0.067—slightly below the so-called lean best power mixture setting. (See page 26). If the mixture is

below this fuel-air ratio the excess of air in the charge reduces the combustion temperature. When the mixture is richer than this fuel-air ratio the presence of excess fuel reduces the combustion temperature. A measure of control over cylinder head temperatures can then be obtained by increasing the fuel-air ratio from automatic lean to automatic rich provided that the automatic rich mixture is sufficiently richer than best power. Generally, in the cruising range, advancing the mixture control from automatic lean to automatic rich will raise the mixture strength from near best economy up to approximately lean best power with the result that the cylinder head temperature will be increased rather than lowered.

2. Power.

A reduction in power will also cause a drop in cylinder head temperatures. To obtain the greatest effect, power should be reduced by lowering both rpm and manifold pressure.

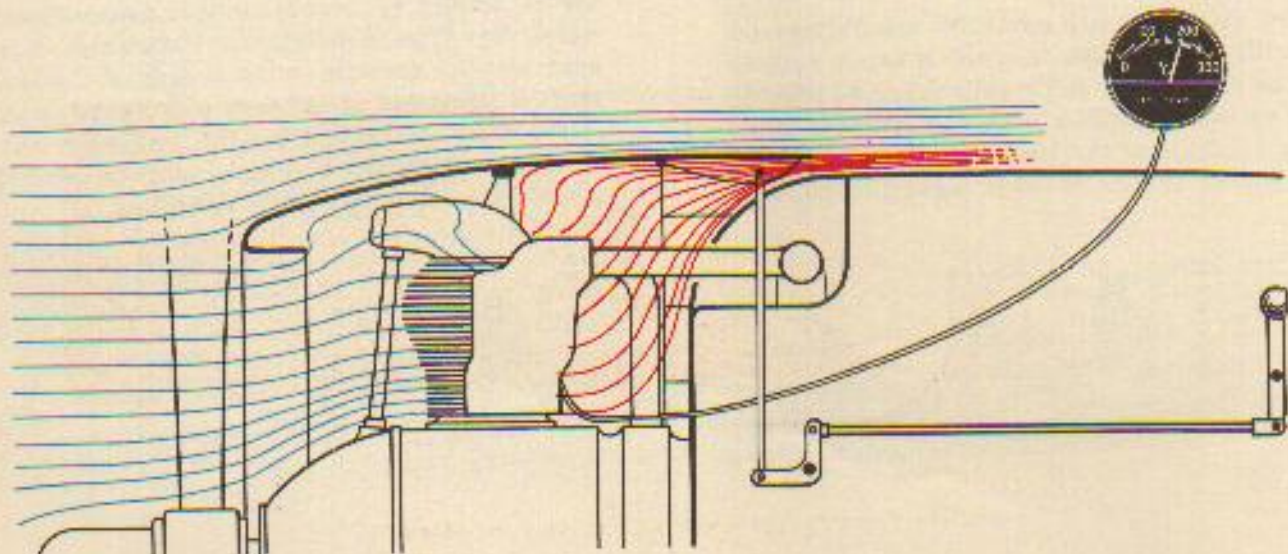

INDUCTION SYSTEM

FUNCTION

The function of the induction system is to deliver a combustible mixture of fuel and air to the cylinders and, subject to intelligent control by the operator, to deliver the charge:

- at the proper fuel-air ratio for the particular type of operation demanded;
- in sufficient quantities to meet all power requirements;
- at a temperature that will insure efficient combustion;

The induction system can conveniently be discussed under three general heads:

- Carburetion** — dealing principally with the carburetor and the means of obtaining the desired fuel-air ratios.
- Supercharging** — which is chiefly concerned with providing an adequate airflow without too great a temperature rise or power restriction.
- Ducting** — which deals with the engine's air conditioning system.

1. CARBURETION

THE FUEL-AIR RATIO

The determination of the combustible range of a gasoline-air mixture is a simple and sporting investigation: The first step is to light a match in air containing no gasoline vapor. The match will burn, but there will be no explosion—proving that air merely supports combustion. The second step is to remove carefully all the fuel vapors above an open dish of fuel, and then dash a lighted match into the liquid. If the experimenter succeeds in getting the lighted match into the gasoline, the flame will be extinguished—proving that gasoline by itself is not combustible. More than likely the investigator will not

have completely removed the gasoline vapors, and he will have succeeded in getting the burning match only part way to the fuel when he will be made painfully aware of the forces that act on the piston of an internal combustion engine — proving that a mixture of gasoline vapor and air can be violently explosive, and that home experiments should be rigidly controlled.

The variations in energy with different mixtures of gasoline and air are illustrated below:

The weight of fuel divided by the weight of air in a given mixture is known as the latter's fuel-air ratio (F/A). It will be noticed that the range of usable fuel-air ratio is relatively small.

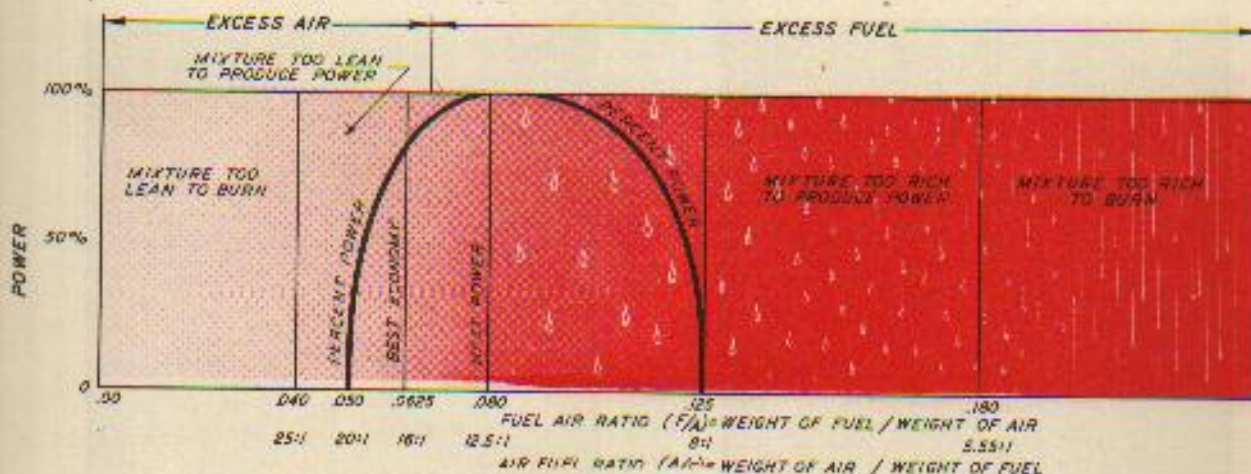

Fig. 4 — Combustible Range of Fuel and Air Mixture

"BEST POWER" and "BEST ECONOMY" MIXTURES

If the power output (brake horsepower) and rpm of an engine are kept constant, and the mixture strength is varied from one extreme to another, it will be found that:

1. The manifold pressure required to produce the given power at the given rpm will be at a minimum when the fuel-air ratio is in the range of .074 - .080. By definition, .074 fuel-air ratio is "lean best power" mixture and .080 fuel-air ratio is "rich best power" mixture. Any mixture between .074 and .080 fuel-air ratios is a "best power" mixture.
2. The quantity of fuel required to produce the given power at the given rpm will be at a minimum when the fuel-air ratio is approximately 0.0625 with the usual spark advance settings and compression ratios employed. This is, again by definition, the "best economy" mixture.

The relation between best power and best economy are more precisely shown in Fig. 5.

IDEAL AND ACTUAL FUEL-AIR RATIOS

Were there no considerations other than power and economy, the ideal fuel regulating device would be one which would give a fuel-air ratio of 0.080 when maximum performance was desired, and which could be used to give a fuel-air ratio of 0.0625 when fuel economy was the primary consideration. Plotted in the form of a conventional carburetor performance curve, the relation between fuel-air ratio and power (sometimes expressed as airflow) are illustrated by the solid lines in Fig. 6.

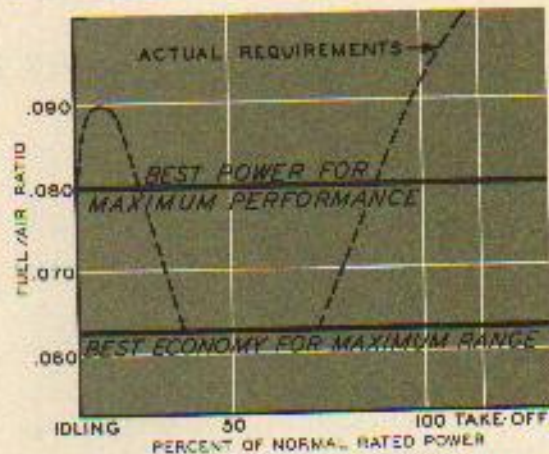

Fig. 6 - Ideal and Actual Fuel-Air Ratios

In practice, however, engine requirements call for deviations from this ideal curve, and the actual performance curve looks more like the one drawn in dotted lines in Fig. 6.

The principal reasons for departing from the ideal fuel-air ratios are:

1. To insure smooth operation in the idling range, when the engine is cold.
2. To protect the engine from detonation in the high power range.

IDLING MIXTURES

Idling and taxiing present special conditions. The fuel-air ratio must be held within narrow limits: to prevent the spark plugs from fouling because of excessive richness, on the one hand, and, on the other, to avoid any tendency to "die" or accelerate hesitatingly because of over-leanness. Properly set idle mixtures will make possible continuous smooth idling without danger of fouling.

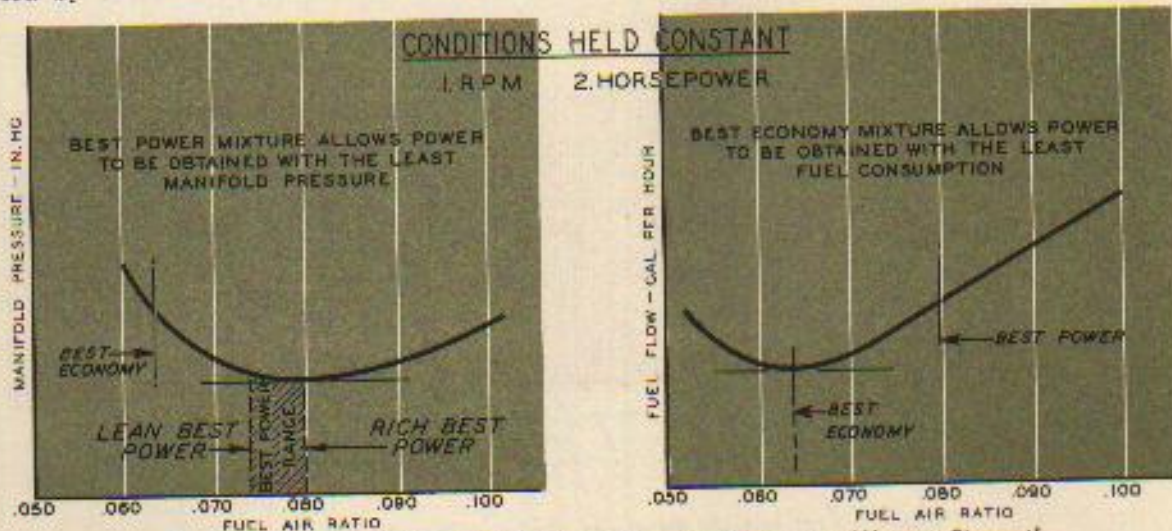
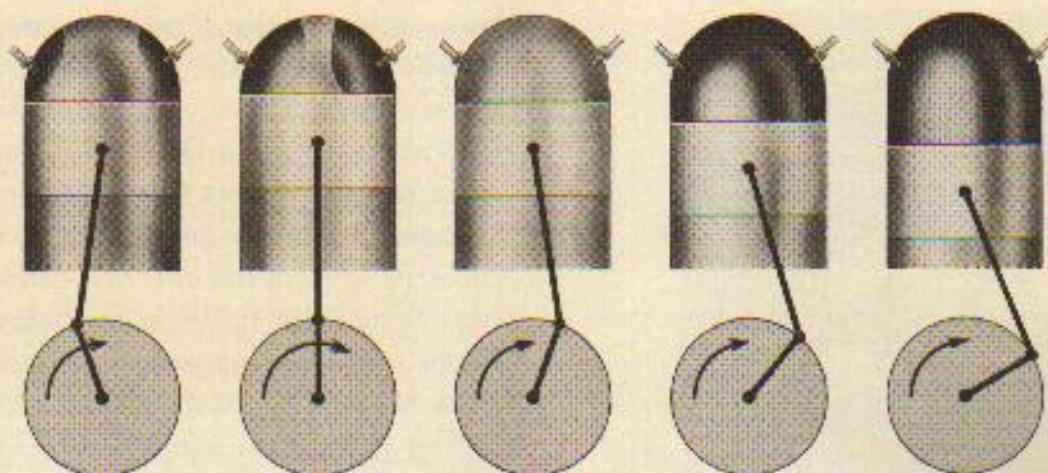

Fig. 5 - Determination of Best Power and Best Economy Mixture Strength



NORMAL COMBUSTION

DETONATION

Normal combustion is rapid, but it is by no means an instantaneous explosion. The charge burns evenly and smoothly, the flame front advancing at a measurable rate—about 35 feet per second when combustion begins, increasing to roughly 150 feet per second, and finally slowing down as the process nears completion.

If sufficiently heated and compressed, any combustible mixture of gasoline vapor and air will catch fire. Accordingly, if the temperature and pressure of the unburned portion of the fuel-air charge reach critical values, combustion

will begin spontaneously and simultaneously throughout the unburned charge. The result is a sudden and violent explosion of the charge known as detonation.

Detonation is the spontaneous combustion of the unburned charge *after* normal ignition. It sets in motion pressure waves that travel at supersonic speed and produces generally harmful effects on combustion chamber parts. Frequent operation with detonation will usually be evidenced at overhaul by dished piston heads, collapsed valve heads, broken rings and ring

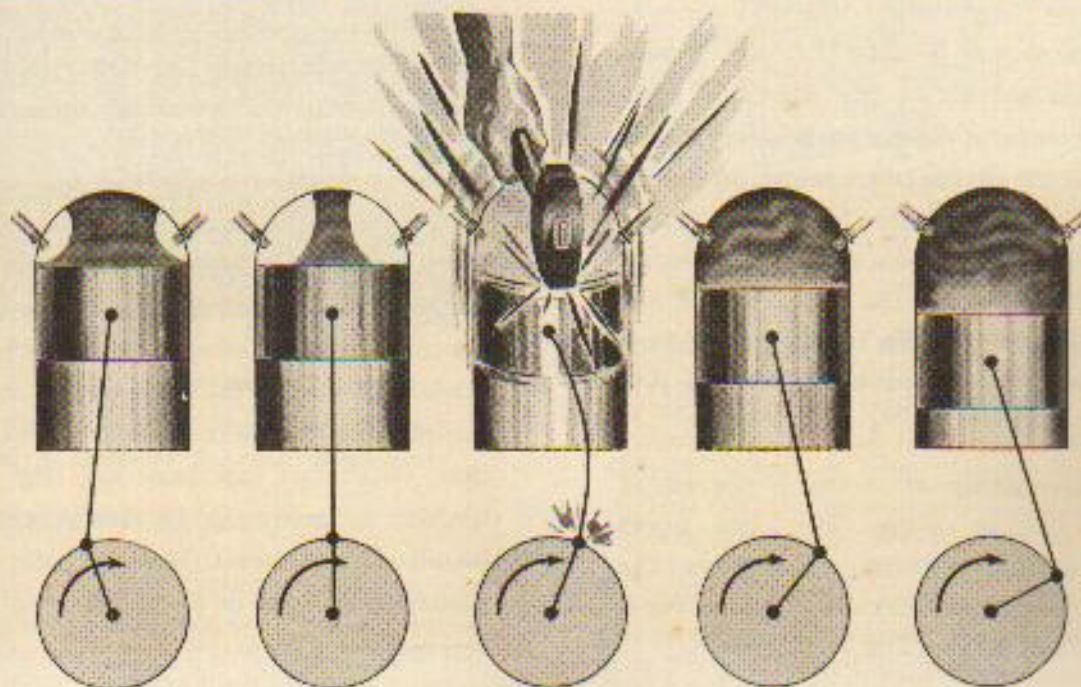

DETONATION



A few seconds of pre-ignition can do this.

lands or eroded portions of valves, pistons and cylinder heads.

As detonation cannot usually be recognized from the cockpit through roughness, sound, head temperature increase or loss of power, protection from its possible occurrence must be provided by the design of the engine augmented by adherence to the operating limits and proper maintenance.

Detonation occurs because the final remaining unburned portion of the charge is overheated and control of detonation is accomplished by control of the charge temperature. In the design of the engine, cylinder head cooling, fuel grade, cylinder compression ratio, spark timing and heat rise through the supercharger are factors affecting detonation tendency since they influence the temperature of the charge just prior to combustion.

An effective means of control is the use of excess fuel in the charge. The extra liquid lowers the charge temperature and lowers the rate of combustion so that the final portion is still cooler than its kindling temperature.

Operational control of detonation also is di-

rected towards keeping the charge temperature within safe limits. The proper fuel grade must be selected, limits of manifold pressure, rpm, supercharging and cylinder head temperature must be respected, not from fear of immediate failure but from the knowledge that operation in excess of the limits will cause damage which may bring about failure in the future.

An erroneous impression has carried over from the days of unsupercharged engines and is held by many operators—that increased rpm relieves a condition of detonation. This is directly opposite from fact. Increased rpm increases the speed of the internal supercharger which elevates the charge temperature making the situation worse. As with practically all engine difficulties, *decreased* rpm is the proper remedy if detonation is present and recognized.

Preignition is the uncontrolled firing of the charge *in advance* of normal ignition. This premature combustion results in excessive pressure during the final portion of the compression stroke with attendant destructive temperatures. Any sustained operation for a brief period in this condition can result in burned pistons, broken cylinder heads, scuffed cylinder walls, and damage to valves and sparkplugs.

The presence of preignition can usually be recognized in the cockpit by roughness, back-firing and possibly by a sudden increase in head temperature. It is caused by the presence within the combustion chamber of an area which is incandescent during the compression stroke and serves as an ignitor in advance of normal ignition. Detonation can pave the way for preignition by producing an eroded surface that becomes incandescent. Most probably lead deposits accumulated on the chamber surfaces are responsible.

Control of preignition is accomplished by

proper maintenance and operating procedures aimed at maintaining the combustion chamber in proper condition.

EFFECT OF DETONATION

As charge temperatures are raised with an increase in power, the tendency to detonate naturally increases as well. Because of this it is necessary to deviate from the ideal fuel-air ratio, and gradually enrich the mixture as the power is increased above approximately 67% of Normal Rated power. The minimum fuel-air ratio necessary to protect the engine is determined by test, and the resultant departures from the ideal curve will look something like Fig. 7.

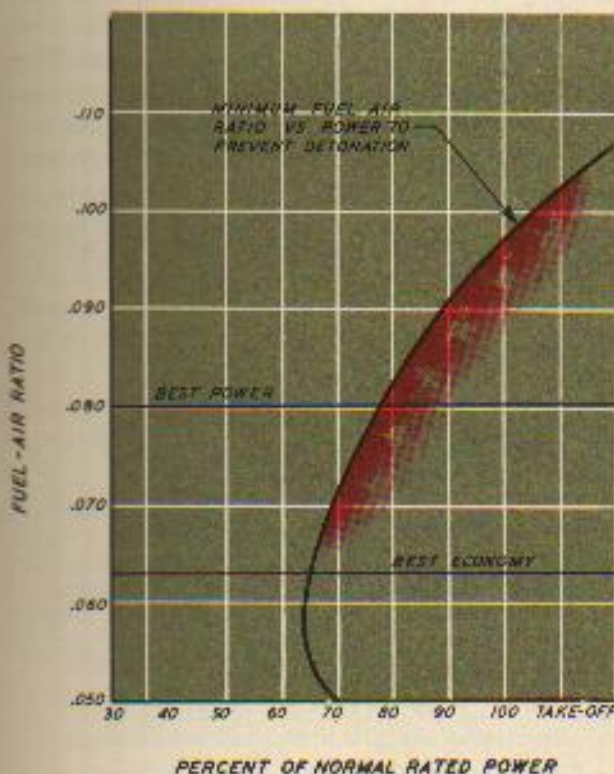

Fig. 7 — Departure From Ideal Fuel-Air Ratio Required in Order to Suppress Detonation

THE COMPLETE FUEL-AIR CURVE

After making the necessary adjustments for the idling and power ranges, the completed curve representing the engine's fuel-air ratio requirements throughout its entire operating range will be somewhat like Fig. 8.

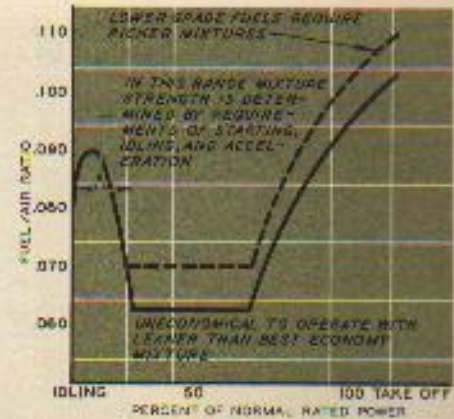

Fig. 8—Complete Fuel-Air Ratio Requirements

THE CARBURETOR

It is conceivable that mixture regulation could be accomplished by means of a manually operated valve inserted in the fuel line. But it may be reasonably doubted that any pilot, or pilot's assistant, by continually taking stock of the conditions under which he is operating, and referring them to his fuel-air ratio curve, could



regulate the mixture with sufficient rapidity or accuracy to accommodate the constantly varying demands of the engine. Mixture regulation is accordingly turned over to a mechanical device which performs this function automatically. This device is the carburetor.

Mass airflow, or the weight of air consumed per hour, provides the link by which the fuel metering of the carburetor is coordinated with the power demands of the engine. Mass airflow and power are directly related, and if the carburetor is made sensitive to changes in airflow, it can be made responsive to variations in power

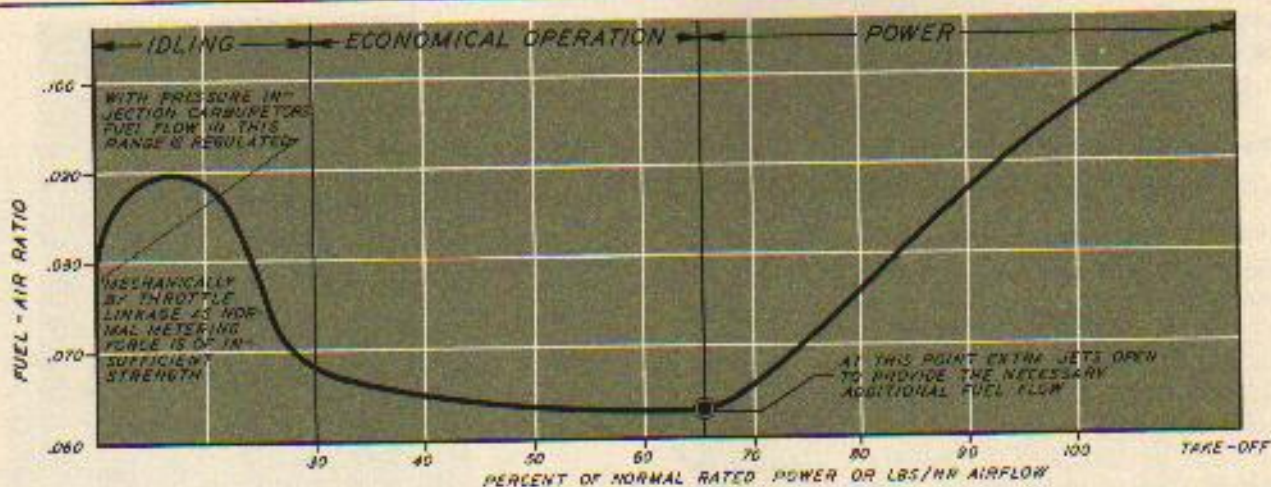

Fig. 9 - Final Fuel-Air Curve

and so provide the fuel flow appropriate to each part of the engine's operating range. In other words, the fuel metering forces in the carburetor are adjusted to respond to airflow in such a way as to produce a fuel-air ratio power curve similar to Fig. 9, which is typical for all carburetors, and which closely resembles the fuel-air ratio curve just discussed.

For purposes of discussion, carburetors may be divided into two general classes:

1. Non-automatic.
2. Automatic.

NON-AUTOMATIC CARBURETORS

As previously pointed out, proper fuel regulation depends on the ability of the carburetor to measure correctly the weight of air flowing

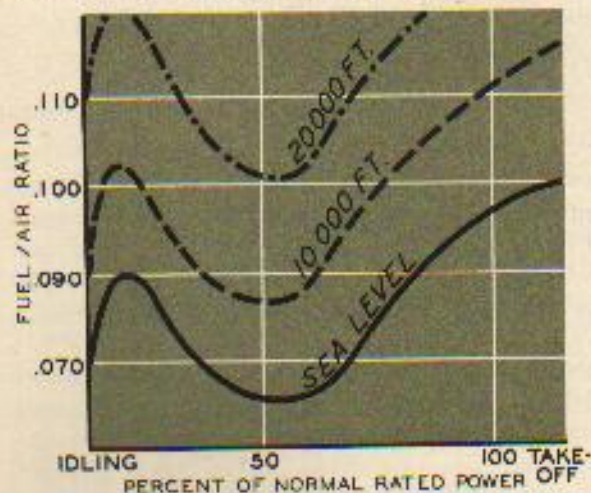
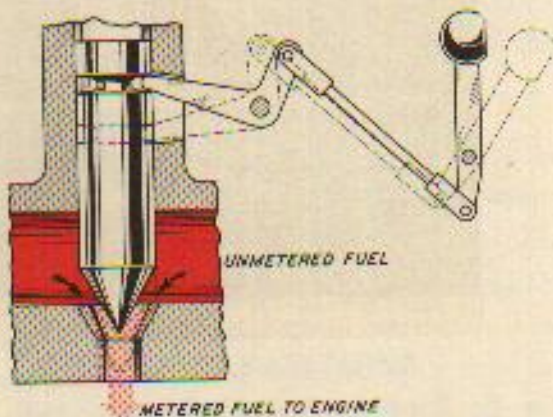

Fig. 10 - Effects of Altitude on Uncompensated Carburetor

through it. If altitude or temperature are increased, the same weight of air will occupy a greater volume, and thus will flow through the carburetor with a higher velocity. This has the effect of increasing the fuel metering forces. The simple airflow measuring device of the non-automatic carburetor does not fully compensate for this extra force, with the result that the mixture becomes richer as temperature or altitude is increased. The effect on the basic metering curve of an increase in altitude is illustrated in Fig. 10.

To compensate for this enrichment, a manually operated mixture control mechanism is incorporated in the carburetor.



By moving the mixture control lever, the area of the metering jet (orifice) is restricted or enlarged, and the fuel flow correspondingly decreased or increased.

If no adjustment is made, the fuel-air ratio will normally be somewhat richer than the minimum required by conditions in the cruising range. To realize the maximum fuel economy

possible for this type of operation, the mixture must be manually leaned.

Non-automatic carburetors are usually restricted to the float type carburetors.

AUTOMATIC CARBURETORS

Automatic carburetors incorporate an automatic mixture control unit, sensitive to pressure and temperature, which compensates for changes in both altitude and temperature. These carburetors meter fuel in such a way as to conform to the basic fuel-air ratio curve throughout all flight conditions, and it is therefore unnecessary to vary the position of the mixture control lever to maintain the manually selected mixture setting.

Two manually selected mixture settings are usually available:

1. **Automatic Rich** (Take-Off and Climb)
2. **Automatic Lean** (Cruise)—to provide mixtures giving the greatest possible fuel economy; limited by engine power and grade of fuel; and generally permissible only under favorable conditions of power and cooling.

The carburetor performance curve, with the two selective mixture settings, is illustrated by Fig. 11.

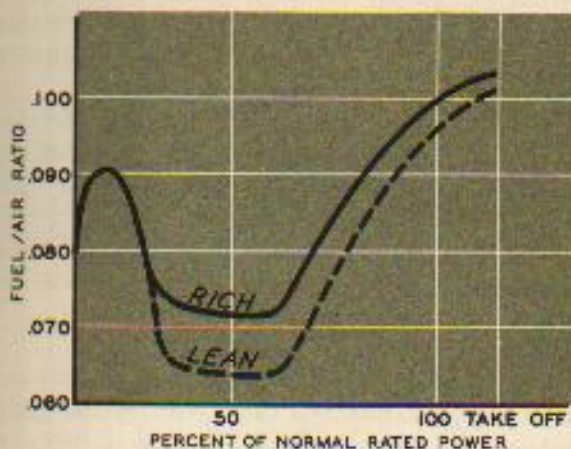

Fig. 11 — A Setting Curve for an Automatic Carburetor

* The above mixture position designations have been used in conjunction with most engines manufactured by Pratt & Whitney Aircraft and of other manufacture that are provided with pressure injection carburetors. Other designations may be used by other manufacturers. Recently some pressure injection carburetors have "rich" and "normal" mixture control positions instead of "automatic rich" and "automatic lean", and in the future different terms may apply.

It is the usual practice to limit the use of the automatic lean setting to powers below 67% of Normal Rated power.

More recently some automatic pressure injection carburetors have mixture positions as follows:

1. **Normal** — This provides mixtures for all flight conditions except in some instances for take-off and final approach. For low powers it provides a mixture strength comparable to the automatic lean setting of other carburetors. At higher powers the mixture is enriched to give mixture strengths comparable to automatic rich.
2. **Rich** — This provides mixture strengths slightly richer than normal. It is used for all ground operation, and when critical engine cooling requires a mixture richer than that obtained with normal. In many instances it is the required mixture control position for take-off and final approach.

Automatic carburetors may be of either the float or injection types.

FUEL INJECTION.

Once the fuel has been metered in proportion to airflow, it is introduced into the air stream as a fine, atomized spray. In some induction systems the fuel is atomized at the carburetor; in others this is accomplished by a so-called spinner discharge nozzle which discharges the fuel into the impeller. In both systems the action of the supercharger further assists the process of atomization and vaporization.

The above injection systems covered practically all aircraft engine applications prior to World War II. An additional system which injects the fuel directly into each individual cylinder is being offered by several engine manufacturers as standard or alternate equipment. This system permits the control of the amount of fuel furnished to each individual cylinder and results in a more nearly perfect distribution of the liquid portion of the mixture. This advantage may be somewhat offset if there is lack of perfect air distribution and by the increased weight and complexity of this arrangement. Continued development should result in the more widespread use of the direct injection system.

CONTROLS

The functioning of the carburetor is regulated by two controls:

1. **Manual mixture control lever.** This controls the fuel flow and so regulates the fuel-air ratio on non-automatic carburetors. On automatic carburetors it sets the mixture in either the Automatic Rich or Automatic Lean (Rich or Normal) position. (On some types of carburetors an additional position, known as Full Rich, is also provided. It is basically slightly richer than automatic rich, and is not subject to compensation by the automatic mixture control units with the result that the mixture strength undergoes further normal altitude increase.) On both types of carburetors the fuel flow may be stopped by placing the mixture control lever in the Idle Cut-off position. This is the normal way of stopping an engine. (Idling mixtures, as well as idling speeds, may also be adjusted, but only on the ground.)
2. **Throttle.** As the carburetor is at the air entrance to the engine, it is a logical place at which to provide some means of controlling the airflow. This is accomplished by the throttle, a valve which, by varying the area through which the charge air passes, controls the flow. Since airflow is directly related to power, the throttle is one, but not the only, means of controlling power.

On pressure type carburetors the fuel metering force established in proportion to airflow is of sufficient magnitude to be used for regulating mechanisms whose functioning must vary with power. An example of this is the automatic spark advance mechanism.

FUEL PRESSURE

The pressure of the fuel at the entrance of the carburetor has an important effect on the fuel-air ratio. If it does not fall within the specified limits, the carburetor will not meter fuel correctly in response to airflow. The operator has no control of the fuel pressure produced by the engine-driven fuel pump while in flight. Consequently, he should check to see that it registers correctly during the ground tests and make all necessary adjustments prior to take-off.

INSTRUMENTS

The fuel pressure gage is the only instrument connected directly to the carburetor. It is connected at the fuel strainer chamber and the pressure registered on the gage is the differential pressure between that of the fuel and that of the atmosphere. (Generally, at the carburetor entrance.)

In addition, three other instruments may be added to the induction system in order to assist in the control of induction system conditions and the regulation of fuel flow. These are:

1. **Carburetor Air Temperature Gage:**—The carburetor air temperature gage is usually attached in the air scoop elbow immediately upstream from the carburetor entrance, as the temperature measured at this location is the most reliable means of determining ice formation conditions. It also provides the reading of greatest stability for determining the temperature condition of the air for the purpose of power calculation. The temperatures measured at points in the induction system between the carburetor and the intake port do not provide a consistent means of measuring temperature and so do not provide a reliable means of determining charge density. By calibrating engine performance against variation in the temperature of the air measured at the carburetor entrance the effect of the variations in temperature at this point can be accurately determined.

Attempts have been made to measure the condition of the charge air at points between the carburetor and the intake port but they have not proved feasible, as stable readings of a fuel-air mixture cannot be obtained in the widely varying range of mixture strengths that are used.

2. **Fuel Flow Meter:** Fuel flow meters are sometimes provided on large aircraft in order to provide a close check on the rate of fuel consumed.

3. **Fuel-Air Analyzer:** On some installations, particularly those using non-automatic carburetors, fuel-air analyzers are the only means of determining whether or not mixture strength is within the proper range. This instrument determines the fuel-air ratio by sampling the exhaust gases.

2. SUPERCHARGING

POWER AND MASS AIRFLOW

The aircraft engine is a heat engine which derives its power from the burning of a mixture of fuel and air. The energy released by combustion is directly proportional to the weight, or mass, of the charge drawn into the cylinders. Accordingly, if the fuel-air ratio is kept constant at the "best power" mixture setting, the power developed in the cylinders will vary directly with the mass of air consumed. This basic relationship is independent of rpm, except as the latter affects the engine's capacity to handle air.

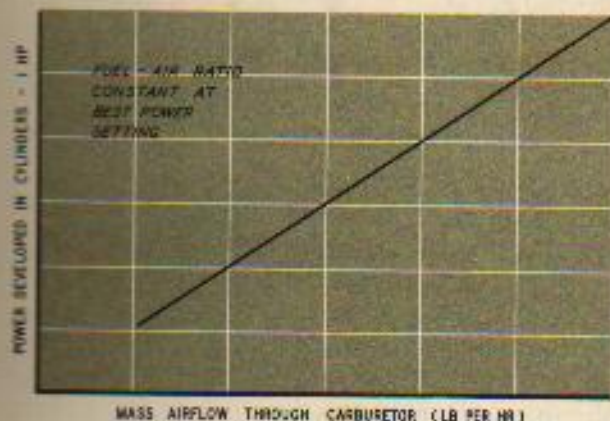

Fig 12. — Relation Between Power (IHP) and Mass Airflow

The power developed in the cylinders of an engine is known as the indicated horsepower (ihp). Not all of it is delivered to the propeller shaft, but, as suggested below, some of the ihp is lost in overcoming internal friction and in

driving the accessories; while some of it is absorbed in driving the supercharging mechanism. What remains as useful power available at the propeller shaft is known as brake horsepower, (bhp). In other words: $ihp = bhp + \text{power losses}$. Inasmuch as the power losses are functions of both rpm and power, bhp bears no fixed relation to rpm or to mass airflow. Although bhp is not strictly proportional to airflow, the connection between the two is nevertheless close, and in the final analysis the power output of an engine is controlled by the mass or weight of air flowing through the carburetor in a given time.

To obtain a high power output, it follows that the designer must provide some means of supplying the engine with a mass airflow sufficient for all conditions where high performance is demanded. To do this satisfactorily — over a wide range of altitude, and without too great a rise in the temperature of the fuel-air charge, or too great an increase in the complexity, weight, and drag of the installation—poses one of the most difficult problems in aircraft engine design.

THE ENGINE AS AN AIR PUMP

Air, or more strictly speaking, the oxygen in the air, is by volume and by weight the most important part of the combustible mixture. Roughly 13 pounds of air, or 2.6 pounds of oxygen, are consumed in the combustion of 1 pound of gasoline at "best power" mixture strength.

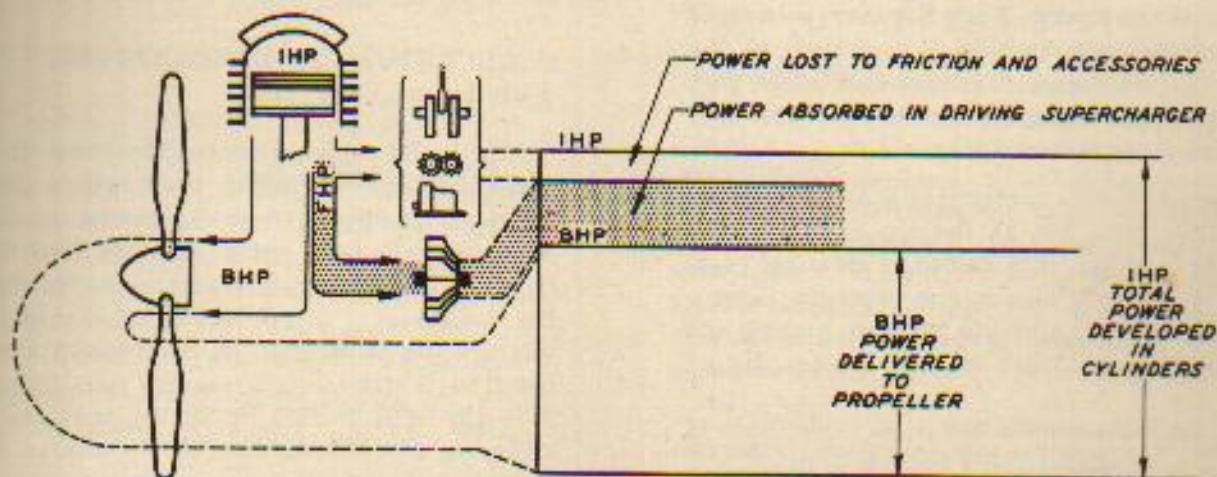

Unlike the rocket, which to be self-contained must carry both ingredients, the conventional aircraft carries only one ingredient in its tanks and flies through the other.

The internal combustion engine may, accordingly, be thought of as an air pump, whose performance depends in large measure on its capacity. Half of each power cycle is devoted to pumping air. As the piston descends during the intake stroke, air is drawn into the cylinder. During the exhaust stroke it is returned to the atmosphere, as a part of the exhaust gases, by the pressure of the piston. In the course of the compression and power strokes the engine takes time out from pumping to produce enough power to keep itself going and deliver a reasonable balance at the propeller shaft.

MANIFOLD PRESSURE

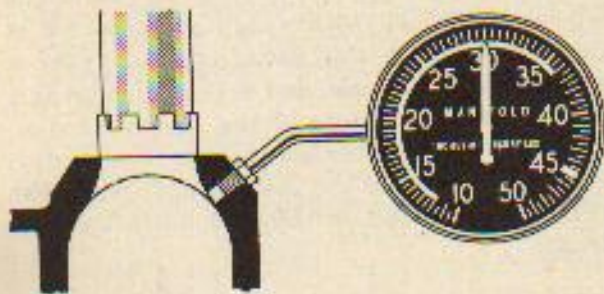

The weight of air consumed by an engine depends primarily on the total piston displacement, the rpm, the temperature of the charge, and the pressure existing at the intake ports. If the last of these factors is increased, a greater quantity of air is forced into the cylinders, and, so long as the fuel-air ratio and other factors remain constant, the result is to increase the weight of the charge. Since the energy released by combustion is in turn proportional to the weight of the charge, it follows that intake port pressure is an important index of power whenever the other factors are known.

In practice this pressure is not measured at an intake port, but at the rim of the supercharger collector. It is known as manifold pressure, or absolute blower rim pressure (abrp), or even manifold absolute pressure (map), and is expressed in inches of mercury (in. Hg.).*

* In. Hg. is the measure used in the United States of America. Other countries may use different units; for example in England manifold pressure is expressed in psi "boost" above sea level atmospheric pressure.

It is an absolute pressure, measured from zero psi, and not a "gauge", or differential pressure, measured from some reference point, such as atmospheric pressure.

Any variation or restriction of airflow affects the pressure at the collector rim. Manifold pressure is, therefore, regulated chiefly by the carburetor throttle valve. Secondarily, it is controlled by the pressure which exists at the car-

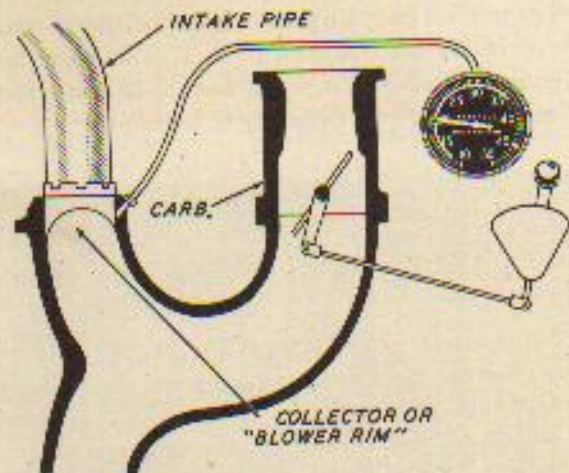

buretor entrance as the result of altitude, ram, or the operation of an auxiliary air compressor or supercharger.

Manifold pressure, it should be noted, is not power, but merely a convenient index for measuring one of the several factors affecting power. It is only in combination with rpm, and after making certain necessary corrections for carburetor air temperature, that manifold pressure may be used in making an approximate determination of bhp by reference to the appropriate operating curves.

CARBURETOR AIR TEMPERATURE AND MASS AIRFLOW

Any factor which changes the mass of the fuel-air charge will affect the engine's power output. The effects of variations in manifold pressure have been noted. Another important factor is the temperature of the charge. Since the weight of a given volume of the fuel-air mixture at a given pressure is inversely proportional to its absolute temperature (abs. temp. = $F + 459$ or $C + 273$), it follows that any increase in the temperature of the charge at a given manifold pressure results in a decrease in

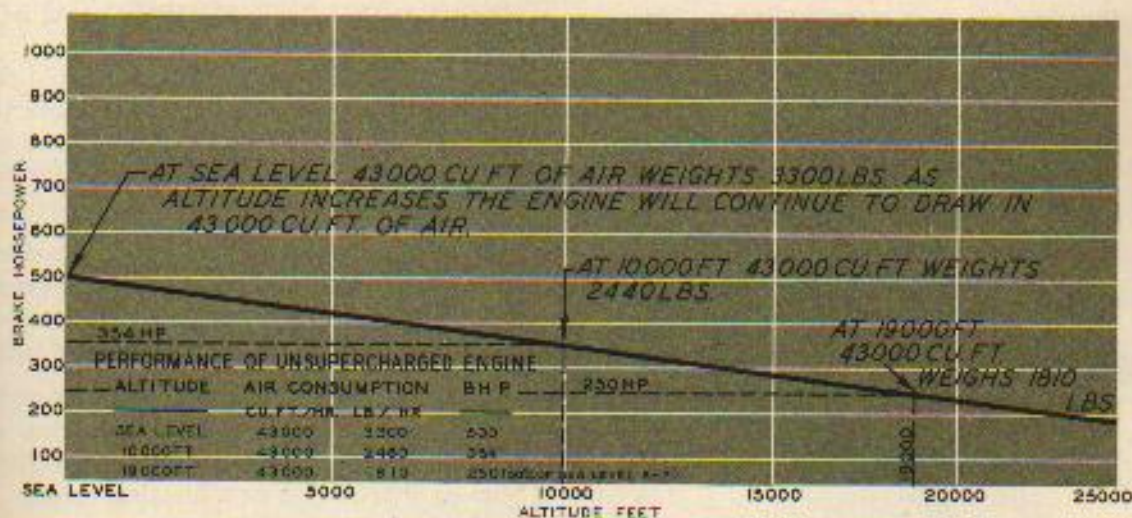

Fig. 13 — Power vs Altitude — Unsupercharged Engine

its density and weight, and hence in the amount of energy available from its combustion.

In practice the temperature of the fuel-air charge itself is not measured. Instead, the temperature of the charge air is taken as it is about to enter the carburetor prior to the injection of the fuel; and, in establishing safe carburetor air temperature limits, allowance is made for the cooling effect of fuel vaporization, for the heat rise due to compression in the supercharger, and for other temperature changes occurring between the carburetor and the intake pipe.

High carburetor air temperatures are undesirable, not only because they result in a loss of power, but also because they may lead to detonation and consequent engine failure. It thus becomes one of the principal functions of the induction system to deliver the fuel-air charge to the cylinders at the proper temperatures.

THE UNSUPERCHARGED ENGINE

If the fuel-air charge is forced into the cylinders simply by the pressure exerted by the atmosphere, the engine is called a "naturally aspirated" or unsupercharged engine. ("Aspirate" means to draw by suction.) Such an induction system satisfies the requirements of moderate performance at low altitudes. Primary training planes are often equipped with such engines.

However, once this type of engine has left the ground its limitations become apparent. If the rpm is held constant and the throttle fixed in

the wide open position, manifold pressure will be found to decrease as altitude increases, and the impression of a loss of power would be confirmed by a torquemeter. The reason for this is to be found in the ability — or, better, inability — of the engine to pump sufficient air.

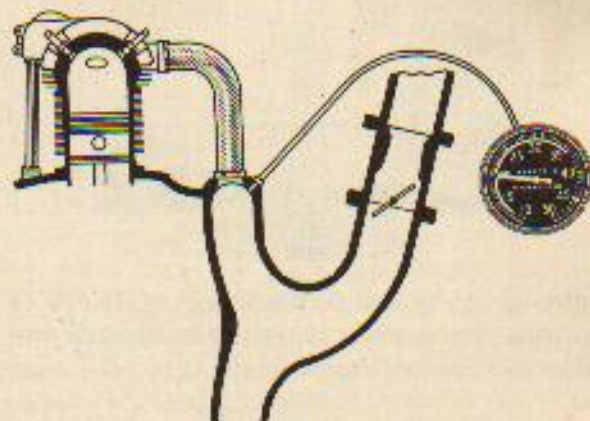

Assume, for example, that an engine delivers 500 bhp at sea level and, to produce this power, consumes in one hour 43,000 cu ft of air weighing 3,300 lb at sea level. At an altitude of 10,000 ft, 43,000 cu ft air weighs 2,460 lb and at 19,000 ft weighs only 1,810 lb. Since the power output of the engine depends on its ability to consume pounds rather than cubic feet of air, it follows that the power will decrease with altitude much as shown in Fig. 13.

The relation between altitude, weight, and volume can be illustrated in another way. At sea level, the 3,300 lb of air occupy 43,000 cu ft

— about the size of a two-story building. At

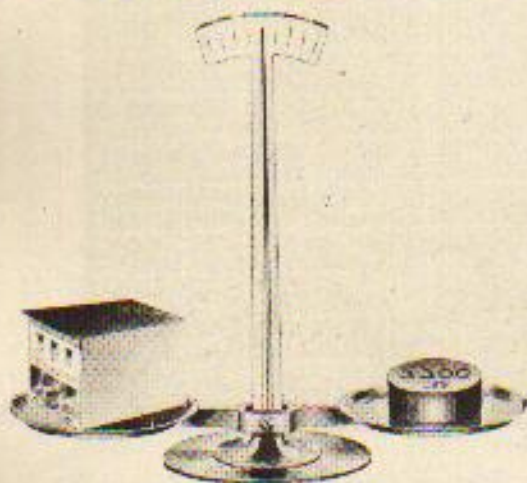

10,000 ft this same weight will occupy 58,200 cu ft — which will require an extra story on the

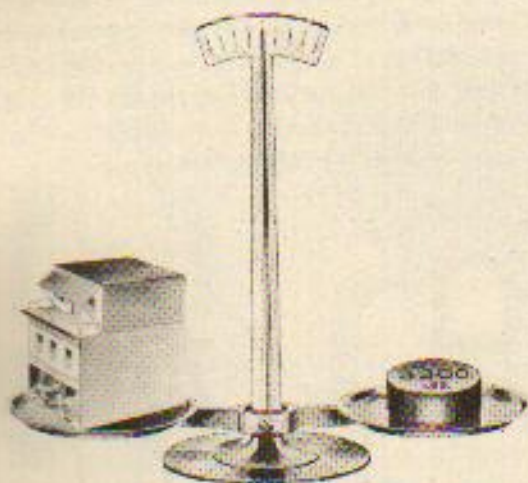

building. At 19,000 ft it will occupy 78,000 cu ft — and the original two-story building is now three and one-half stories high.

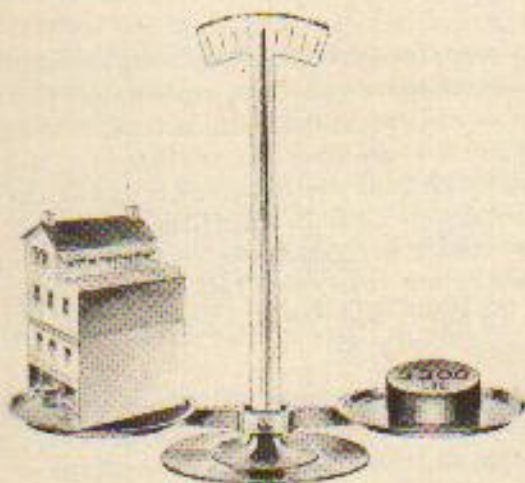

INCREASING THE PUMPING CAPACITY

The problem of designing an engine that will maintain its power output at altitude thus resolves itself into one of increasing the engine's air-pumping capacity. Three different methods may be used to accomplish this:

1. **Increase piston displacement** by adding or enlarging cylinders. This is a cumbersome method, since it increases the size of the engine without increasing the ratio of power to weight.
2. **Increase rpm.** This raises the pumping rate of the engine, but offers only a partial solution to the problem, as centrifugal and reciprocating forces shortly impose a limiting speed.
3. **Supercharge** by incorporating in the engine a special air pump whose primary function is to compress more weight of air into the fixed volume of air handled by the pistons. This is the method most commonly used to raise an engine's air pumping capacity, since it calls for no increase in rpm or of power section size, and adds relatively little to the overall weight of the powerplant.

THE SUPERCHARGER

The conventional supercharger is a centrifugal air compressor placed between the carburetor and the intake pipes. It is usually housed between the power and accessory rear sections. Its principal features, which are shown on p. 37, consist of three main units:

1. **Impeller.** After leaving the carburetor, the air passes through the supercharger throat to the impeller. The impeller is driven at roughly 6 to 14 times crankshaft speed, and because of its high rotational speed imparts a large velocity energy to the air.
2. **Diffuser.** As the fuel-air charge leaves the impeller it passes into the diffuser. The vanes of the diffuser ensure a smooth flow while allowing the charge to slow down as it moves outward, with the result that the velocity pressure acquired from the impeller is transformed into static pressure.
3. **Collector.** After leaving the diffuser, the charge is stored momentarily and equalized in the collector, whence it is drawn to the cylinders through the intake pipes. It is at the collector rim that manifold pressure is taken.

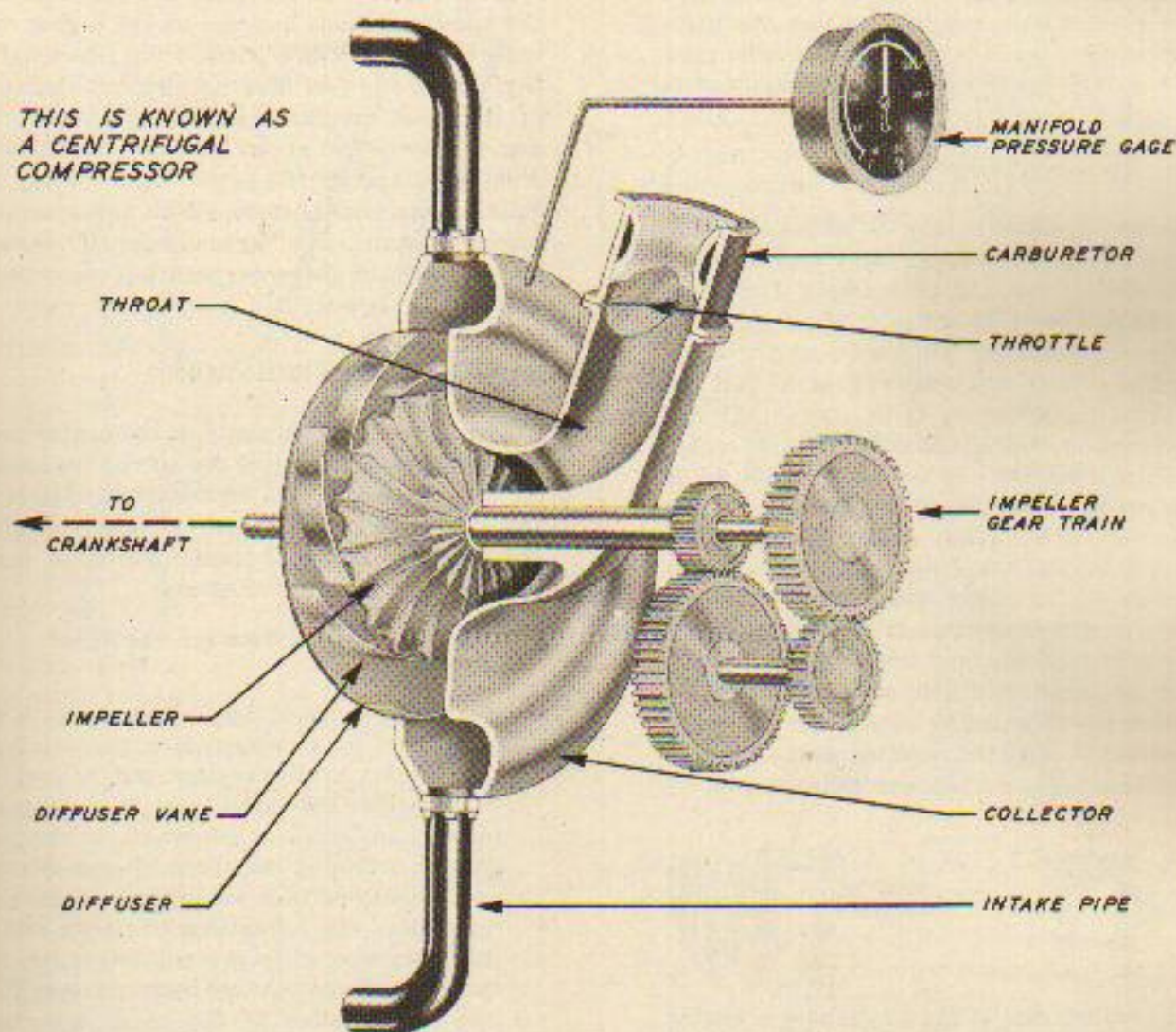

SECONDARY EFFECTS OF SUPERCHARGING

While the principal function of supercharging is to increase mass airflow by raising the pressure, and hence the density and weight of the fuel-air charge, several other important effects are also associated with it. These are:

1. **More even distribution** of the fuel-air charge to the cylinders, because of the radial construction of the supercharger and its axial location.
2. **More complete vaporization** of the fuel. The fuel is injected into the air stream at the carburetor or at the entrance to the supercharger through a spinner discharge nozzle attached to the impeller shaft. Vaporization is assisted by the whirling action of the impeller as well as by the heat of compression.
3. **Rise in temperature** of the fuel-air charge as a result of compression. While this assists vaporization, at the same time it tends to lower the density of the charge and so reduce power at any given manifold pressure. In extreme cases these high temperatures may lead to detonation. The temperature rise increases rapidly with impeller speed, and, as a consequence, an engine may actually be able to deliver more power at a low rpm than at a high rpm, since the lower charge temperatures permit operation at higher manifold pressures without danger of detonation.
4. **Absorption of power** by the supercharging mechanism. Additional pumping power is necessarily required for any increase in airflow. Since the power required to deliver a given weight of air varies roughly as the square of the tip speed of the impeller, it follows that, for any given

rpm and manifold pressure, the power absorbed by the supercharger will be kept to a minimum by operating in the lowest possible impeller gear ratio that will provide the desired engine performance.

“GROUND BOOSTING”

Suppose a supercharger is installed in the induction system of the normally aspirated engine previously used as an example. The cylinders will still pump 43,000 cu ft of air per hour, but the supercharger will compress a greater amount of air into this volume. Assume that the equivalent of 60,000 cu ft of outside air are compressed into the 43,000 cu ft per hour capacity of the cylinders. At sea level 60,000 cu ft of air weigh 4,600 lb, while 43,000 cu ft, as previously noted, weigh only 3,300 lb. Since indicated horsepower (ihp) is proportional to mass airflow, the engine should respond to this increase in airflow by producing 700 horsepower in the cylinders, whereas, with the original airflow it produced only 500. Neglecting friction and other power losses, 50 horsepower must now be diverted to drive the impeller, so the net gain in available brake horsepower (bhp) is 150.



The performance of the supercharged engine compared with that of the normally aspirated engine is illustrated in Fig. 14.

If the engine is built sturdily enough to absorb the additional loads imposed by the higher cylinder pressures which result from supercharging, and if the fuel does not detonate because of increased pressures and temperatures, the engine may be run at sea level with its throttle wide open, and its full power capacity may be called upon at any altitude. Such a supercharged engine is known as a “ground boosted” engine, and is typical of the power plants of many basic training airplanes.

ALTITUDE SUPERCHARGING

The air pumping capacity of the engine may be increased by enlarging the size of the impeller or by driving it at a higher speed relative to the crankshaft. The degree of supercharging obtainable by either of these methods is, however, subject to two limitations:

1. Temperature Rise Through the Supercharger:

The compression of the fuel-air charge is accompanied by a temperature rise attributable in part to compression and, in part, to fluid friction and turbulence. It is desirable to keep this rise to a minimum for the purpose of obtaining maximum charge density and, more important, the amount of this rise determines the limitations of power which must be imposed to prevent detonation because of excessive charge temperatures. This last consideration is the most important limitation placed on the tip speed at which the impeller may be driven.

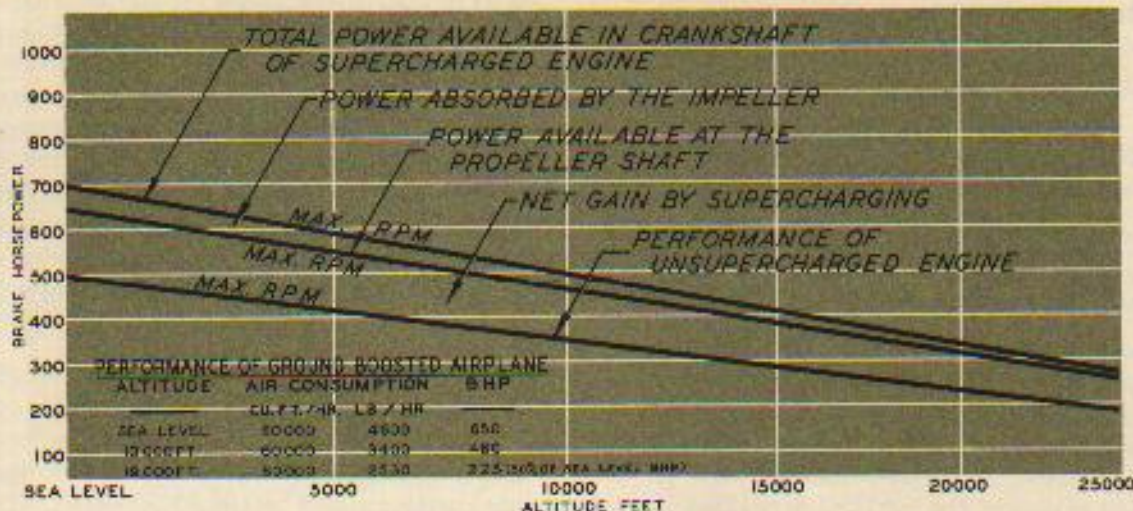
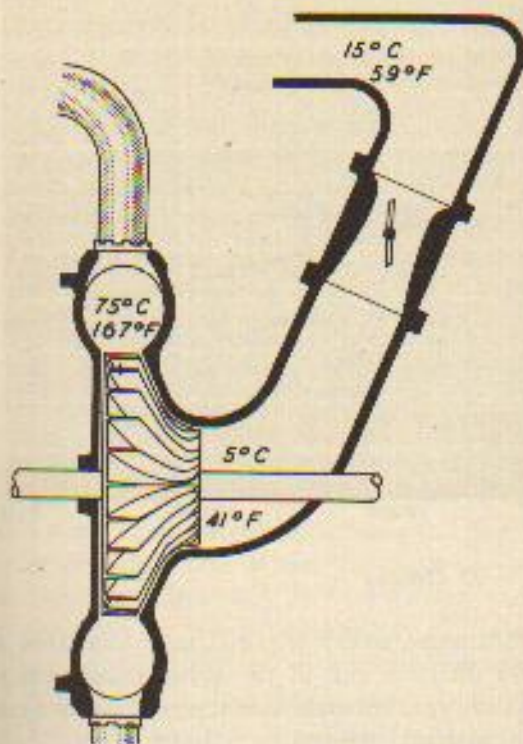

Fig. 14 — Power vs Altitude — Unsupercharged and Supercharged Engines



2. Power Absorbed by the Supercharger :

As previously stated, the power required to deliver a given weight of air varies approximately as the square of the impeller's tip speed. Conceivably, an impeller speed could be reached above which it would no longer be efficient to drive the impeller because of the excessive fraction of the engine power absorbed by the supercharger. However, the limitations imposed by temperature rise will be reached considerably in advance of this speed.

To obtain increased performance from the engine previously used as an example, a higher capacity supercharger is installed in place of the one which provided the "ground boost." The impeller of the new supercharger has a higher tip speed, and is assumed to operate just within the detonation limits imposed by the temperature rise. It supplies the cylinder pumping capacity of 43,000 cu ft per hour with the equivalent of 85,000 cu ft of air per hour. At sea level 85,000 cu ft of air will weigh 6,500 lb, and the power potentially available at the crankshaft (again neglecting friction losses) will be increased from 700 to 1,000 horsepower. The higher capacity impeller, however, absorbs 100

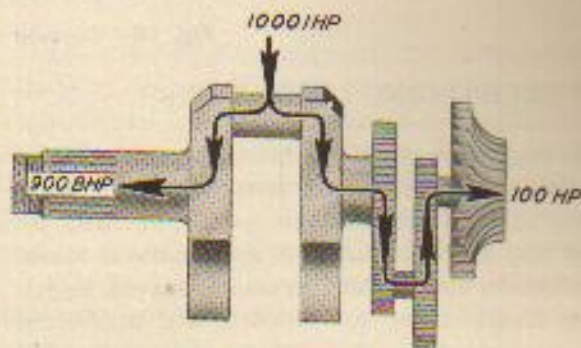

horsepower, instead of 50, leaving 900 potentially available at the propeller shaft.

The performance of the engine equipped with the higher capacity supercharger would be illustrated by the chart in Fig. 15, provided it were possible to use at every altitude all of the power there potentially available.

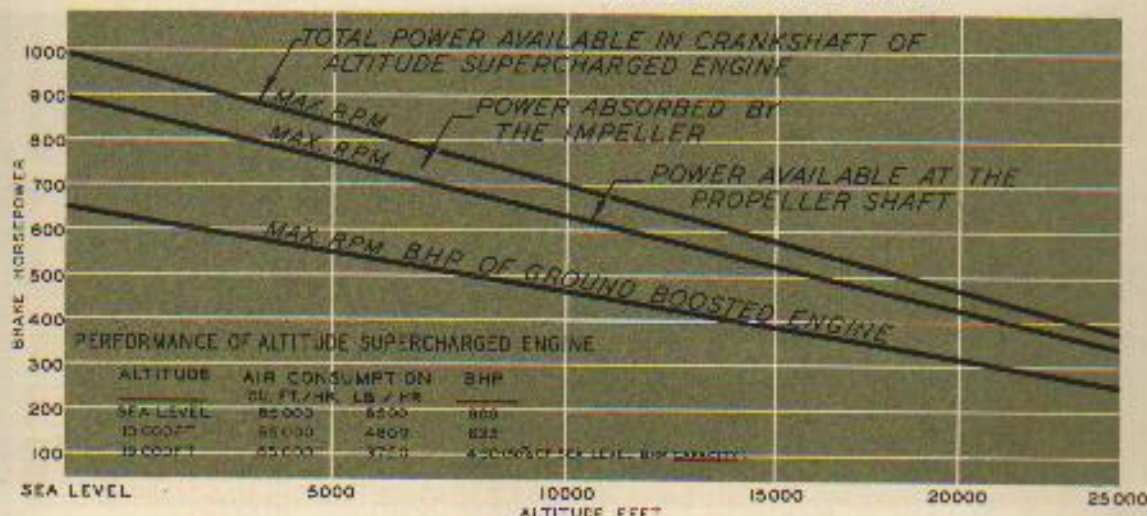

Fig. 15 — Power vs Altitude — Highly Supercharged Engine

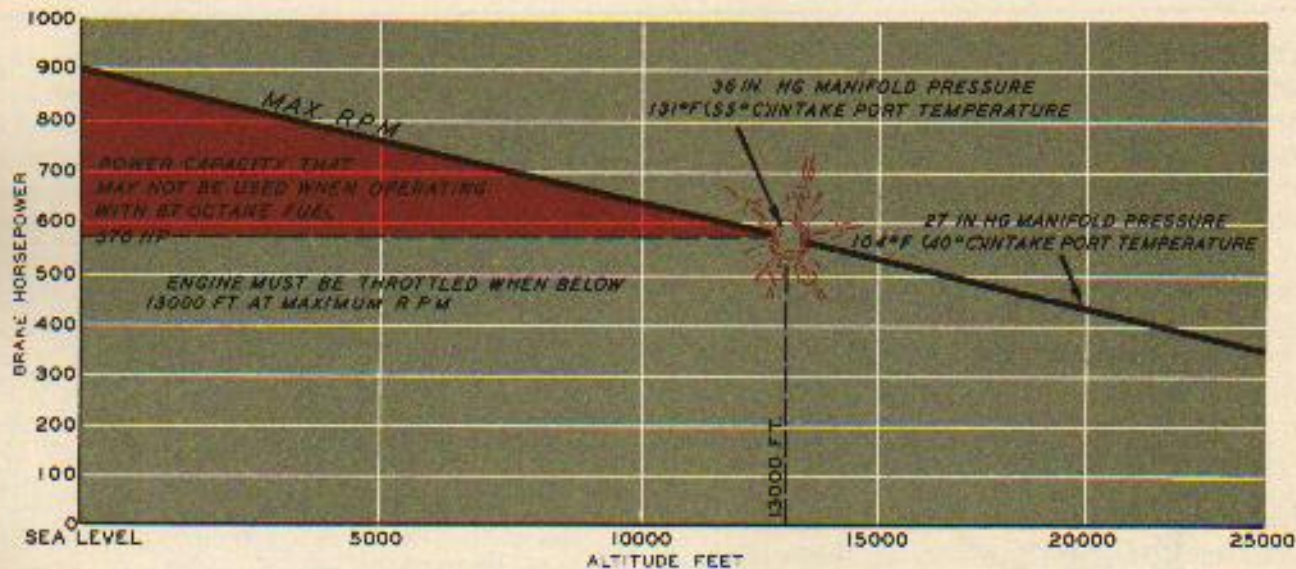

Fig. 16 — Descent Performance — 87 Octane

SUPERCHARGING LIMITATIONS

A maximum of 900 bhp is only potentially available, however, at the propeller shaft. How much of this potential power can actually be used may be determined, if the engine is taken to altitude, and a very gradual descent begun from 25,000 ft at full throttle and maximum permissible rpm. The descent is commenced using 87 octane fuel—i.e., a fuel of relatively low anti-knock value. As altitude is decreased the pressure and temperature of the charge air increase, until at 13,000 ft they reach the critical values for this particular type of fuel, and detonation begins. At this point the engine is developing 570 bhp.

Still more power is potentially available at a lower altitude, but at the given maximum permissible rpm this additional power is not attainable without detonation. Below 13,000 ft the engine must accordingly be operated at part throttle, and the maximum bhp that can actually be used is 570. This power is available at part throttle from 13,000 ft, the so-called full throttle, or critical altitude to sea level; above 13,000 ft altitude the 570 bhp cannot be obtained.

The fuel selector valve is now switched to a tank containing 100 octane fuel—i.e., one of high anti-knock value — and the descent continued from 13,000 ft at maximum permissible rpm and full throttle. At 10,000 ft, corresponding to a

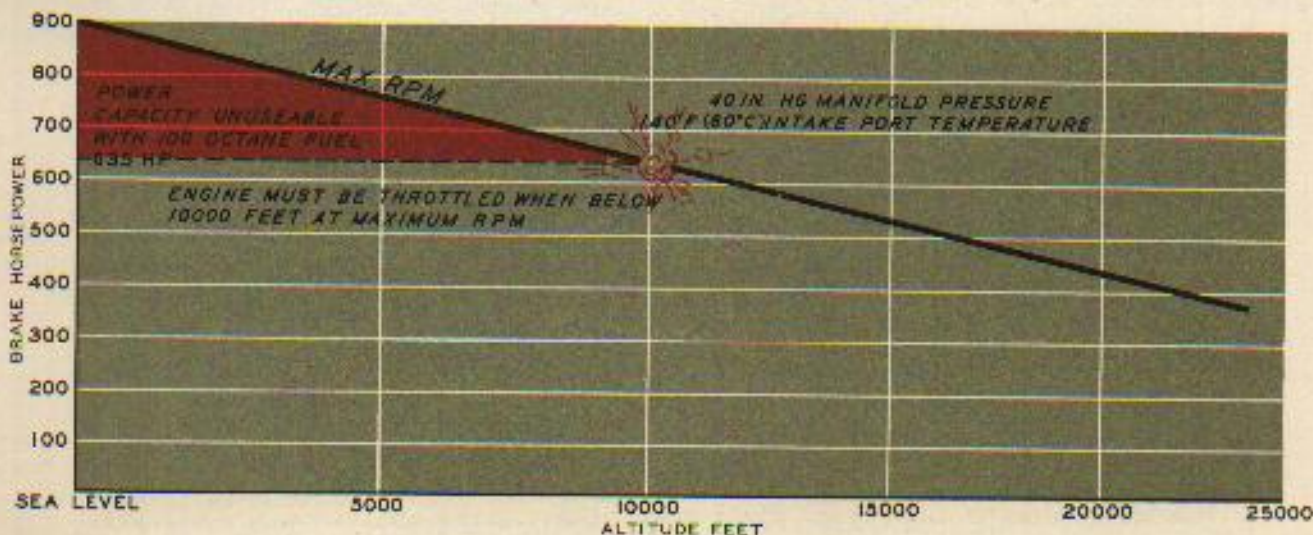

Fig. 17 — Descent Performance — 100 Octane

bhp of 635, the pressure and temperature of the charge become critical for the 100 octane fuel, and detonation again begins. With this fuel the power output must be limited to 635 bhp, and is available at part throttle, from sea level to 10,000 ft, the critical altitude.

The selector valve is now switched to a third tank containing a magic, non-detonating fuel, and the descent is continued as before. With this fuel, detonation is no longer the limiting factor. Nevertheless, at 4,000 ft there is an ugly noise and the engine fails as it is developing 790 bhp, indicating that the limit of its structural strength has been reached. This, then, is the maximum available bhp regardless of fuel quality, and 4,000 ft is the corresponding full throttle, or critical, altitude. When the engine failed at 790 bhp, an additional 90 horsepower were being absorbed by the supercharger. (Friction and other power losses are neglected.) The total of 880 horsepower is thus the ihp capacity of the engine as determined by its structural strength regardless of the degree of supercharging. The engine just described can therefore never develop the 1,000 ihp or the 900 bhp potentially available at sea level; and all operation from sea level to the critical altitude—as determined by the fuel or the engine's structural limitations—must be at part throttle. Such an engine for which full throttle operation at sea level is restricted or prohibited, is known as an "altitude" engine.

COMPARISON OF NATURALLY ASPIRATED, GROUND-BOOSTED, AND ALTITUDE ENGINES

The difference between a ground-boosted and an altitude engine is largely a matter of definition. For both normally aspirated and ground-boosted engines the maximum usable power and the engines' theoretical potential power producing capacity are the same. In the case of an altitude engine, on the other hand, the maximum usable power is less than the engine's theoretical capacity. It is also conceivable that an engine might be considered a ground-boosted engine with a high quality fuel and an altitude engine with a lower grade fuel.

The foregoing discussion dealt with three variations of the same basic engine. The power sections and rpm were assumed to be identical in each case, the only difference being in the degree of supercharging. The performance of these three engines is compared in Fig. 19. It will be noted that the ground-boosted engine, because so little of its power is directed to the supercharger, delivers more power (bhp) to the propeller shaft at sea level than the highly supercharged engine using either 87 or 100 octane fuel. The better low level performance of the ground-boosted engine is more than offset, however, by the greatly superior performance of the highly supercharged engine at altitude.

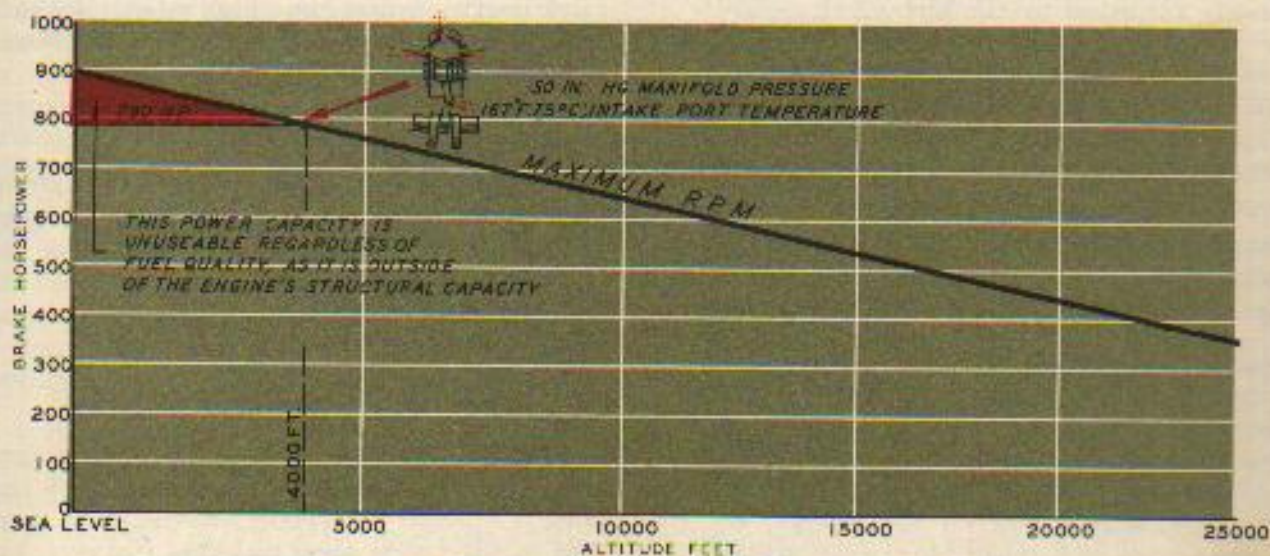

Fig. 18 — Descent Performance — Non-Detonating Fuel

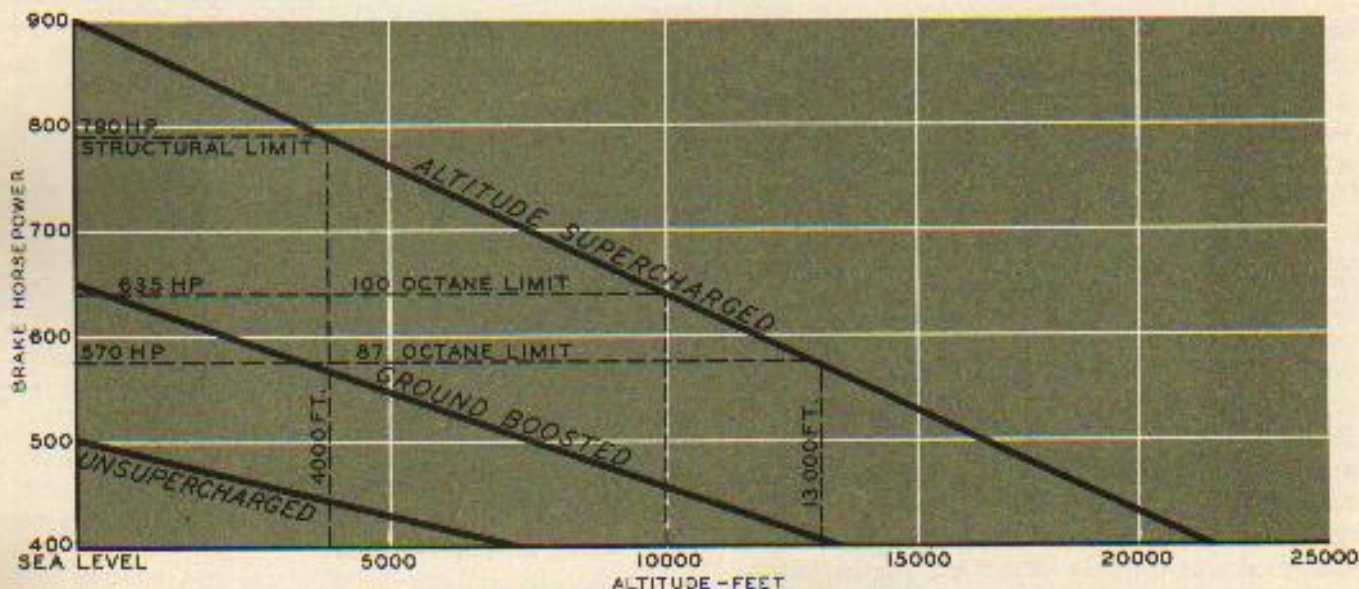

Fig. 19 — Performance Comparison — Unsupercharged, Ground Boosted and Altitude Supercharged Engines

The restriction placed on maximum power output by structural limitations should not be interpreted as a reflection on the engine. The designer's problem is to maintain some desired performance up to the highest possible altitude with the least weight and size, and with the available quality fuel. This is achieved on the highly supercharged, or altitude, engine by providing a pumping capacity that is greater than

necessary or safe to use at or near sea level in order to meet the greater pumping requirements at the higher altitudes. Since the danger exists that the operator may inadvertently make use of this excess power at low altitudes by exceeding a safe limiting manifold pressure, it is essential that he exercise both care and judgment to protect the engine against the results of unrestricted operation.

3. DUCTING

The portion of the induction system that is ahead of, or "up-stream" from, the carburetor is usually furnished by the aircraft manufacturer (as distinct from the engine manufacturer). While not part of the engine bill of materials, this ducting is an intimate portion of the induction system and exerts considerable influence on engine performance and the maintenance of proper operating conditions.

The aircraft ducting affects engine operation as follows:

RAM

Because of the forward motion of the aircraft considerable velocity energy is available in the air entering the carburetor air intake. Proper formation of the air entrance and the passages and elbows of the air duct can result in the recovery of a large portion of this energy, or ram, and air will be furnished to the carburetor at a pressure greater than that of the altitude

at which the aircraft is flying. This has the effect of increasing the supercharging capacity and, in extreme instances, high velocity aircraft can recover ram equivalent to an additional stage of supercharging.

INDUCTION SYSTEM ICE PREVENTION AND REMOVAL

To protect the engine induction system against ice formation, or to remove ice already formed, the ducting to the carburetor is arranged so that the ram air can be closed off and heated, or moisture-free air drawn in from a different source. The degree of heat required differs between engine models because of differences in the method of injecting the fuel.

The greatest preheat capacity must be furnished for installations of engines in which the fuel is injected immediately downstream from the carburetor. In these cases the fuel evaporation occurs in a region in which no heat is re-

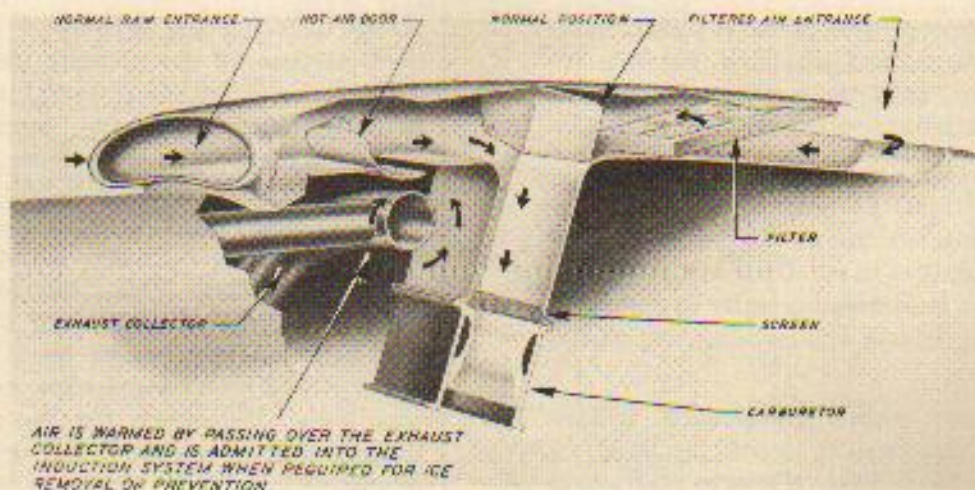

ceived from other sources and the temperature of the charge is lowered as much as 50 F (28 C) with the result that the moisture contained in the charge will freeze on any convenient surface and possibly block the passage if the carburetor air temperature is between 32 F-80 F (0 C-25C).

When the fuel is injected immediately adjacent to the face of the impeller, the mechanical action of the rotating impeller practically eliminates this possibility and it is not necessary to use the quantity of preheat for ice prevention that is required by other injection systems.

However, regardless of the type of fuel injection used, ice can be formed because of near freezing moisture in the atmosphere or because of the temperature drop past the throttle. All experience accumulated to date conclusively demonstrates that ample preheat capacity is the only sure method of providing the temperature rise needed to remove ice already formed. The so-called "alternate air systems" taking air from over the cylinders or from the accessory compartment does not provide sufficient temperature rise to give this essential protection.

DUST PROTECTION

Dust protection was not seriously considered until World War II, but large-scale operations at training bases in the United States and under combat conditions in North Africa and other theaters clearly demonstrated that when it was necessary to operate in dust-charged air, protection for the engine must be provided. While dust to most individuals is merely an

annoyance, it is a serious source of trouble to an engine. Dust consists of small particles of hard abrasive material. Taken in by the air, it can collect on the metering elements of the carburetor, upsetting the proper relation of fuel flow to power. It next asserts itself in the cylinder walls by grinding down these surfaces and the piston rings. It then contaminates the oil and is carried through the engine causing the bearings and gears to experience distress. In extreme cases an accumulation may clog an oil passage and cause oil starvation.

Whereas dust is most evident close to the ground, in certain parts of the world it can be carried to altitudes as high as 15,000 feet. Continued operation under such conditions without engine protection will result in evidence of engine wear as indicated by high oil consumption. During World War II in the North African operations, engines which had demonstrated the ability to perform satisfactorily for 600 or 700 hours between overhauls under dust-free combat conditions, could swallow dust for only 20 hours before requiring removal.

When operation in dusty atmosphere is necessary, engine protection can be obtained by means of suitably designed alternate air entrances to the induction system which incorporate a dust filter. The system shown on the title illustration is typical. As the air entrance to the filter does not face directly into the air stream, considerable dust removal results in forcing the air to turn as it enters the duct. The dust particles, being solid, tend to continue in a straight line and the greatest portion of them are removed at this point. Those that are drawn in are quite easily removed by the filter.

The efficiency of the filter depends upon proper maintenance and servicing. Periodic removal and cleaning of the filtering elements is essential to satisfactory engine protection.

Most production aircraft for civilian use do not include filters as standard equipment. Where the operations are conducted from well-established dust-free bases, the omission of the filtering system is justified in order to eliminate the appreciable weight and complication of the installation.

In those cases where the aircraft is furnished with a filter and it is possible to select either ram or filtered air, the ram position is preferred for all dust-free conditions of operation as the filtering system causes a measurable loss of ram energy in the air flowing to the engine.

SCREEN

Pratt & Whitney Aircraft furnishes, with each engine, a coarse mesh screen to be in-

stalled between the carburetor and the adjacent portion of the aircraft charge-air duct. This screen is for the essential purpose of preventing stones, nuts, bolts, papers, rags, tools or any other loose object from further penetrating the induction system and damaging the impeller. Many operators have removed these screens in order to dispose of a possible surface for ice formation. While they were successful from this point of view their experience has been an unhappy one in that the inevitable stone picked up by a propeller, or the nut that was lying loose when the air scoop was removed, chewed up the impeller and complete engine removal was necessary.

If the operating personnel can exercise the necessary precautions to prevent ice (a factor over which they have effective control) it will not be necessary to remove this protection to the engine from conditions over which they have little, if any, control. Pratt & Whitney Aircraft strongly recommends that these screens be used as intended.

THE IGNITION SYSTEM

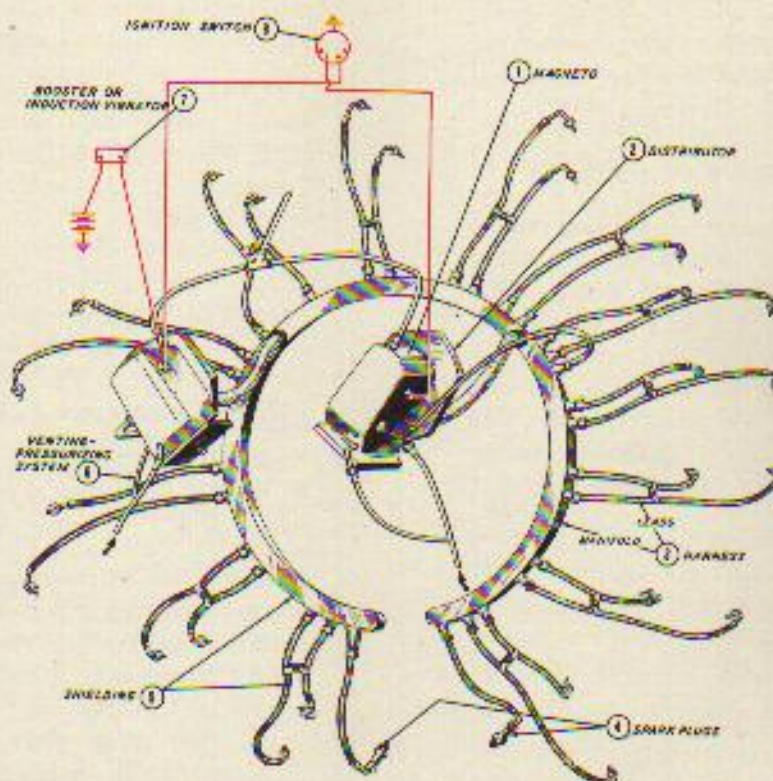

PARTS AND FUNCTIONS

The chief parts of a typical ignition system and their functions are:

1. **Magneto:** generates a current of high voltage which is discharged at the proper time.
2. **Distributor:** distributes the current to the proper spark plug.
3. **Harness:** transmits the current from the distributor to the plugs.
4. **Spark Plugs:** ignite the fuel-air charge in the cylinders.
5. **Shielding:** provides a grounded metallic enclosure for the entire ignition system to protect radio against interference from the ignition system.
6. **Venting System:** provides natural air motion or produces positive air flow to prevent contamination of the ignition system by moisture, engine oil or acids formed by electrical action.
7. **Booster or Induction Vibrator:** provides an auxiliary spark at starting only.

8. **Ignition Switch:** provides a means of turning the ignition either on or off.

For safety reasons two ignition systems are normally furnished. In the event of failure of one, the other will insure continued operation. At the same time dual ignition, as this arrangement is called, will help the combustion process by providing two flame fronts which results in more efficient burning of the charge.

CONTROL AND CHECKS

Engine performance furnishes the only clue to the functioning of the ignition system, and the pilot has no control over it other than to turn it off or to turn on either or both halves of the system.



PLUGS FIRING

Front and Rear
Rear (in each cyl)
Front (in each cyl)
None

SWITCH POSITION

Both
Left (L)
Right (R)
Off

By operating the engine at reduced power for a few seconds, first on one magneto, and then on the other, and noting its rpm with the ignition switch in the BOTH, LEFT, RIGHT and OFF positions, it may be possible to learn something about both the nature and location of an observed or suspected ignition irregularity.

IRREGULARITIES AND FAILURES

The ignition system furnished with an engine is the result of careful design and thorough proof testing. In all probability it will give dependable service provided it is properly maintained and serviced. However, irregularities can occur which will affect its performance and while these difficulties are rare, it is well to review their causes in order that the symptoms of malfunctioning can be understood.

1. Breakdown of insulating materials, burning of breaker points, short circuits or broken electrical connections are comparatively rare. They are revealed by rough running, loss of power, or possibly complete stoppage.
2. More common are irregularities due to moisture which might accumulate in different parts of the ignition system. This accumulation can be caused by breaks, or loose covers allowing direct access of water to the system. Breathing, which occurs during the readjustment of the system from low to high atmospheric pressure, can result in drawing in moisture-laden air. Ordinary condensation of moist air, as the engine cools, can also result in appreciable moisture accumulation. This moisture causes the insulating materials to lose their electrical resistance. A slight amount of moisture contamination will cause a reduction in magneto output by leaking part of the current, intended for the spark plug, to ground. This condition will first be noticed in starting difficulty, at which time the magneto output is already reduced by the low cranking speeds.

If the moisture accumulation is serious, the entire magneto output will dissipate to ground and might cause flashover and burning of insulating parts, which can result in their permanent failure.

Moisture accumulation in flight is extremely rare, as the temperature of the system is effective in preventing condensation, and difficulties from this cause will more probably be evident on the ground.

3. The normal unpressurized ignition system can operate satisfactorily as high as 25,000 feet. Above this altitude, the low electrical resistance of the reduced air density will quickly show up any irregularity that would not be serious at lower levels. As altitude is further increased, it becomes necessary to supply the system with air under pressure or to fill it completely with a nonconducting substance, in order to maintain sufficient electrical resistance to prevent flashover.
4. Probably the most commonly blamed of all causes of irregular engine operation is the **spark plug**.

This may be the result of incorrectly selected plugs, incorrect gap clearance, faulty installation, improper engine operation, carbon or lead fouling, condensation in the cylinders, or actual breakage of the plugs. On the one hand, the plugs may run so hot as to become incandescent and cause pre-ignition and tend to lead fouling; on the other, they may run so cold as to be fouled out by the accumulation of unburned carbon. Spark plug trouble is likely to be localized at one or several plugs, but the evidences of spark plug trouble are much the same as those of other types of ignition irregularities.

The cutting out of one-half of the ignition system, or the failure of a spark plug in one or more cylinders, will result in slower combustion in the cylinders affected. The effect is comparable to that of delaying the timing of the spark discharge, and the consequence is a loss of power, although rpm and manifold pressure will, as a rule, remain unchanged. If both plugs fail in one or more cylinders, the result is, essentially, an engine of fewer cylinders. In any case, the attempt to recover the lost power by increasing manifold pressure is unwise, since it may lead to detonation, especially when operating in the high power range.

PART II

POWER, BMEP, AND RATINGS

Since engine design and operation both have as their ultimate objective the efficient and reliable production of power, it may not be altogether inappropriate at this point to inject a definition of "power", together with a brief description of the methods by which it is measured and produced, and to conduct a hasty investigation of certain of the limitations to which its application is subject.

In the course of this discussion, the reader must desert the cockpit and the hangar for the laboratory of the engineer and the ivory tower of the physicist. If in these new surroundings

he encounters a few strange faces, or if the ill-laid ghosts of some happily forgotten course in elementary mechanics rise to try his patience and shatter his interest, his indulgence is craved; and it is hoped that his industrious application to the dull and difficult paragraphs that follow will be rewarded by at least a nodding acquaintance with such formidable terms as indicated horsepower, torque, brake mean effective pressure, and Normal Rated power, as well as by a better understanding of some of the problems fundamental to powerplant design and operation.

POWER AND ITS MEASUREMENT

FORCE

The definition of power involves the three basic ideas of force, distance, and time. The concepts of time and distance are deceptively elusive, and do not permit a ready definition, but their meanings will none-the-less be generally obvious. Force masquerades in a variety of disguises — mechanical, electrical, chemical — but it is anything which tends to produce, inhibit, or alter motion, such as a pressure, a weight, a tension. Motion is not necessarily implied, since two or more forces acting simultaneously on a body may be so balanced as to render the body immobile.

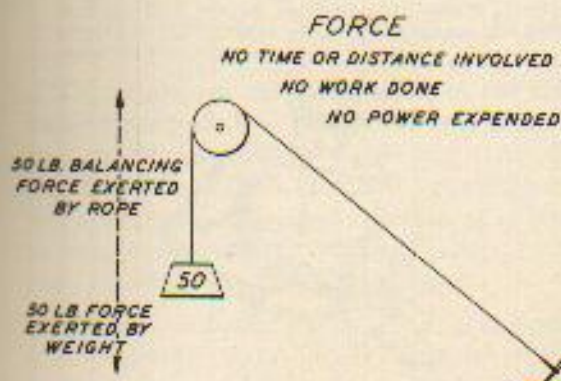

WORK (FORCE \times DISTANCE)

To many individuals, work is the effort expended (if any) between "punching the clock" in the morning and "ringing out" at night, and is measured in terms of fatigue, boredom, or dollars and cents. The engineer's definition, while lacking in human interest, is somewhat more precise. For him, work is the product of a force and the distance through which it acts, or:

Work = Force \times Distance (in the direction of the force)

For example: If a weight of 50 lb is raised a distance of 11 ft, the work done is: 50 lb \times 11 ft = 550 ft-lb. The same amount of work, 550 ft-lb, will be done if a 10 lb weight is raised 55 ft.

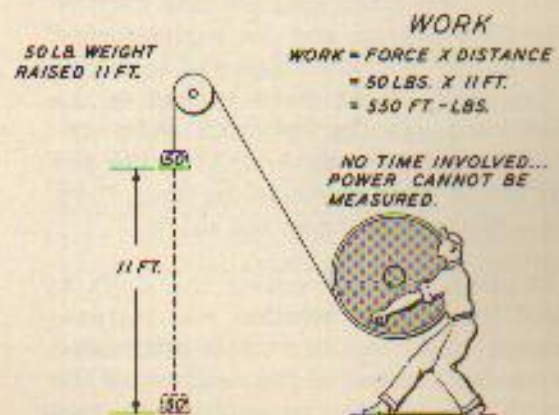

POWER (WORK ÷ TIME)

Power may be "juice" or "soup" to the layman, but to the initiated, it is the rate of doing work — in other words, the amount of work done in a certain length of time.

Thus: Power = Work/Time

If the reader climbs 4 flights of stairs, the work done — i.e., the product of his weight by the total height of the stairs — will be the same regardless of the rate of ascent. On the other hand, if the reader first saunters slowly up the 4 flights and a little later, being sound in wind and limb, runs up them in, say, one-third of his original climbing time, pulse and perspiration should convince him that he develops considerably more power during the rapid ascent than during the leisurely climb.

Power is expressed in a number of units — horsepower, kilowatts, Btu per minute, cheval-vapeur, etc. — of which the first named is perhaps the most familiar. One horsepower (hp) is defined as work done at the rate of 550 ft-lb per second, or, what is the same thing, 33,000 ft-lb per minute.

(1) Horsepower =

$$\frac{\text{No. ft-lb per sec.}}{550} = \frac{\text{No. ft-lb per min.}}{33,000}$$

Thus, if an engine is doing work at the rate of 16,500 ft-lb per sec, or 990,00 ft-lb per min; it is developing 30 hp.

TORQUE (FORCE × DISTANCE AT RIGHT ANGLES)

So far, the discussion of Work ÷ Time considers that the force factor of work is acting only in a straight line. The form of power existing in a rotating shaft does not lend itself to this elementary concept and the analysis must go further so that the performance of an engine can be described. If the force applied to the crank shaft through the link rods were considered as being constantly exerted at the end of a lever and at right angles to the lever, there would be a tendency to twist the shaft.

This twisting tendency causes the shaft to rotate and the rate of rotation will increase until an equal and opposite force is established in the propeller because of the reaction of the blades with the air. If this equilibrium condition is at 2000 rpm, the power formula could be worked as follows:

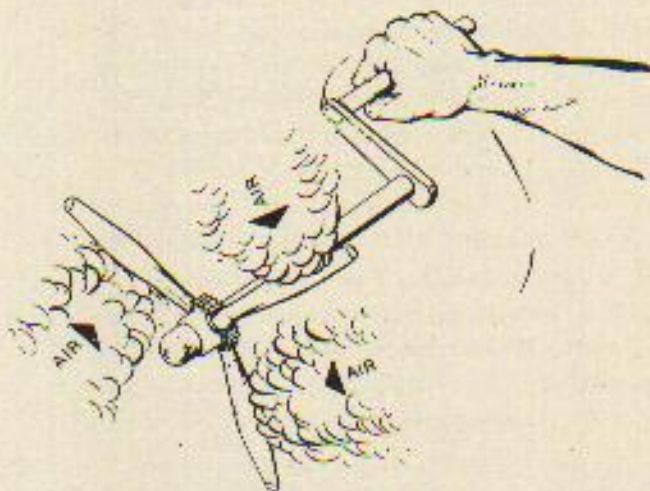
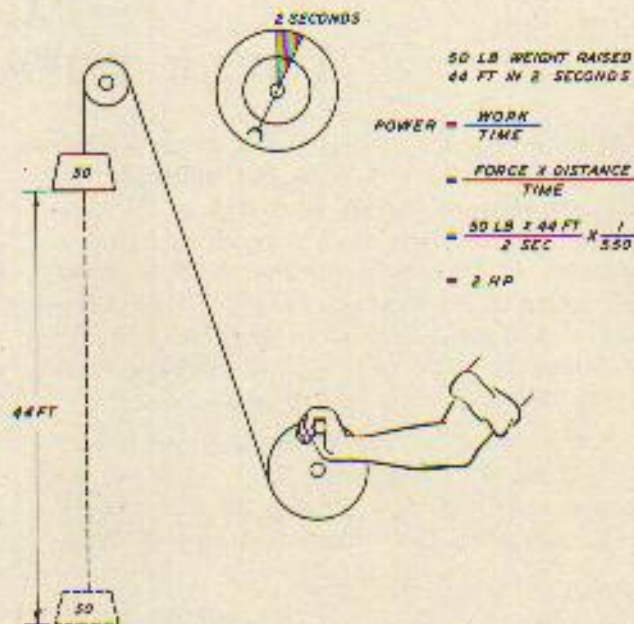

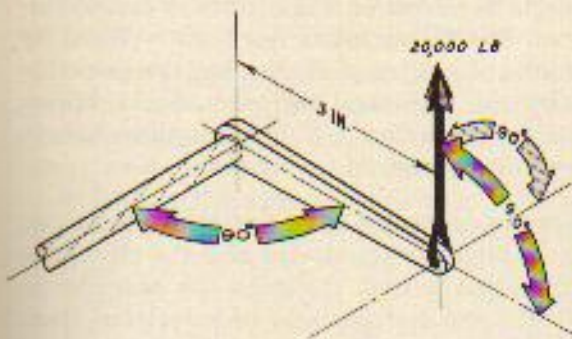

Force = 20,000 lb

$$\begin{aligned} \text{Distance/Min} &= 2\pi \times \text{radius} \times \text{rpm} \\ &= 2\pi \times 3/12 \text{ ft} \times 2000 \\ &= 3142 \text{ ft/min} \end{aligned}$$

$$\begin{aligned} \text{And (1) HP} &= \frac{\text{Ft-lb per min.}}{33,000} \\ &= \frac{20,000 \text{ lb} \times 3142 \text{ ft}}{33,000} = 1904 \end{aligned}$$

The twisting force existing in the shaft as the result of applying the 20,000 lb load at the end of the 3 in. lever is known as torque. Those who have hand-cranked automobiles or out-board motors have applied torque by exerting push or pull at right angles to a lever attached to a rotating shaft and

$$\text{Torque} = \text{Force} \times \text{Distance} = \text{lb-ft.}$$

where the distance is measured in a plane which is at a right angle to the center line of the shaft and the force is at a right angle to the distance.

In the example cited above, the torque is equal to 20,000 lb \times .25 ft or 5000 lb-ft. It should be noted that 5000 lb-ft of torque would be obtained if a 1000 lb force were applied with a 5 ft arm or a 40,000 lb force were applied with an arm of 1 1/4 inches. The torque force in the shaft is the same provided the product of the force times the lever arm remains the same.

Therefore, the torque present in the shaft is independent of its diameter. It is a measure of load and is properly, though not consistently, expressed in lb-ft. It is not to be confused with work which is expressed in ft-lb. It is possible to have torque (lb-ft) without motion in which case no work (ft-lb) is performed.

Plunging headlong into the mathematics of a horsepower, equation (1) can be reworked so that the useful engine output can be expressed in terms of rpm and torque.

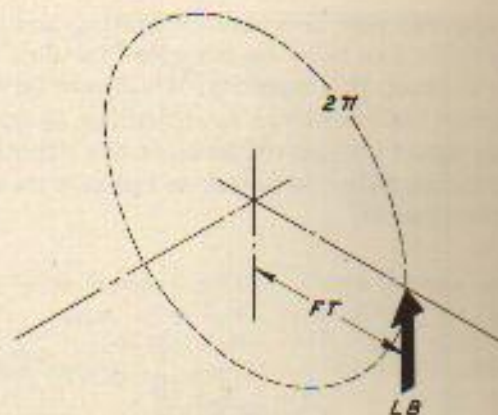

$$\text{LB} \times \text{FT} = \text{TORQUE}$$

$$2\pi \times \text{TORQUE} = \text{WORK IN ONE REVOLUTION}$$

$$2\pi \times \text{TORQUE} \times \text{RPM} = \text{WORK IN ONE MINUTE}$$

$$(1) \text{ HP} = \frac{\text{ft-lb}}{\text{min.}} \times \frac{1}{33,000}$$

Now torque is defined as lb-ft and so contains a force value and also a distance value. To obtain ft-lb/min., it is necessary to include 2π because of circular motion and rpm to represent the number of circles traveled in a given time.

Therefore,

$$\text{HP} = \frac{\text{ft-lb}}{\text{min.}} \times \frac{1}{33,000}$$

$$= \text{Torque (lb-ft)} \times 2\pi \times \text{rpm} \times \frac{1}{33,000}$$

$$(2) = \frac{\text{Torque} \times \text{rpm}}{5252}$$

if torque is expressed in lb-ft or

$$(2a) = \frac{\text{Torque} \times \text{rpm}}{63,025}$$

if torque is expressed in lb-in.

Equations (2) and (2a) are rational. They apply to the power present in any rotating shaft regardless of the kind of power producing unit that is causing the shaft to rotate. To measure and control the power delivered by the shaft, it is only necessary to have means for measuring and controlling rpm and torque. The more directly these two factors are measured, the greater the accuracy of the power determined.

The tachometer measures rpm directly. The tachometer generator is geared to the crankshaft gear train and the only inaccuracies are those of instrument calibration.

Torque has been less accommodating and for years, there has been no tangible "handle" by which to grasp this quantity. If a direct torque measuring instrument is not provided, there is then no direct cockpit evidence of the situation and it is necessary to resort to indirect means of measurement.

force required to restrain the brake from turning could be measured and the power output calculated. The Prony brake has been replaced by hydraulic or electrical devices but the principle remains the same and the term, brake horsepower, refers to that part of the engine's output that can be measured by a brake.

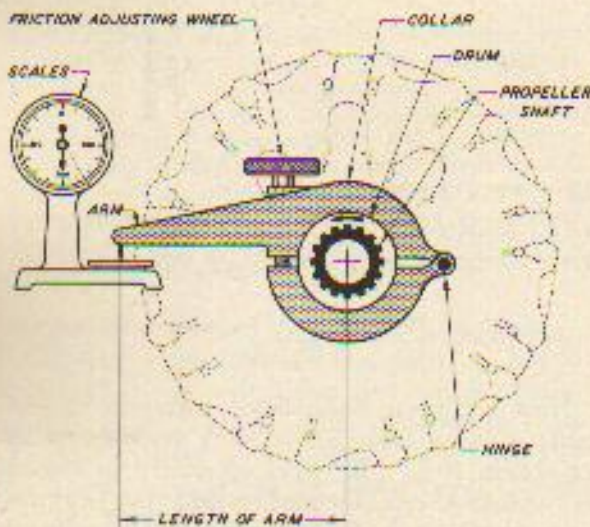

A brake cannot be used for power measurement in flight as the device absorbs all of the useful engine output. Actually, the propeller is the brake and torque could be calculated from consideration of blade characteristics provided that blade angle, air density and airspeed were accurately accounted for. However, this would be an indirect measure of torque.

In the laboratory, torque is measured by the device used to absorb the engine's power output. The earliest method employed was the Prony brake which regulated the rpm and torque load by means of a brake or friction device. The

On aircraft equipped with fixed pitch propeller blades, rpm and torque are inseparable. Advancing the throttle lever admits more air and fuel mixture into the cylinder. The combustion force is increased and as a consequence, the torque imposed on the crankshaft is increased. The crankshaft attempts to avoid this additional load by turning faster but in so doing defeats itself by turning the propeller faster. When the added torque absorbed by the propeller matches that produced by the cylinders, equilibrium is reached at a higher rpm and torque. The operator of this equipment only sees rpm and so can be excused if he is unaware of

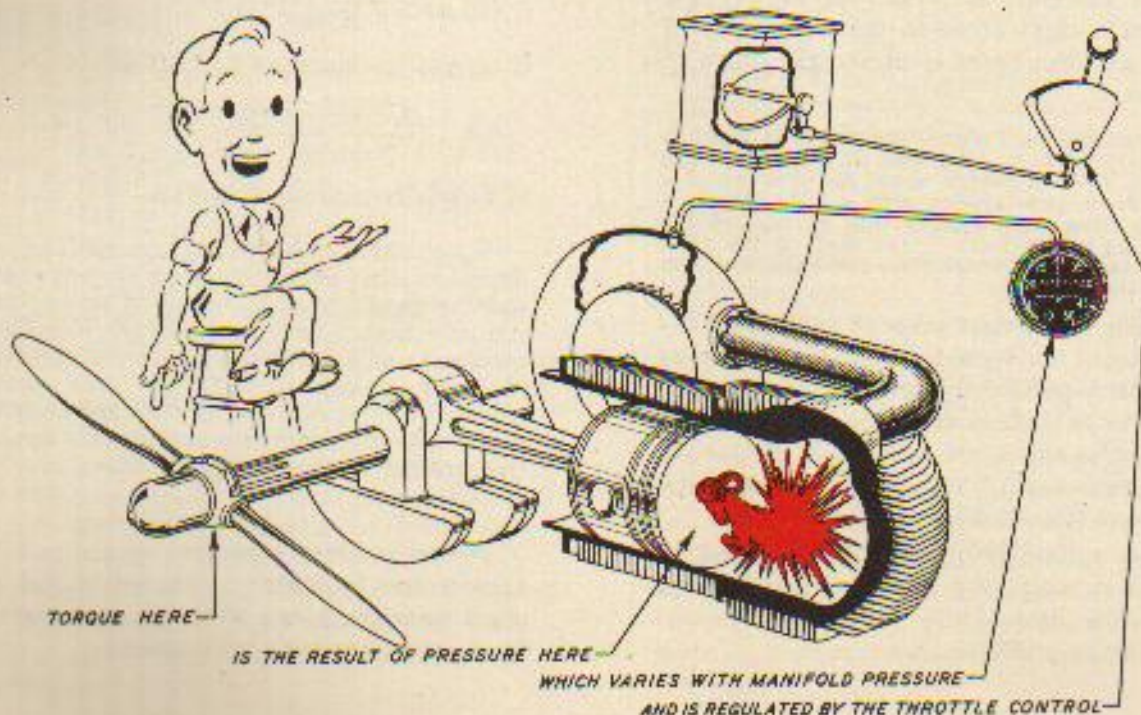

torque. The fact that, at constant rpm, torque changes with airspeed, altitude and air temperature cannot be of any great concern.

The operating significance of the constant-speed propeller is that rpm and torque are separately controlled. The tachometer then becomes solely a measure of the rpm which is controlled by the rpm control. The throttle is separated from rpm and applies its entire attention to the regulation of torque in company with the supercharger control, the mixture lever, preheat regulator and the airplane control column as it varies altitude.

Lacking a direct measurement, the regulation of torque has been by reference to manifold pressure. The relationship of this quantity to torque is determined on the dynamometer where both are measured and information compiled so that acceptably accurate flight control is possible. The relation varies with changes of rpm, altitude, carburetor air temperature, humidity, exhaust back pressure, fuel-air ratio, spark advance, supercharging and engine condition. The accuracy of using manifold pressure in place of a direct torque measure depends on the completeness of correcting for variations of these factors.

More recently, torquemeters have been made available on the larger engines and a direct cockpit indication of torque is available.

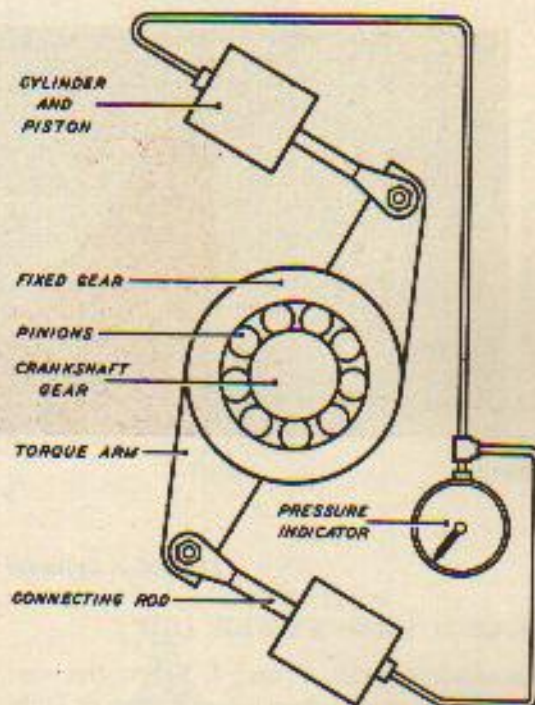

Equation (2) then becomes

$$3) \text{ BHP} = \text{torquemeter oil pressure} \times \text{rpm} \times K$$

where torquemeter oil pressure is indicated in the cockpit and K is a constant determined for each torquemeter design.

BRAKE MEAN EFFECTIVE PRESSURE (BMEP)

One of the basic limitations placed on engine operation is imposed by the pressures developed in the cylinders during combustion. On the one hand, as these pressures become greater, the result is an increase in power; on the other, if they become too great, they impose high continuous loads which shorten engine life. It is important, then, that the operator have at his disposal some means of estimating these pressures, not only to enable him to protect his powerplant but also to direct him in the efficient application of its power.

Cylinder pressures are not recorded on any cockpit instrument or gage, and their direct measurement is actually very difficult. They are related to manifold pressure, since any increase in the latter results in a heavier weight of the charge being forced into the cylinders, and consequently, a greater amount of energy being

liberated by combustion. However, a number of other factors must be taken into account, notably temperature and fuel-air ratio, and, at best, manifold pressure is merely a qualitative measurement. A convenient way of estimating cylinder pressures proves to be an indirect one, and an index of measurement, inherited from steam engine practice, is the brake mean effective pressure, or bmep — a term that is glibly bandied about more frequently, perhaps, than it is understood.

CYLINDER PRESSURES

A series of complicated and elaborate measurements indicate that the pressures actually existing in a cylinder of an aircraft engine during a complete power cycle can be represented by a graph similar to Figure 20.

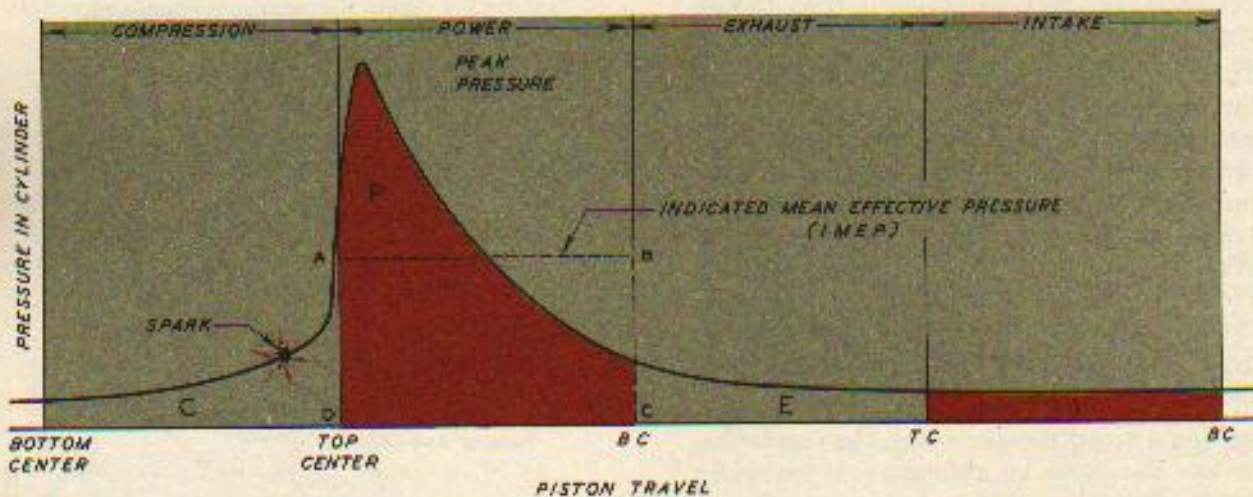

Fig. 20 - Cylinder Pressures During Power Cycle

INDICATED HORSEPOWER (IHP)

The shaded areas, P and I, below the curve represent the power developed in the cylinder; P, by the combustion of the fuel-air mixture; I, by the pressure of the incoming charge. The unshaded areas, C and E, represent the power expended: C, in compressing the charge; E, in expelling the exhaust. The net useful power, or indicated horsepower (ihp), developed may thus be represented by the difference between the shaded and unshaded areas, or:

$$\text{Ihp} = \text{Shaded Areas (P + I)} - \text{Unshaded Areas (C + E)}$$

INDICATED MEAN EFFECTIVE PRESSURE (IMEP) AND ACTUAL PRESSURES

It is sometimes convenient to think of the various cylinder pressures—useful and adverse—as combined into a single uniform pressure which acts during the power stroke alone, and is capable of producing the given indicated horsepower (ihp). This may be illustrated graphically by drawing a constant pressure line, AB, for the power stroke alone at such a distance above the horizontal axis that the area enclosed by the rectangle, ABCD, is equal to the net area representing the ihp, thus:

$$\text{Area ABCD} = \text{Shaded Areas (P + I)} - \text{Unshaded Area (C + E)} = \text{Ihp.}$$

The mean, or average, pressure (AD or BD) effective during the power stroke is known as the indicated mean effective pressure (imep).

The operator is naturally more concerned with actual shape and peak pressure of the

curve than with the abstract notion of indicated mean effective pressure (imep). For instance, a curve which rises steeply to an exaggeratedly high peak and descends thence in rapid oscillations, while it may enclose substantially the same "power area" as a smoother, flatter curve, indicates that the power of combustion is being delivered in such a way that it cannot be readily absorbed by the engine, and may prove harmful to the engine. The detonation curve below is an example.

The relationship between imep and the actual shape of the pressure curve has been established by experiment. Accordingly, if the imep of an engine can be measured significant peak pressures and other combustion characteristics revealed by the curve can be predicted with sufficient accuracy for practical purposes.

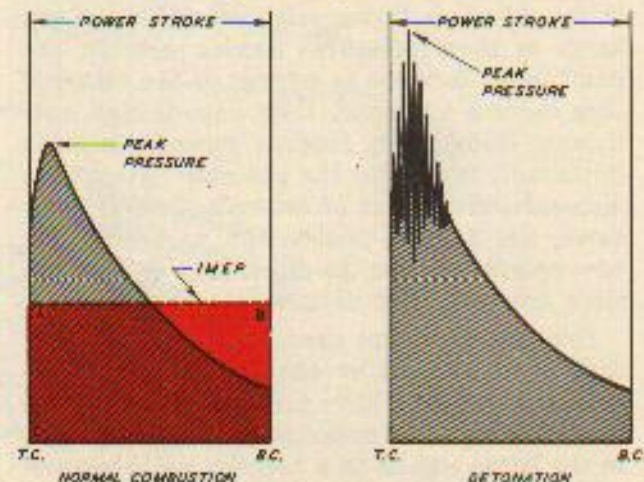

Fig. 21 - Cylinder Pressures Normal and Detonating

CALCULATION OF IMEP

If the indicated horsepower of an engine is known, its imep can be computed from the formula:

$$(4) \quad \text{Imep (psi)} = \frac{792,000}{\text{Displacement}} \times \frac{\text{ihp}}{\text{rpm}}$$

The derivation of this formula is briefly as follows:

The force, in lb, exerted in any cylinder is the product of the imep (in psi) by the area (in sq in.) of the piston head on which it acts, or:

$$F \text{ (lb)} = \text{imep (psi)} \times A \text{ (sq in.)}$$

The distance, in feet through which this force moves during the power stroke is the length of the stroke (in in.) divided by 12, or:

$$D \text{ (ft)} = S \text{ (in.)} / 12$$

The work, in ft-lb, done during the power stroke is thus:

$$\text{Work (ft-lb)} = F \times D = \text{imep} \times A \times S / 12$$

If the engine has N cylinders, the work done per revolution of the engine is:

$$\text{Work per rev.} = \frac{\text{imep} \times A \times S \times N}{12 \times 2}$$

(N is divided by 2 since each cylinder fires every other revolution.) This displacement, in cu in., of an engine is the product of the area of the piston (A) times the stroke (S) times the number of cylinders (N). Accordingly:

$$\text{Work per rev.} = \frac{\text{imep} \times \text{Displacement}}{24}$$

The work per minute is the work per revolution times the rpm, or:

$$\text{Work per min.} = \frac{\text{imep} \times \text{Displacement} \times \text{rpm}}{24}$$

Dividing the work (still in ft-lb) per minute by 33,000, results in the ihp, so:

$$\text{ihp} = \frac{\text{imep} \times \text{Displacement} \times \text{rpm}}{24 \times 33,000}$$

Transposing the known quantities to one side of the equation:

$$\text{Imep} = \frac{792,000}{\text{Displacement}} \times \frac{\text{ihp}}{\text{rpm}}$$

And, unless an engine sloughs off a cylinder, its displacement remains constant and the formula reduces to:

$$\text{Imep (psi)} = \frac{\text{ihp}}{\text{rpm}} \times (\text{a constant})$$

This would be a satisfactory way of computing imep, and thus predicting actual cylinder pressures, were it not for the fact that ihp is difficult to measure directly.

CALCULATION OF IHP (IHP - BHP = FHP)

Not all the power developed in the cylinders (*i.e.*, the ihp) is available at the propeller shaft.

As suggested in Figure 22, some of it is lost in overcoming internal friction, some is diverted to driving the accessories, such as the magnetos and fuel pumps, some is absorbed in driving the supercharging mechanism.

The total power thus lost is known as friction horsepower (fhp). What remains in the form of useful power delivered outside the engine to the propeller shaft and other shafts is called brake horsepower (bhp).

$$\text{Ihp} = \text{bhp} + \text{fhp}$$

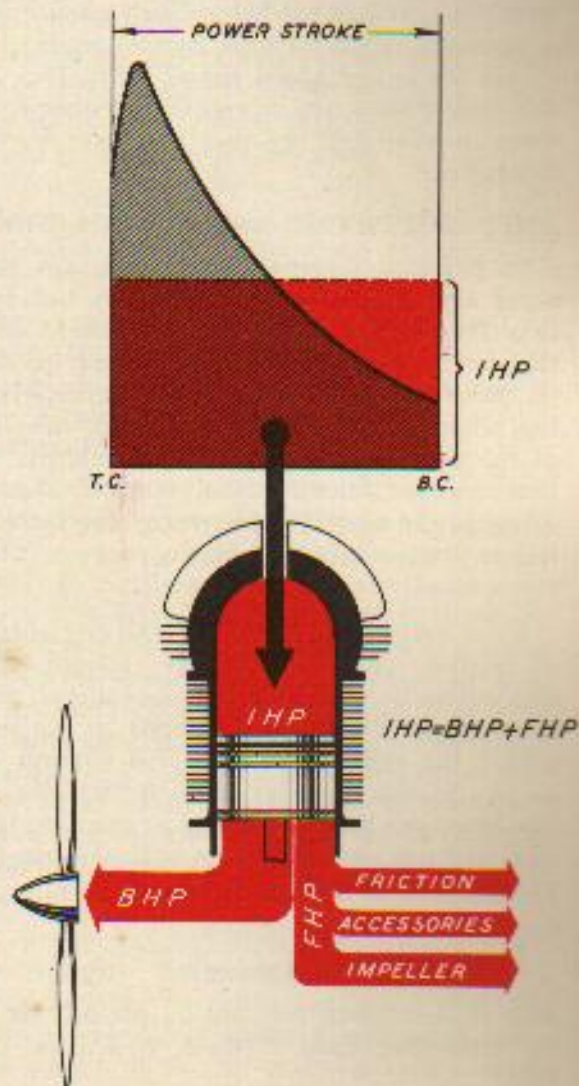

Fig. 22 - Powers and Pressures

This relationship makes possible a sufficiently accurate and relatively simple computation of ihp, and suggests a short-cut to the determination of cylinder pressures. Bhp can be readily calculated by means of a Prony brake, a dynamometer, or torque meter. In fact, whenever the relation between bhp, rpm, and manifold pressure has been calibrated for a given engine, the bhp may be found from a power curve, if the last two quantities are known and the proper corrections made for carburetor air temperature and other items. Friction horsepower (fhp) is not a constant quantity, but increases with the rpm and impeller speed or stage of supercharging. It can be determined for any given rpm and supercharging combination by measuring, on a modified dynamometer, the power necessary to turn over the engine with the cylinders not firing. Such a calibration is normally made for each type of engine, and covers its entire speed range. With bhp and fhp thus known, ihp is readily calculated, and from it, imep and cylinder pressures may be determined.

BMEP—DEFINITION AND COMPUTATION

In practice, however, actual cylinder pressures are not determined from ihp, but from bhp. By analogy, imep can be thought of as the sum of two pressures; one going to produce the power necessary to overcome friction (fhp), the other to produce the net power delivered at the propeller and other shafts (bhp). The first is called friction mean effective pressure (fmep); the second is known by the more familiar, but no less formidable, name of brake mean effective pressure (bmep).

Since neither bhp or bmep take any account of friction, the engine can be thought of, in this connection, as a frictionless power plant in which all the power developed by the bmep within the cylinders is delivered without loss as bhp to the propeller. Substituting bhp for ihp, bmep can be computed by an equation identical in form and derivation with the one previously used to compute imep, namely:

$$\text{Bmep (psi)} = \frac{792,000}{\text{Displacement}} \times \frac{\text{bhp}}{\text{rpm}}$$

and, if this bmep formula be divided by the corresponding imep formula, it will be seen that:

$$\frac{\text{bmep}}{\text{imep}} = \frac{\text{bhp}}{\text{ihp}}$$

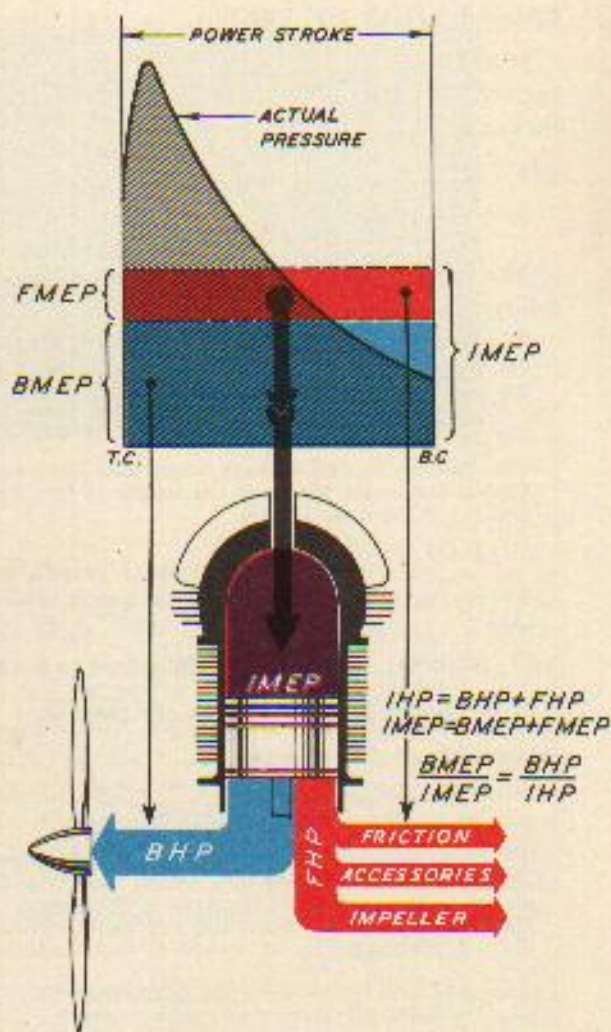

Fig. 23 — Powers and Pressures

Bmep, therefore, proves to be something of an abstraction—a fictitious pressure which has no real existence in the cylinders. Imep is clearly greater than bmep, since it comprises both bmep and fmep. (Depending largely on the rpm, bmep may be from 10 to 50 psi less than imep, and may represent as little as 85% of the latter.) Furthermore, the actual peak pressure, as shown on cylinder pressure curves, are in turn greater than the imep. Nevertheless, this abstraction proves to be a useful one in estimating the actual pressures and in establishing operating limits.

BMEP AND INDEX OF CYLINDER PRESSURES

To begin with, bmep may be readily calculated at any stage of operation in terms of three quantities that are easily found: bhp

(from a power curve, torquemeter, Prony brake, or dynamometer) rpm (from a tachometer), and a constant (792,000/Displacement). Moreover bmep bears a definite relationship to imep ($\text{bmep}/\text{imep} = \text{bhp}/\text{ihp}$), which is established throughout the engine's operating range by the calibration of the fhp ($\text{ihp} = \text{bhp} + \text{fhp}$). Since the actual cylinder pressures and other combustion characteristics can be deduced from imep, and since the relation of bmep to imep is known, it follows that these pressures and other conditions can be determined from bmep as well as from imep, and the fact that bmep can be more readily computed suggests its use as being a more convenient index by which to rate or limit an engine's performance.

Since a rise in bmep will normally mean an increase in the actual cylinder pressures, structural considerations will dictate that operation be confined below certain bmep values, or the stresses imposed may result in service difficulties. Bmep limits will not necessarily be the same throughout the engine's operating range, for it is the imep, not the bmep, that actually imposes the mechanical stresses and high temperatures.

BMEP AND TORQUE

Since

$$\text{bhp} = \frac{\text{rpm} \times \text{Displacement} \times \text{bmep}}{792,000}$$

and $\text{bhp} = \text{rpm} \times \text{torquemeter pressure} \times K$

$$\frac{\text{rpm} \times \text{Displ.} \times \text{bmep}}{792,000} = \text{rpm} \times K \times \text{torquemeter pressure}$$

(5) and $\text{bmep} = \text{torquemeter pressure} \times K'$ where K' is a constant which is the product of 792,000 times the torquemeter constant (K) divided by the engine displacement.

This relationship indicates that torque, which is directly measurable, is inseparably related to bmep which, being a fictitious pressure cannot be measured directly. Regardless of the term used to describe output and the limits of operation, the means of measurement and control eventually boil down to rpm and torque.

It has been shown that rpm and torque are independently controlled and that the operator has a wide variety of rpm-torque combinations to choose from to obtain the required power as in the following table using Wasp Major (R-4360) as an example.

PROPELLER		TORQUE	
BHP	RPM	LB-FT	BMEP
1800	1500	6300	218.
1800	1800	5252	182.
1800	2100	4500	156.
1800	2400	3940	136.
1800	2700	3500	121.

A theoretical approach without looking at all of the factors would favor the very minimum rpm and a correspondingly high torque or bmep, because this combination would produce the required output and deliver it to the propeller with the least ihp.

Because fuel consumption is the result of indicated horsepower, range should increase if a given value of output is obtained with the minimum rpm and maximum torque or bmep.

Practical considerations require a modification of the theory. The high propeller blade angle required to absorb such a heavy torque loading at low rpm would result in a serious loss of propulsive efficiency. While the engine would be giving its output at a very low fuel consumption, the propeller could not translate this into the most miles per pound.

The continuous high torque would result in high sustained stresses on the power transmission system from the piston to the propeller shaft. Experience over the years has proved that these loads must be limited.

To avoid flogging a laboring engine, the operator may turn to the other extreme of high rpm and low torque — only to run into another set of difficulties. Higher rpm results in greater fhp. Accordingly if 1800 bhp must be maintained, the ihp must be increased and as a result the fuel consumption will be greater as it is ihp, not bhp, that governs fuel flow. High rpm also leads to greater reciprocating loads, and the more rapidly the engine turns over (other things being equal), the sooner it will wear itself out. At the same time, the higher impeller speeds may mean that critical charge temperatures are being approached.

Proper operation clearly lies somewhere between the two extremes. Long experience of testing and service operation prove that the engine can be safely operated with good durability standards in the cruising range, using fuel of the proper grade, for prolonged periods with the cylinder pressures and temperatures represented by the maximum cruise bmep limit

specified by the engine manufacturer for the particular engine model in question.

It must be emphasized that cruise bmep limits are merely convenient numbers that describe operating limitations in terms that can be applied in the cockpit by means of available information. They do not define a knife-edge line on one side of which is safe operation while on the other side immediate destruction will be encountered. The maximum limiting cruise bmep is carefully selected on the basis of experience and test as the operating condition combining desired performance while obtaining long service life. Continuous use of excessive power, rpm, or temperature will more probably cause immediate difficulty than high bmep.

USE OF PROPELLER FOR ENGINE CHECK ON THE GROUND

In the air, the propeller converts engine output, in the form of rpm and torque, into thrust. On the ground, with no forward motion, the propeller has nothing to do but serve as a brake to absorb whatever power the engine is producing. While the efficiency of performing this function is of no concern, the propeller characteristics are of value because the torque required to obtain a given rpm is predictable as long as the blade angle is fixed.

On the ground, with the propeller adjusted to full increased rpm, the blades are positioned at a definite minimum angle. This angle will be the same each time that the propeller control is in this position. When the blades are in fixed low pitch, the engine is driving a fixed-pitch propeller and the relationship between engine performance and propeller rpm gives significant information regarding the condition of the engine. This characteristic is used during the ground check of the powerplant.

The load provided by the propeller is the result of the resistance of the air to the motion of the blades. If it is imagined that the total air force is acting at one point on the blade, the air force per blade multiplied by the distance between the point of application and the propeller center line times the number of blades equals the torque absorbed by the propeller and equals the torque output of the engine propeller shaft.

The drag force of any airfoil can be expressed by the following equation:

$$D = \frac{\rho}{2} C_d A V^2 \quad \text{where } D = \text{drag} - \text{lb}$$

C_d = constant whose value depends upon airfoil section and angle

ρ = air density

A = Area

V = Velocity

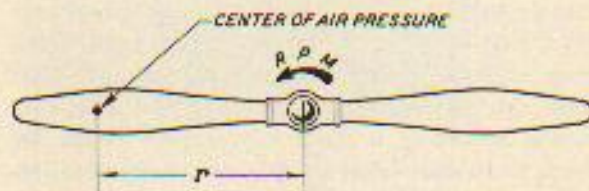

If a picture is formed of all the area and all the drag force being concentrated at one point of application, an analogous equation can be devised to describe the propeller reaction and it will not be necessary to struggle with the difference in speeds between the tip and the root; in which case,

$$F \text{ (Force against propeller)} =$$

$$\frac{\rho}{2} C_d A (2\pi r \times \text{rpm})^2 N$$

where C_d = constant, describing propeller blade characteristics at fixed low pitch

A = blade area

r = distance from engine center line to point of force application

N = No. of blades

Therefore torque varies directly as the square of the rpm. In simpler terms, if while the aircraft is static on the ground and the propeller blades are in fixed low pitch, the rpm is doubled, the torque produced and absorbed is multiplied by four. This relationship makes it possible to use the propeller to provide a brake measurement; however, the blade angle must be the same each time that the measurement is performed as the blade angle determines the value of C_d in the equation above.

From the above equation, it is no effort to continue to

$$\begin{aligned} \text{HP} &= \frac{\text{torque} \times \text{rpm}}{5252} \\ &= C' (\text{rpm})^2 \times \text{rpm} \\ &= C' (\text{rpm})^3 \end{aligned}$$

or the power absorbed by a propeller whose blades are in fixed low pitch varies as the cube of the rpm — a relation which holds true until the tip speed of the propeller approaches the speed of sound and C_d is altered. In less technical terms, this means that the power must be eight times as great to double the rpm, and twenty-seven times as great to triple it, and so on. For example, on a Wasp Major (R-4360), the following relationships of rpm, torque and power would be encountered.

ENGINE RPM	PROPELLER RPM	CRANK-SHAFT TORQUE LB-FT	PROP-SHAFT TORQUE LB-FT	POWER AB-SORBED BY PROPELLER
1000	375	840	2242	160
1500	562	1890	5040	540
2000	750	3360	8960	1280
2500	937	5252	14000	2500
3000	1125	7560	20178	4320

The figures apply, of course, to only one particular blade setting of a particular propeller. Larger propellers at the same blade angle will require more horsepower for any given rpm but equal horsepower at some lower blade angle. Smaller propellers will require high blade angles or less power. Nevertheless, the relation between rpm and bhp for any propeller and a

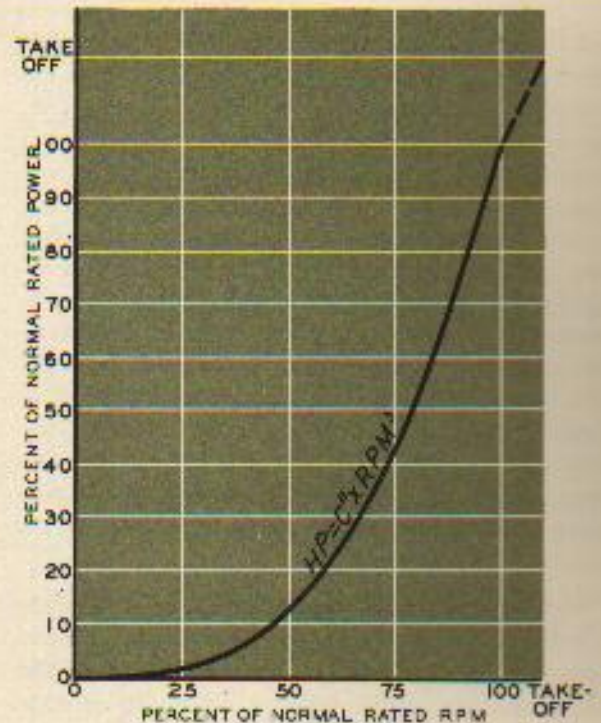
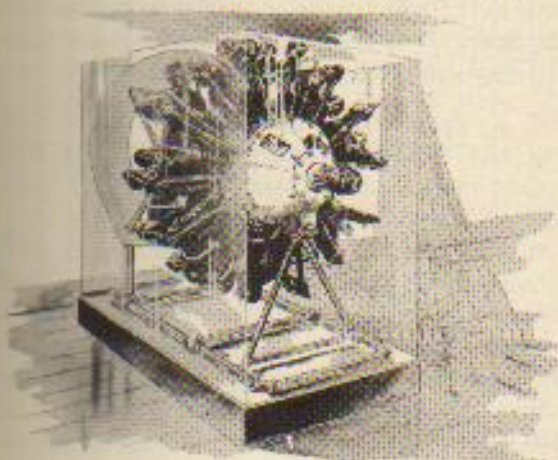

Fig. 24 — Propeller Load Curve

given blade setting will in all cases be given by formula (7).

This relation is known as propeller load and in graphical form is known as propeller load curve.

RATINGS



NEED FOR OPERATING LIMITS

An engine may be made to last forever. By "pickling" it in a suitable preservative, encasing it in a proper container, and storing it in a controlled atmosphere, it should be in as good condition after several years as at the beginning of storage. However, to serve a useful purpose the engine must be run, and in being run it is subject to wear which will inevitably limit its life span.

The previous discussion has dealt with the various forces set up in the engine in the process of producing power. As the throttle control lever is advanced cylinder pressures increase,

and the stresses resulting from these pressures become greater. Obviously there is a limit to the pressure stress that can be safely imposed on the cylinders, pistons, link rods, bearings, and other engine parts. Similarly, the control of engine speed through the propeller governor must be held within definite limits to prevent the setting up of excessive centrifugal and reciprocating forces. In addition to mechanical stresses, detonation may be the deciding factor in establishing a specific limit to either pressure or rpm with a certain grade of fuel. Once the limiting pressure and rpm have been established the limiting power is automatically defined. Engine operation is further restricted by limits imposed on cylinder and oil temperatures, and on oil and fuel pressures.

The limits of operation within which the accepted degree of reliability can be obtained are known as engine ratings. Operation within the ratings assures dependability, as amply demonstrated by the type or proof tests required by the procuring or regulating agency. Operation outside of these limits cannot assure this reliability, and the pilot is relying on margins of safety that have not been proved.

As reliability occupies a place of the greatest importance, and as the ratings define the upper limits of reliable performance, they are a logical beginning for a discussion of engine operation.

The ratings of a particular engine are to be found in the engine specifications and in the specific operating instructions, and in addition, are indicated on the applicable operating curves. Referring, for example, to the Specific Operating Instructions for a Double Wasp CA15 single-stage, two-speed engine, the ratings will be obtained from the pilot's check chart as follows:

Rating	OPERATING CONDITION		ENGINE SETTING			Max. Pressure In. Hg
	Bhp	Critical Air-Intake Feet	Impeller Ratio	Mixture Control Position	Engine Rpm	
Take-off (5 min. with water)	2400	1000	Low	Auto Rich	2500	50.5
Take-off (5 min. without water)	2100	3500	Low	Auto Rich	2500	51.5
Maximum Continuous Power	1900	4700	Low	Auto Rich	2600	46.5
Normal Rated Power	1600	14200	High	Auto Rich	2600	45.0
Normal Rated Power	1400	5500	Low	Auto Rich	2600	44.0
Normal Rated Power	1600	14200	High	Auto Rich	2600	45.0

Maximum Cruise Power: Maximum Cruise power shall be approved in writing after consultation with Pratt & Whitney Aircraft. The use of lean mixture for Continuous Cruise shall be reserved for conditions of operation permitting the maintenance of maximum head temperatures of less than 430 F and oil inlet temperatures of less than 185 F. The use of high impeller ratio shall not be attempted if the carburetor air temperature exceeds 60 F.

MAXIMUM CONTINUOUS RATING

The rating defining the maximum power available for continuous operation is Maximum Continuous power. This rating is to be used for emergency flight conditions requiring maximum sustained output. Automatic rich mixture, or its equivalent, is required when using Maximum Continuous rating.

NORMAL RATED POWER

This rating is specified by Pratt & Whitney Aircraft and is the maximum recommended output for all normal operations such as routine climb and high speed level flight. A separate climb power rating is established for many engine models. Automatic rich mixture, or its equivalent, is required when using these ratings.

MAXIMUM CRUISING POWER

Maximum Cruising power is an arbitrarily established limit for use with automatic lean mixture, or its equivalent. Maximum Cruising limits which apply to all operators have been established for the Wasp Jr., Wasp, and Twin Wasp SIC3-G engines. In the case of the later models manufactured by Pratt & Whitney Aircraft, the Maximum Cruising power is determined individually for each operator so as to obtain the optimum balance between length of overhaul periods and the desired aircraft performance. This limit is established by consultation between the operator and Pratt & Whitney Aircraft after a review of all the factors affecting the conditions under which the engines operate. Individual limit increases may follow favorable experience, if desired.

For a considerable period, Normal Rated power has been regarded as 100% power and all other outputs have been measured by reference to this rating. For example, 50% power has meant 50% of Normal Rated power and 50% speed has meant 50% of Normal Rated speed. New aircraft performance requirements have brought about the revision of the system of ratings but a great many individuals base their concepts of power output in terms of percentage of Normal Rated power. A great portion of this book was written before this change and, as a result, power selection discussions are based on percentages of Normal Rated power.

The policy of establishing cruising ratings individually applies only to the Twin Wasp 'D' and later model engines. For previous models, manufactured by Pratt & Whitney Aircraft, the cruise ratings approximated the general limits of 0.30 bhp per cu. in. for the single row series and 0.375 bhp per cu. in. for the double row series. Ratings, based on these ratios proved to be a satisfactory limit for all normal, lean mixture cruising and have given an acceptable combination of durability and performance. In lieu of a positive definition of the Maximum Cruising rating, the use of limits based on the above ratios will insure that conservative powers are used pending receipt of more specific information. In all cases, operation within these limits will insure the use of powers that are in the range of economical fuel consumption.

When the Maximum Cruising rating is specifically defined, the maximum rpm for continuous cruise will also be indicated. It is not intended that this engine speed shall be used for all cruising powers and the most satisfactory results will be obtained by reducing the rpm as the output is lowered. Low engine speeds will give measurable returns in the form of fuel economy and increased durability, provided that a proper balance between power and rpm is maintained.

The low limit of rpm for any desired power is expressed in terms of bmep. While the ratings may not specifically mention a bmep limitation, experience has indicated the desirability of adhering to a definable relation between power and rpm. It is suggested that the operator base his power and rpm combination according to the method outlined in Part III, Pages 104-108.

RATINGS FOR TIME-LIMITED CONDITIONS

As with most mechanical devices, an aircraft engine is capable of sustaining an overload temporarily without impairing its reliability and without appreciably affecting its durability. Accordingly several ratings have been established setting up limits within which the engine may be safely operated for restricted periods of time at powers and speeds greater than those permitted for maximum continuous operation.

1. Take-Off. While take-off demands the greatest power output, it is a condition with

definite time limits. To obtain this output on the basis of a continuous rating would require a much heavier engine, and the aircraft's efficiency is accordingly increased by establishing a rating which permits the engine to meet take-off requirements, but limits this performance to a short period of time.

The specific time limitations are determined by the Military Procurement Agency or by the Civil Aeronautics Authority. As this period limitation is subject to change, the specific operating instructions must be consulted for information regarding a given engine model.

For engines with two-speed or two-stage superchargers the Take-off rating is available only in the lowest impeller ratio or stage of supercharging. Exceptions to this rule may be found with individual engine models. For information regarding any one model consult the applicable specific operating instructions.

2. Military Rating. Tactical and combat requirements necessarily dictate the amount of power that will be used in military operations. In meeting these demands military personnel are naturally less concerned with the life of the engine than with the offensive or defensive advantage of overload performance. The military rating establishes the maximum limited period performance for service aircraft, and is not available to other operators. In the lowest impeller ratio or stage of supercharging Military Power and rpm are usually the same as for take-off.

An aircraft engine can actually be run continuously under overload conditions of power and speed for much longer periods than those permitted by the ratings. However, the period of reliable operation is thereby reduced to an impractically short time. By imposing a time limit on Take-off and Military power ratings the cumulative effect of the overloads is distributed evenly over the period between overhauls, and the useful life of the engine accordingly lengthened.

3. Maximum Diving Speed. This rating establishes the maximum safe over-speed. It is dictated by the allowable reciprocating and centrifugal loads resulting from the high rpm which may be encountered during aircraft maneuvers. Maximum diving speed is usually limited to 30 seconds.

ADDITIONAL RATINGS

1. **Temperature and Pressure Ratings.** In addition to the power and rpm ratings which govern engine performance, limiting conditions of temperature and pressure are specified by the engine manufacturer, and the observance of these limits is mandatory. These ratings are:

- a. Cylinder Head Temperature—maximum
- b. Oil (Inlet) Temperature—maximum and minimum
- c. Oil Pressure—maximum and minimum
- d. Fuel Pressure—maximum and minimum

Each of these ratings is given for various operating conditions. The consequences of failure to observe these limits have already been discussed.

2. **Combat Ratings.** The conventional Normal Rated, Take-Off and Military power ratings are based on peacetime concepts of engine reliability and durability. In wartime these considerations are not necessarily the first importance, and tactical and combat demands warrant the use of powers in excess of those permitted under normal circumstances. The performance available on such occasions is entirely regulated by the military services, and the demonstration of the engine's suitability for this power output is not an obligation of the manufacturer. Operations of this type come under the category of combat ratings, and are not to be considered outside of the military services.

3. **Other Ratings** covering special applications may be supplied from time to time for individual engine models.

RELIABILITY STANDARDS

Standards of engine reliability are agreed upon by the engine manufacturer, on the one hand, and the procuring or regulating agency on the other. The accumulated experience of the past makes possible the establishment of testing standards that accurately demonstrate the ability of an engine to perform at given ratings at the standard of reliability specified or agreed upon. Competition gives every incentive to the manufacturer to offer the highest possible ratings. Over-conservatism in rating engine performance will result in long engine life—but often on the manufacturer's shelves, since oper-

ators will naturally select powerplants that are permitted to deliver a high percentage of their maximum potential output. On the other hand, over-enthusiasm regarding ratings is held in check by the consideration that the engine must pass a rigid proof test, and the manufacturer's reputation will suffer if the reliability of his product fails to measure up to the claim made for it. The performance offered is thus the manufacturer's best judgment of the output an engine can deliver, within the accepted standard of reliability and as demonstrated by the type test.

ENGINE DURABILITY

Durability is the measure of engine life obtained while maintaining the desired reliability. The fact that an engine model has successfully completed its type or proof test is an indication that it can be operated in a normal manner over a long period before requiring overhaul. However, no definite time interval between overhauls is specified or implied in the rating.

The durability realized is determined largely by the type and condition of operation. The period between overhauls may be represented roughly by Fig. 26.

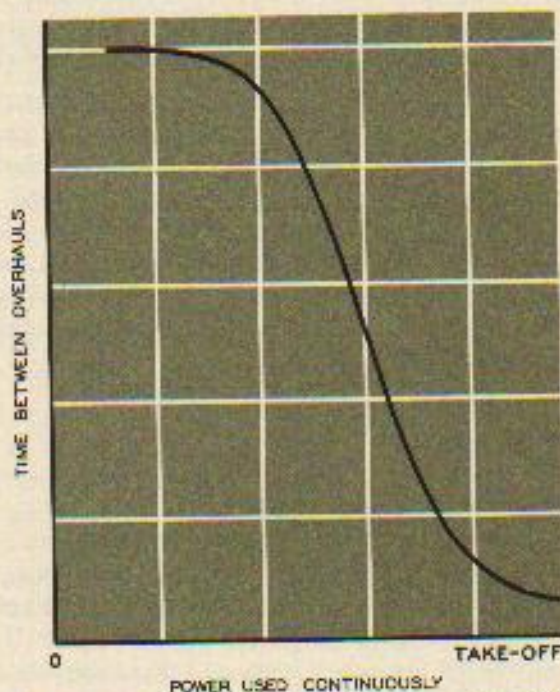

Fig. 26 — Effect of Continuous Power on Durability

The values shown in Fig. 26 are only approximate and vary even at the same percentage of power output because of such other factors as

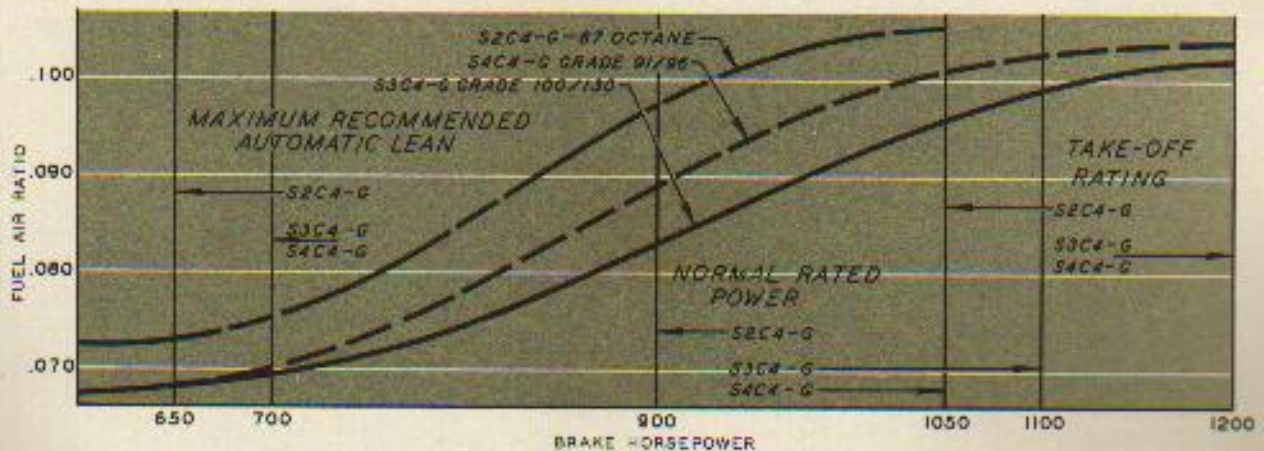

Fig. 25 — Twin Wasp Ratings

temperature and type of installation. The point to be understood is that the period of reliable engine operation (or durability) is largely determined by the continuous output used.

GRADE OF FUEL

The same basic model of engine may be offered with different ratings available depending on the grade of fuel to be used. The only difference between these otherwise identical engines are the variations in the carburetor settings required to furnish a flow of fuel sufficient to suppress detonation. For example: the Twin Wasp S3C4-G has a carburetor setting which permits the engine to develop its ratings with grade 100/130^{*} fuel only. The Twin Wasp S4C4-G has identical ratings, but it is provided with a carburetor set sufficiently richer to permit these ratings to be developed with grade 91/96

^{*}The reader may not be familiar with the system of grading fuels represented by the designation "100/130." Heretofore all fuel has been described by one octane number such as "87 octane" or "100 octane." However, it has been found that the single number does not adequately describe the anti-knock characteristics of a fuel throughout the usable range of mixture strength. A gasoline meeting 100 octane requirements at rich mixture may be capable of an anti-knock rating of only 87 octane if the mixture is lean. Accordingly, it has become prevalent to identify the fuel grade by two numbers: the first signifies the lean mixture anti-knock rating, the second number signifies the rich mixture anti-knock rating. A fuel like that described above would be designated as 87/100; 87 being its lean rating and 100 being its rich rating. The following are the grades of fuel in current use:

73 octane	No rich mixture rating
87 octane	
grade 91/96	
grade 100/130	
grade 115/145	

fuel. The Twin Wasp S2C4-G has a third carburetor setting, which permits the use of 87 octane fuel with lower ratings. The only differences in the bills of materials of these three engines are the carburetor parts which give the required variations in fuel flow.

In the case of engines provided with carburetor settings which permit the use of lower grade fuel, higher grade fuel may be used without change in operating procedure. For example: the Twin Wasp S2C4-G may be used with either 91/96 or 100/130 fuel. It would be permissible to use the ratings available with the higher grade fuel, but operation would be unsatisfactory because of excessive enrichment.

It is not permissible to use fuels of lower grade than that specified for the carburetor setting of the engine. This practice was resorted to during the war in order to conserve combat quality gasoline for the fighting theaters. However, this was distinctly an emergency procedure and, in spite of the fact that engines were operated at considerably reduced powers, the results were unsatisfactory. By way of illustration: if the Twin Wasp S3C4-G engine were to be operated on grade 91/96 (instead of 100/130), with the take-off rating reduced to 1100 horsepower, the mixture strength provided by the carburetor at that power output would be insufficient to prevent detonation.

The above engine models are no longer manufactured or certified for operation. Their use in the above example is for illustrative purposes only.

Pages 62 through 64
have been omitted by the revision

GROUND OPERATION

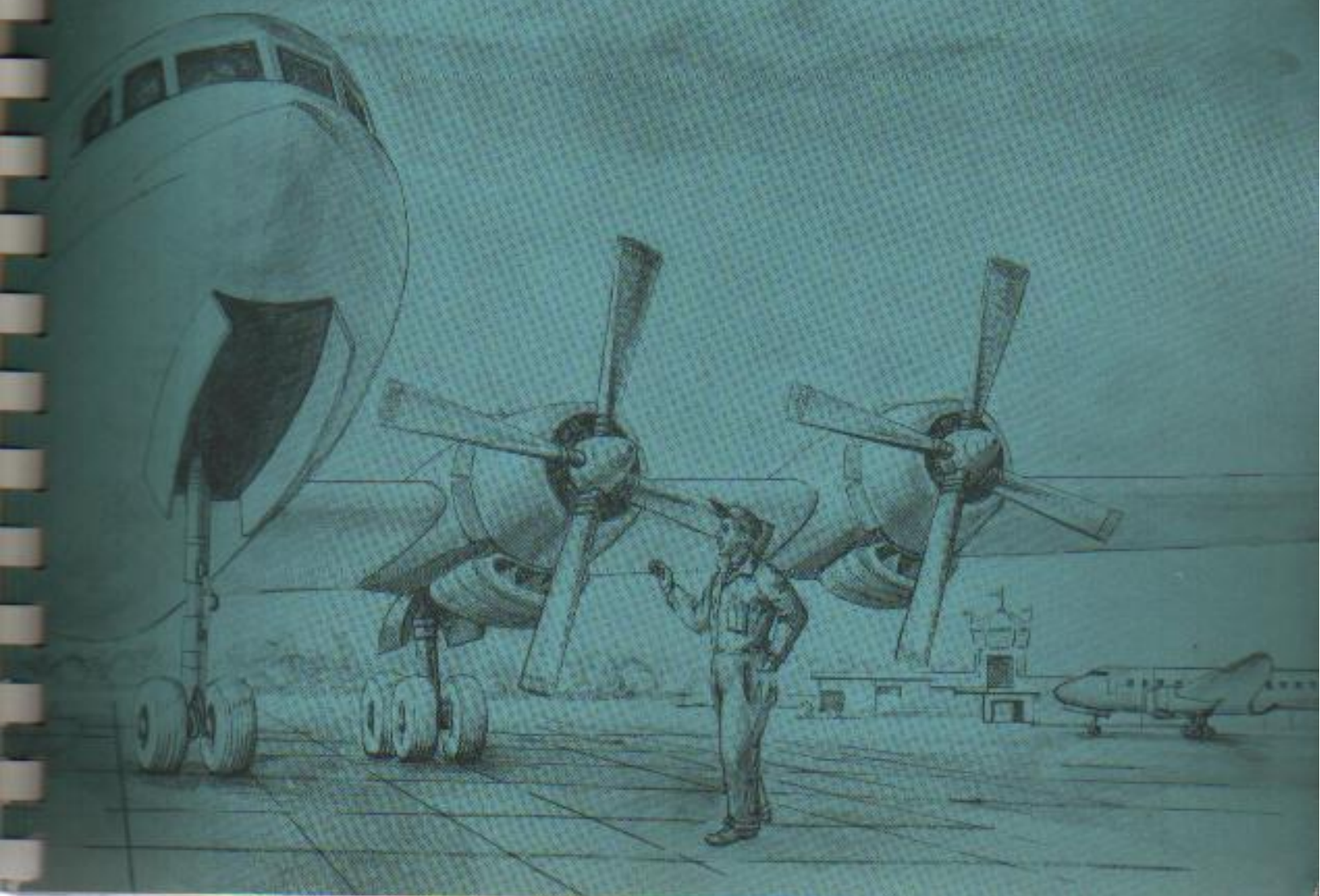

PART III
GENERAL OPERATING INSTRUCTIONS
STARTING

**GENERAL**

There are a number of methods for obtaining consistent starts with any engine model. Most of these methods are equally good even though they may vary considerably in detail. Some will give sure results for one individual but fail to give satisfaction for others; while some methods can be used safely only by the most experienced personnel.

The methods outlined in this section have proved effective if followed exactly and without individual changes. They are based on the experience of Pratt & Whitney Aircraft, and are recommended as it is known they can give the desired results with the greatest protection to the engine. It is not expected that consistent results will always be immediately obtained by individuals new to this equipment. These procedures require practice and familiarity with

the installation so that the various control manipulations will be accomplished effectively and without hesitation or lost motion.

On engines using the pressure injection carburetor, Pratt & Whitney Aircraft recommends that the start be accomplished without introducing fuel into the supercharger before starting by use of the mixture control, a practice commonly known as "wetting the blower." The use of the mixture control to dump liquid fuel into the induction passages may cause the engine to "hydraulic" (see page 73), and the record of engines damaged by the misuse of the mixture control testifies to the soundness of this recommendation. It is recommended that the mixture control remain in idle cut-off at all times that the engine is not firing except in the instances that are specifically mentioned in the instructions that follow.

In general, three different starting procedures will cover all Pratt & Whitney Aircraft engines; one for engines using float type carburetors and the other two for engines using pressure injection carburetors. These latter two procedures vary basically because of differences in priming systems. The specific procedures for each of these starting procedures follow; the various steps are discussed in detail on Pages 70-82.

For any particular engine, consult the applicable Specific Operating Instructions.

STARTING PROCEDURE: A — Engines with Float Carburetors:

Control Position Check

a. Ignition	— Off
b. Mixture	— Pull lean or idle cut-off
c. Propeller	— Hamilton Standard counterweight type (not Hydromatic) at low rpm (high pitch); others at high rpm (low pitch)
d. Carburetor air heat	— Cold
e. Carburetor air filter	— Unfiltered (or off)
f. Cowl flaps	— Pull open
g. Oil cooler shutters	— Closed
h. Fuel supply	— Off
i. Throttle	— $\frac{1}{2}$ open with electric direct cranking, inertia or combination inertia-direct cranking starters; $\frac{1}{4}$ open with cartridge starters

Starting Procedure

- If inertia or cartridge starter is used, pull propeller through in the direction of normal rotation for at least five revolutions of the crankshaft. If direct cranking starter is used turn engine over for eight crankshaft revolutions.
- Turn on fuel supply from suitable tank.
- Move mixture control to full rich.
- Operate wobble pump slowly, or turn on electric auxiliary fuel pump momentarily, until fuel pressure registers 3 psi.
- If inertia type starter is used, begin energizing starter while priming.
- Prime:
 - If carburetor has integral primer:
 - Move mixture control to full lean.
 - Pump throttle through complete travel for number of strokes necessary to give required prime.
 - Return mixture control to full rich.
 - Operate wobble pump slowly or turn on electric auxiliary fuel pump momentarily until fuel pressure registers 3 psi.
- If separate primer pump is used:
 - Keep mixture control in full rich.
 - Prime as required.
- If inertia or cartridge starter is used, turn ignition to "Both On."
- Maintain 3 psi fuel pressure with wobble pump or turn on the electric auxiliary fuel pump.
- Engage starter (and ignition booster, if separately controlled).
- If direct cranking starter is used, wait for engine to turn two revolutions. Watch for indications of "hydraulicking." If none, turn ignition to "Both On."
- After engine fires adjust throttle to hold engine speed at 600 rpm.

Note: Watch oil pressure gage. If oil pressure does not register within 10 seconds, STOP engine and investigate.
- If equipped with Hamilton Standard counterweight type (not Hydromatic) propeller, move control to high rpm (low pitch).
- When oil pressure shows, advance throttle to obtain 1000 rpm.

If a start is not made in a reasonable time, it is possible that:

 - Engine is overloaded (over primed) as indicated by discharge of fuel from carburetor drain, or, in the case of a cold engine, by the presence of liquid fuel in the exhaust outlets of the primed cylinders. In this case:
 - With direct cranking starter:
 - Continue cranking.
 - Place mixture in full lean.
 - Discontinue operating wobble pump or turn off the electric auxiliary fuel pump.
 - Fully open throttle.
 - After eight revolutions retard throttle, place mixture control in full rich and repeat starting procedure.

Note: It is frequently possible to effect a start while clearing out the engine, in which case the operator must be ready to retard the throttle immediately and move the mixture control to full rich.

b. With inertia or cartridge starter:

- (1) Turn off the ignition.
- (2) Fully open throttle.
- (3) Pull propeller through about 5 revolutions in direction of normal rotation to clear engine.
- (4) Retard throttle and repeat starting procedure.

2. Engine is under-primed.

In this case:

- a. Repeat priming procedure to give engine additional prime.
- b. Repeat starting procedure.

If it is still not possible to start the engine, check ignition or carburetor for malfunctioning.

STARTING PROCEDURE: B.—Engines with Pressure Injection Carburetors and Using Cylinder Intake Port Priming.

Control Position Check

Ignition	— Off
Mixture	— Idle cut-off
Propeller	— Hamilton Standard counterweight type (not Hydromatic) at low rpm (high pitch); Others at high rpm (low pitch)
Supercharger (when applicable)	— Single-Stage—low; Two-Stage—main or neutral Turbo—off
Carburetor heat	— Cold
Carburetor air filter	— Unfiltered (or off)
Cowl flaps	— Full open
Oil cooler shutters	— Closed

Starting Procedure

1. If inertia or cartridge starter is used, pull propeller through in the direction of normal rotation for at least five revolutions of the crankshaft. If direct cranking starter is used turn engine over for eight crankshaft revolutions.
2. Turn on fuel supply from suitable tank.
Note: Keep MIXTURE CONTROL IN IDLE CUT-OFF at all times when engine is not turning over.
3. If inertia starter is used, start energizing starter while priming.
4. Prime:
 - a. If hand priming pump is used:

- (1) Operate wobble pump to maintain 3 psi fuel pressure or turn on electric auxiliary fuel pump.
- (2) Prime as required.

b. If electrically operated priming valve is used.

- (1) Operate wobble pump to maintain required fuel pressure or turn on electric auxiliary fuel pump.
- (2) Prime as required.

5. If inertia or cartridge starter is used, turn ignition to "Both On."
6. Operate wobble pump to maintain required fuel pressure or turn on electric auxiliary fuel pump.
7. Engage starter or fire cartridge.
8. If direct cranking starter is used, wait for engine to turn two revolutions. Watch for indications of "hydraulicking." If none, turn ignition to "Both On."
9. When engine fires, move mixture control immediately to automatic rich position.
10. Maintain fuel pressure with wobble pump or electric auxiliary fuel pump until engine pump builds up specified fuel pressure.
11. Adjust throttle to maintain about 600 rpm until oil pressure shows.

Note: Watch oil pressure gage. If oil pressure does not register within 10 seconds, STOP engine and investigate.

12. If equipped with Hamilton Standard counterweight type (not Hydromatic) propeller, move control to high rpm (low pitch).
13. When oil pressure shows, adjust throttle to 1000 rpm.

If engine does not fire almost immediately:

1. With direct cranking starter (except models using updraft carburetors)
 - a. If engine is under-primed:
 - (1) Continue cranking.
 - (2) Maintain fuel pressure.
 - (3) Move mixture control to automatic rich for not more than 3 seconds.
 - (4) Return mixture control to idle cut-off for 5 seconds (unless engine fires meanwhile).
 - (5) If necessary repeat steps (3) and (4) one to three times.

b. If engine is overloaded:

- (1) Continue cranking.
- (2) Place mixture control in idle cut-off.
- (3) Open throttle wide.
- (4) After about 8 revolutions of the engine retard throttle and repeat starting procedure, if engine has not started during this clearing-out procedure.

2. With inertia or cartridge starter:

a. If engine is overloaded:

- (1) Keep mixture control in idle cut-off.
- (2) Discontinue operation of wobble pump or turn off electric auxiliary fuel pump.
- (3) Turn off ignition.
- (4) Open throttle wide.
- (5) Clear engine by pulling propeller through 8 revolutions.
- (6) Retard throttle and repeat starting procedure.

b. If engine is under-primed:

- (1) Turn propeller forward $\frac{1}{2}$ revolution to disengage starter jaw.
- (2) Re-prime.
- (3) Repeat starting procedure.

If start is not obtained after a reasonable number of attempts, an investigation should be made to determine the cause.

Except in the coldest weather the starting procedure "C" following is recommended as being preferable for engines having electric priming valves and equipped with direct cranking or combination inertia — direct cranking starters.

STARTING PROCEDURE: C. — Engines with Pressure Injection Carburetors and with Blower Rim, Blower Throat or Carburetor Priming.

Many of the later engines are provided with blower rim, blower throat or carburetor priming systems. These priming systems introduce the priming fuel into the blower rim or the blower throat instead of the cylinder intake port. The priming flow is generally much greater than with cylinder intake port prim-

ing, and all the cylinders receive a combustible fuel/air mixture rather than just a limited number of primed cylinders. Consequently, the undesirable practice of resorting to the use of the mixture control to supplement the priming fuel flow is eliminated.

Instead of priming before engaging the starter, the priming switch is closed simultaneously with the starter engaging switch. As a combustible fuel/air mixture range is reached the engine will fire, and should be accelerated with the primer, after which the mixture control is slowly moved out of the idle cut-off position to automatic rich, using prime as required until the start is secure. To avoid overloading a warm engine, flicking the primer switch is advisable. A colder engine will require constant priming until it fires.

The elimination of priming before cranking and the use of the mixture control to supplement the prime has eliminated or reduced the occurrence of "hydraulic" and other hazards associated with over-priming.

A typical starting procedure follows:

Control Position Check

Ignition	— Off
Mixture	— Idle cut-off
Propeller	— Hamilton Standard counter-weight type (not Hydro-matic) at low rpm (high pitch); others at high rpm (low pitch).
Supercharger (when applicable)	— Single stage — low Two stage — main, or neutral Turbo—off.
Carburetor air heat	— Cold
Carburetor air filter	— Off (unfiltered)
Cowl flaps	— Full open
Oil cooler shutters	— Closed

Starting Procedure

1. Fuel supply "On".

Note: Keep mixture control in Idle-Cut-Off at all times when engine is not firing.

2. Auxiliary pump "On".

3. Turn engine over with starter for eight crankshaft revolutions.

4. Turn Ignition "On".
5. Simultaneously close primer switch.
6. After engine fires, slowly ease mixture control out of Idle Cut-Off to Automatic Rich using prime as required until engine is securely started.
7. Maintain fuel pressure with auxiliary fuel pump until engine pump builds up specified fuel pressure.
8. Adjust throttle to maintain about 600 rpm until oil pressure shows.

Note: Watch oil pressure gage. If oil pressure does not register within 10 seconds, STOP engine and investigate.

9. If equipped with Hamilton Standard counterweight type (not Hydromatic) propeller, move control to high rpm (low pitch).
10. When oil pressure shows, adjust throttle to 1000 rpm.

If engine fires but does not continue to run:

1. Move mixture control back to idle cut-off immediately.
2. Continue cranking and priming.

If a start is not obtained within a reasonable time, an investigation should be made to determine the cause.

NOTE ON STARTERS

Starters are commonly of one of four types: inertia, direct cranking, combination inertia-direct cranking, and cartridge. The operator should in all cases consult the applicable instructions of the manufacturer to ascertain the time limits governing operation and cooling for the particular starter being used. The following is simply a general description of the several types.

1. **The Inertia Starter** consists of a small, heavy flywheel which can be made to turn at high

speed (15,000 to over 20,000 rpm) by means of a hand crank or an electric motor, thus storing a considerable amount of energy in the flywheel. The starter is energized by hand, or by means of a toggle switch, after which it is engaged by a lever-operated clutch, or a starter switch, and the momentum of the flywheel turns the engine over a few revolutions. Power is supplied by hand, from the aircraft's batteries, or from an independent source of current.

2. **The Direct Cranking Starter** is comparable to the conventional automobile starter. It is engaged by a starter switch and turns the engine continuously. Power is supplied for the electric starter motor from the aircraft's batteries or an independent source of current. To avoid overheating, the starter should not be operated continuously for more than one minute, and should be allowed to cool before attempting a second start.

3. **The Combination Inertia-Direct Cranking Starter**, as the name implies, incorporates an electrically energized (accelerated) flywheel and a direct cranking electric motor—the former to overcome the initial stiffness of the engine, the latter to turn it continuously. The starter is normally first energized (accelerated) by means of a switch, after which it is engaged to the engine by means of a second switch. (A double throw switch may be made to serve both purposes.) As the energy of the flywheel is dissipated, the starter motor continues to turn the engine. In the case of a warm engine, it is often unnecessary to energize the starter beforehand, and it may be used as a direct cranking starter. Continued operation of more than one minute should be avoided to prevent overheating, and sufficient time must elapse between attempted starts to allow the electric motor to cool. Power is supplied in the same manner as for the direct cranking starter.

4. **The Cartridge Starter** develops its power by the combustion of a slow-burning powder contained in a cartridge which is inserted in the starter cylinder by means of a breech loading mechanism. The piston of the starter cylinder drives a helical spline which in turn motors the engine over. The crankshaft is turned very rapidly for a little less than one revolution, after which the momentum of the engine's parts will cause it to turn once or twice more.

DISCUSSION

1. Control Position Check

By checking off the position of each engine and accessory control the operator makes certain that all powerplant units are in readiness for operation, and satisfies himself that no item is in a position to cause damage.

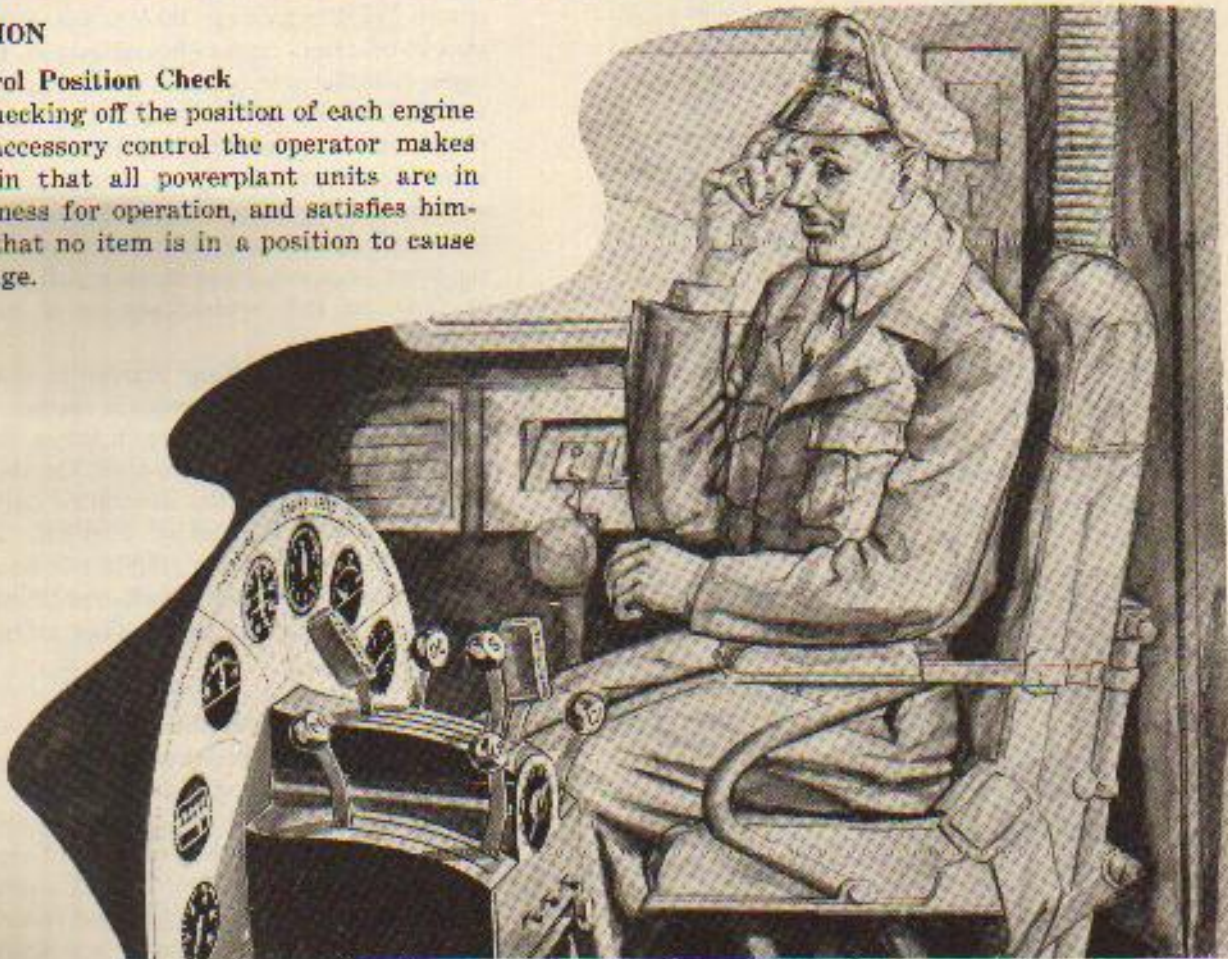

a. Ignition

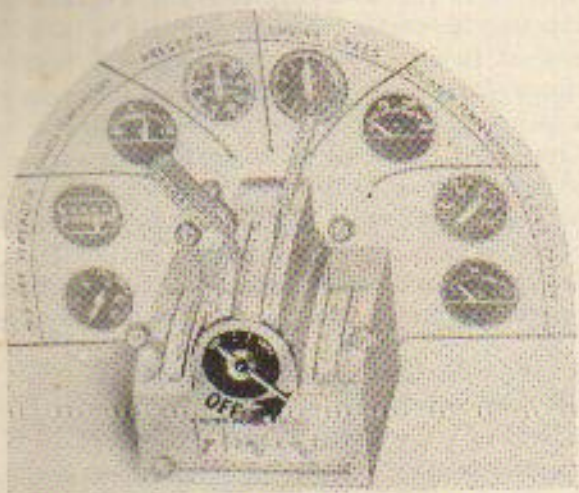

The ignition switch should be in the "Off" position at all times when the engine is not running, except as the starting procedure may require. This is essential for the protection of personnel who may be servicing the aircraft.

During the starting procedure ascertain that all is clear of the propeller before turning on the ignition switch.

b. Mixture

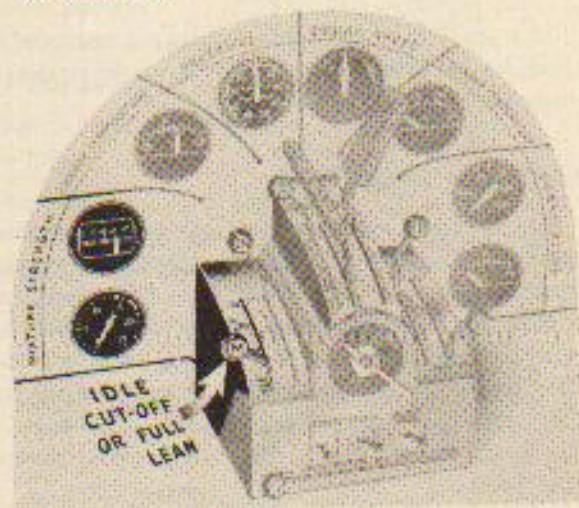

In the case of pressure injection carburetors it is essential that the mixture control remain in idle cut-off at all

times when the engine is not firing, except in the instances specifically mentioned (see page 67). If the fuel is under pressure, it is discharged into the induction system from the carburetor when the mixture control is out of the idle cut-off position. Some of the discharged fuel may collect in the lower intake pipes and cause the engine to "hydraulic" when starting is attempted. Fuel discharged through the fuel drain is a potential fire hazard.

c. Propeller Control



With controllable (variable) pitch propellers, the rpm control will have been placed in the high rpm position at the time of the previous shut-down. The control should be left in this position in order to reduce the load on the engine during the starting and warm-up period. The exceptions to this rule are the Hamilton Standard counterweight propellers (two-position or variable pitch—but not the Hydromatic). With these propellers the engine should be shut down with the propeller rpm control in low rpm (high pitch) position. This is to retract the propeller-operating cylinder to protect it from dust, and to empty the oil from the cylinder that otherwise might congeal in cold weather. The propeller control should not be shifted to high rpm until after starting the engines and obtaining oil pressure.

d. Supercharger Control (where applicable)

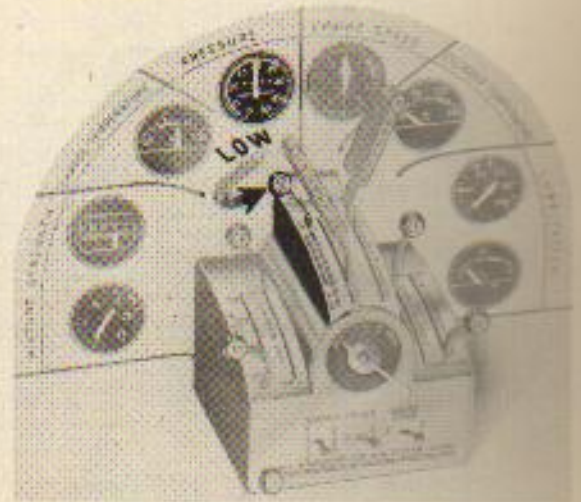

The supercharger control lever for single-stage, two-speed engines should be placed in the low position; and for two-stage engines in the main stage (neutral) position. This causes the minimum load to be imposed on the impeller drive during starting.

Engines with turbosuperchargers should have the turbosupercharger control in the "Off" position.

e. Carburetor Heat and Carburetor Air Filter



Carburetor air heat must be in the cold position (Off), and carburetor air filter (where applicable) must be in the unfiltered position (Off) in order to prevent damage to these installations in case of backfires.

f. Cowl Flaps

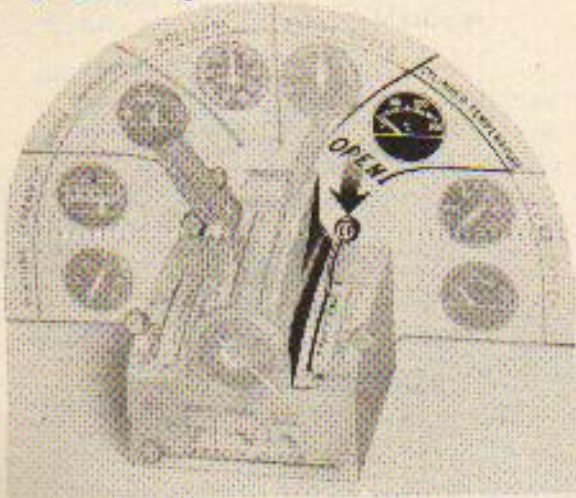

During all ground operation of the engine it is essential that the cowl flaps (where applicable) be fully open regardless of outside air temperature or the temperature of the cylinder heads. The ignition harness, as well as other powerplant items, require all possible circulation of air to prevent serious damage. Closing of the cowl flaps to accelerate the warm-up will lead to burning of the insulation on the ignition leads.

g. Oil Cooler Shutters

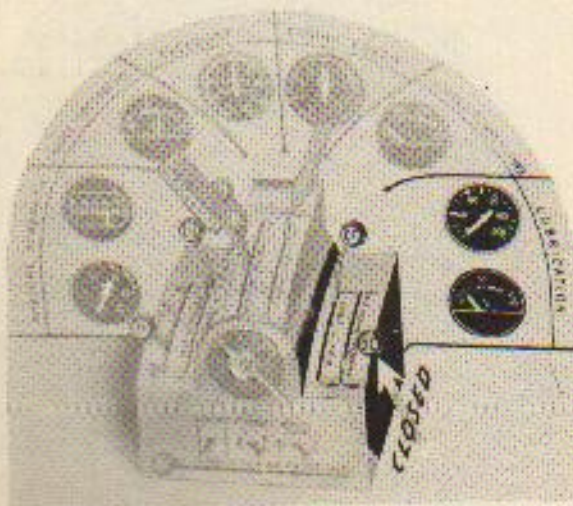

Oil cooler shutters (where applicable) are closed to assist in heating the oil during the warm-up period after starting.

h. Fuel Supply



As a safety factor the fuel supply should be turned off when the engine is shut down, and not turned on until preparation for starting is made.

i. Throttle

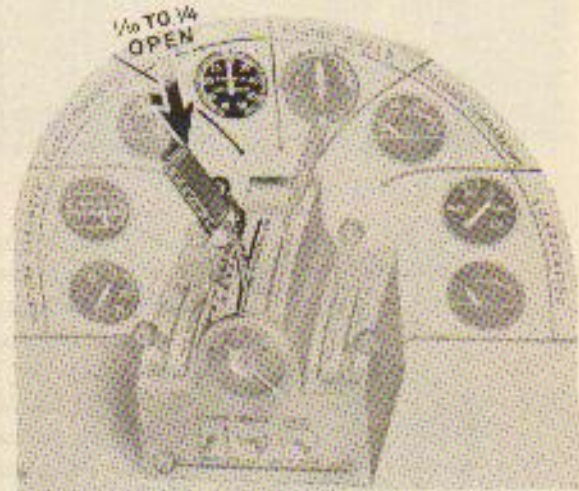

The position of the throttle at the instant the engine first fires is an important factor in consistent starting. It is important to understand that during the period of cranking and until the engine accelerates, normal idling speed airflow is little, if any, affected by the throttle position, as little obstruction is offered to the slow velocity through the carburetor at this time. Airflow is then mainly affected by the rpm of the engine as each cylinder will draw in so

many cubic inches of air at atmospheric pressure regardless of the throttle position. However, fuel-flow is closely related to the position of the throttle, but in a manner which differs between the two basic types of carburetors.

(1) **Float Carburetors**

In the idling range of operation this type of carburetor furnishes fuel only when a definite pressure differential exists between the idle discharge and the fuel in the bowl. If the throttle is too far advanced, this differential becomes insufficient to produce the required flow with the results that the engine cannot properly fire and, in all probability, back-firing will occur.

(2) **Pressure Carburetors**

During the starting and idling period the pressure carburetor furnishes fuel entirely as the result of the position of the idle valve, which is directly linked to the throttle. Airflow has no effect upon the quantity of fuel discharged. If the throttle is too far advanced, the fuel discharge will be too great for the amount of airflow that is being drawn into the cylinders with the result that the engine will be overloaded.

In setting the throttle opening before starting, the purpose is to secure the proper fuel-air ratio for combustion and the throttle opening is affected by the type of carburetor and starter employed. For example, cartridge starters, which turn the engine over at a higher rpm than other types and consequently produce more airflow through the carburetor require a slightly wider throttle opening.

2. **Clearing the Engine**

After the previous shutdown, the warm residual oil clinging to the power section surfaces flows downward toward the lower cylinders. Some of this oil seeps past the piston and piston rings, accumulating in the combustion chamber. If sufficient liquid is present, the true compression ratio will

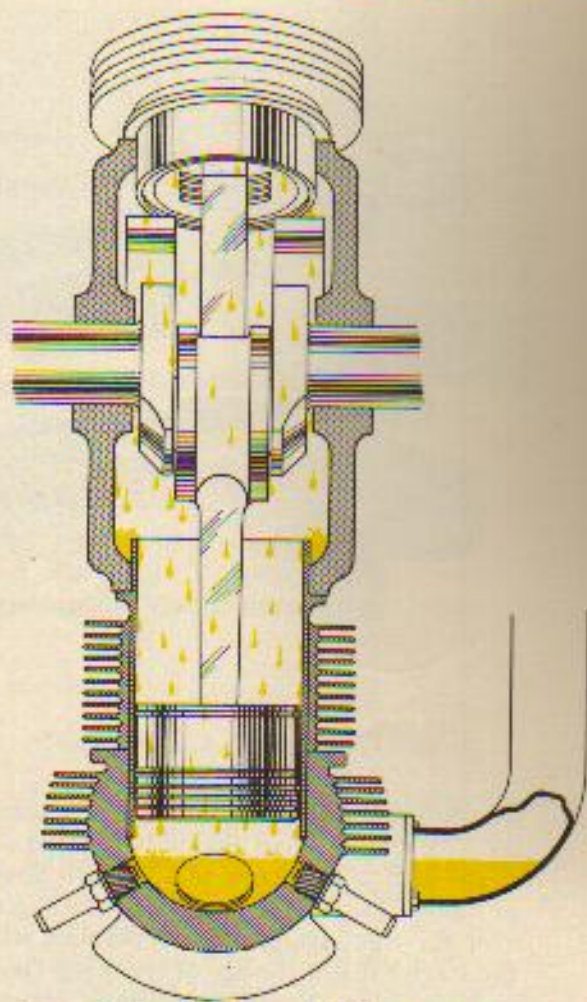

be raised and extremely high pressures will be produced when the piston of the cylinder is moved downward on the compression stroke. These pressures can be raised to such an extent that damage to the cylinder, piston, or link rod will result. In ex-

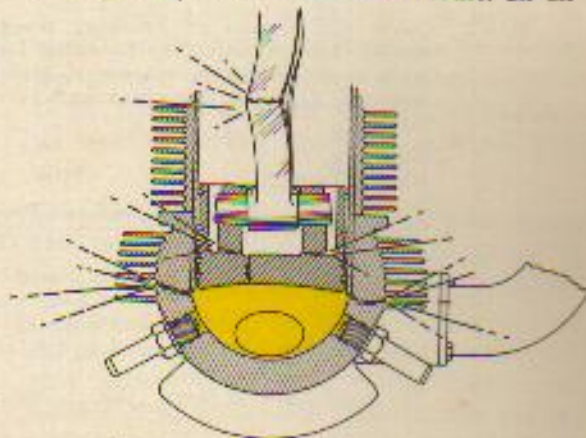

treme instances the piston may actually "bottom" against the liquid. This is known as "hydraulic locking" the engine.

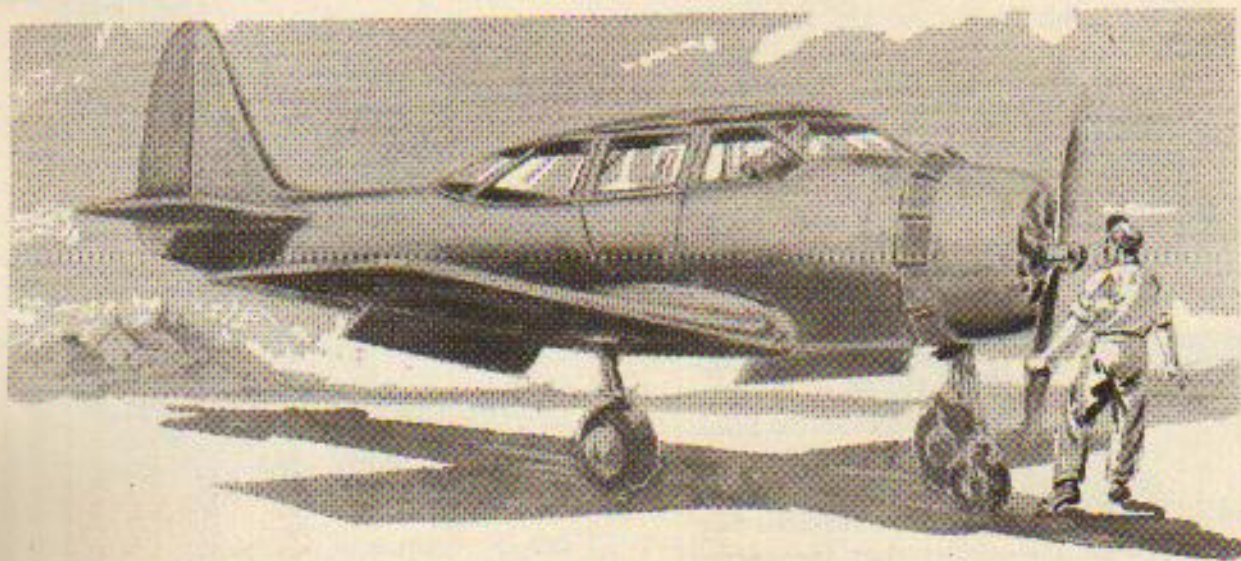

To protect the engine against this possibility, any excess liquid should be cleared out if the engine has stood idle for two hours or more. This is done by turning the engine over for eight crankshaft revolutions with the starter if it is the direct cranking (non-inertia) type. Eight revolutions insures that any liquid fuel in the intake pipes will be evaporated by the passage of air. If other than direct cranking starter is used the propeller must be pulled through by hand.

HINT: Count the number of propeller blades turned through, using the following formula to determine the number of blades required. To obtain five crankshaft revolutions:

$$\begin{array}{l} \text{No. Prop.} \\ \text{Blades Turned} \\ \text{to obtain 5} \\ \text{Crankshaft Revs.} = \frac{5 \times \text{No. Blades on Prop.}}{\text{Reduc. Gear Ratio (1)}} \end{array}$$

$$\text{or} = \frac{5 \times \text{No. Blades on Prop.} \times \text{Reduction Gear Ratio (2)}}{\text{Reduc. Gear Ratio (1)}}$$

(1) Gear Ratio in form: 2:1, 3:2, etc. (i.e., 2/1, 3/2, etc.)

(2) Gear Ratio in form: .500:1, .667:1, etc.

Thus: In the case of a three-bladed propeller and a 16:9 (or .5625:1) propeller reduction gear, 9 blades should be turned through to obtain 5 revolutions of the crankshaft.

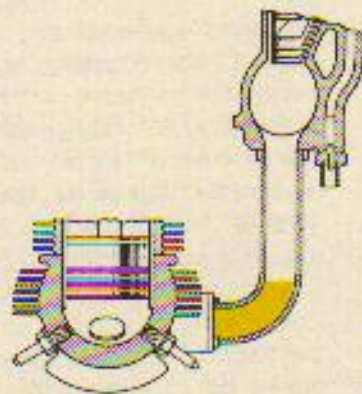

Do not pull through in the reverse direction of normal engine rotation. "Backing up" the engine will result in pushing the liquid into the intake pipes, where it will be ready to return to the cylinders on the next intake stroke.

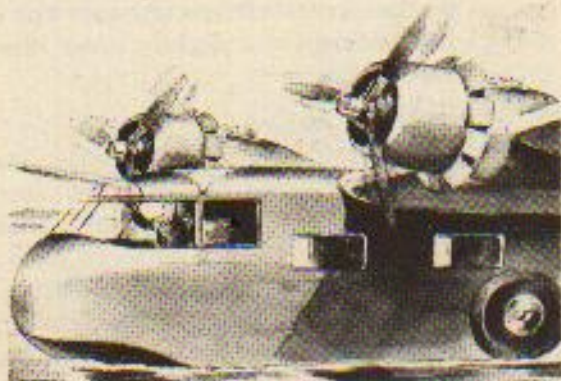

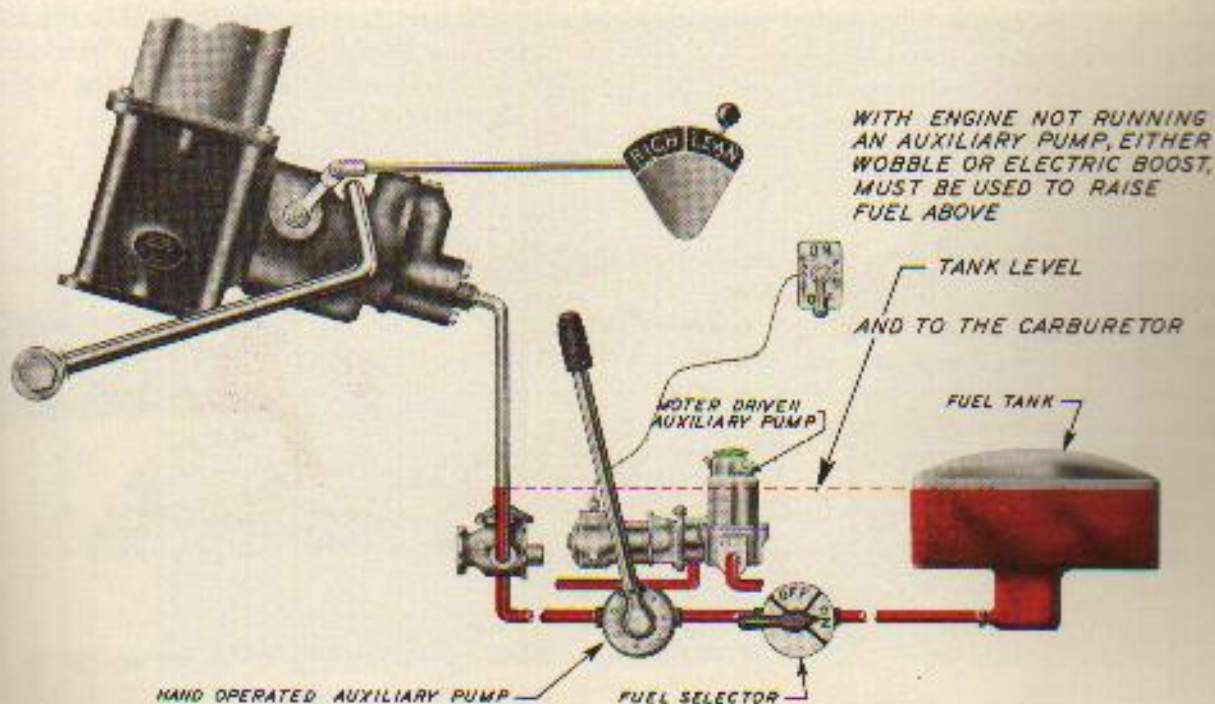

While pulling the propeller through by hand or with the starter, the operator must be alert for any sign of the piston being forced against unusually high compression. This will be evidenced by a sudden resistance, a sudden slowing down or complete stoppage. This is sufficient indication that an excess quantity of liquid is present in the lower cylinders, and any further attempt to turn the engine over will result in damage.

If the presence of liquid is suspected, remove a spark plug from each of the bottom cylinders before turning the engine over. This is especially important when the engine is provided with high exhaust tailpipes which do not allow drainage from the lower cylinders.

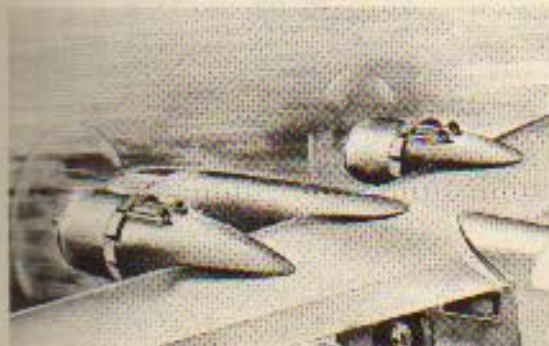

3. Getting Fuel to the Carburetor

Turning on the fuel selector valve opens a path for the fuel from the tank to the carburetor, but unless the tank is located above the carburetor the fuel cannot reach the carburetor. Therefore, it is necessary to apply pressure to fill the lines to the carburetor, and further, in the case of pressure injection carburetors, to apply sufficient additional pressure to discharge fuel from the carburetor into the engine induction passages when the mixture control is moved out of idle cut-off. Inasmuch as the engine fuel pump is not operating, an auxiliary fuel pump is necessarily used. On many installations this is a hand pump, commonly known as a wobble pump. On other installations, particularly for the larger engines, an electric driven auxiliary fuel pump is used.

With float carburetors, the wobble pump should be operated slowly until 3 psi is indicated on the fuel pressure gage, or the electric auxiliary pump should be turned on momentarily to obtain this pressure. By this means the lines and the carburetor bowl will be filled with fuel and the air expelled. Continued pumping or greater pressure may result in fuel overflowing the carburetor bowl and creating a fire hazard.

In the case of pressure injection carburetors, the minimum pressure required will vary with the particular engine model, and the pressure can be applied and maintained without danger, provided the mixture control is kept in idle cut-off until the engine fires.

If the mixture control is moved out of idle cut-off, fuel will be discharged into the induction system. As the engine is not turning over, only the air contained in the supercharger will absorb vaporized fuel. The drain valve will carry away only a portion of the liquid that the carburetor discharges. The balance of the liquid fuel pours into

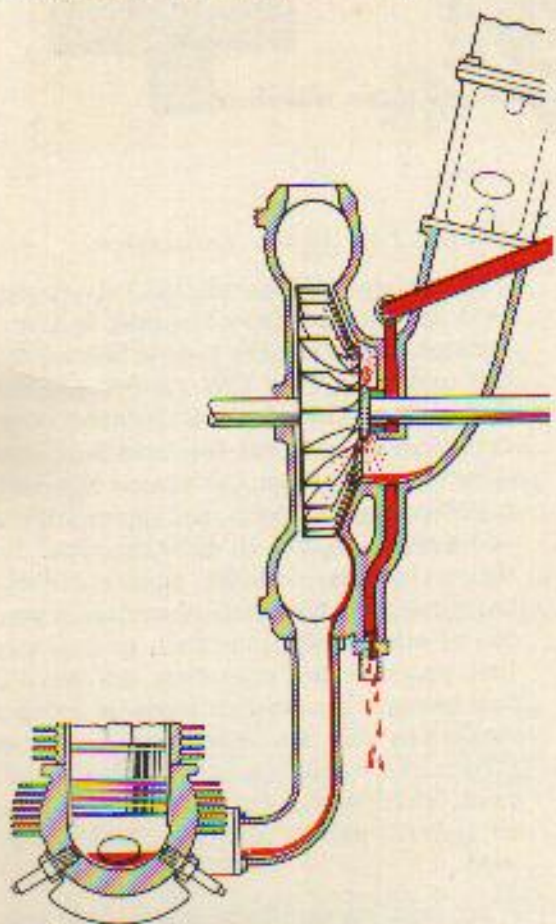

the lower intake pipes, paving the way for "hydraulicking."

4. Energizing Inertia Starter

Energizing the inertia starter (where used in conjunction with cylinder intake port priming) while priming the engine results in the least time delay between the comple-

tion of the prime and engaging the starter. This is desirable in order to minimize the possible effect of raw fuel lying inside the engine.

5. Priming

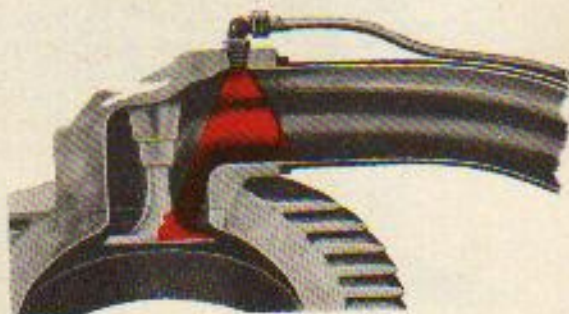

As the carburetor cannot supply the cylinders with a combustible mixture of air and fuel without sufficient airflow, the initial firing charge must be prepared by other means. The air contained in the cylinders and induction passages and that introduced during cranking must be used in providing the initial firing charge. By spraying fuel into this air, a fuel-air mixture that is within the combustible range is prepared to give the initial firing impulses which turn the engine over at a speed that will bring airflow and normal carburetion. The fuel is furnished through the priming

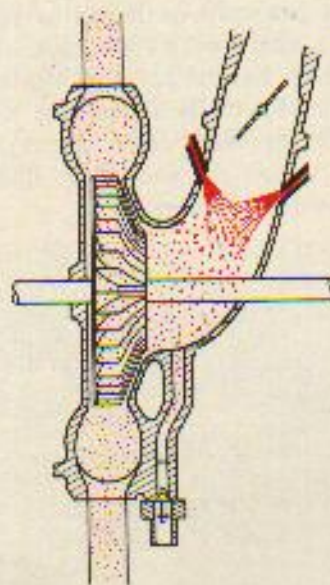

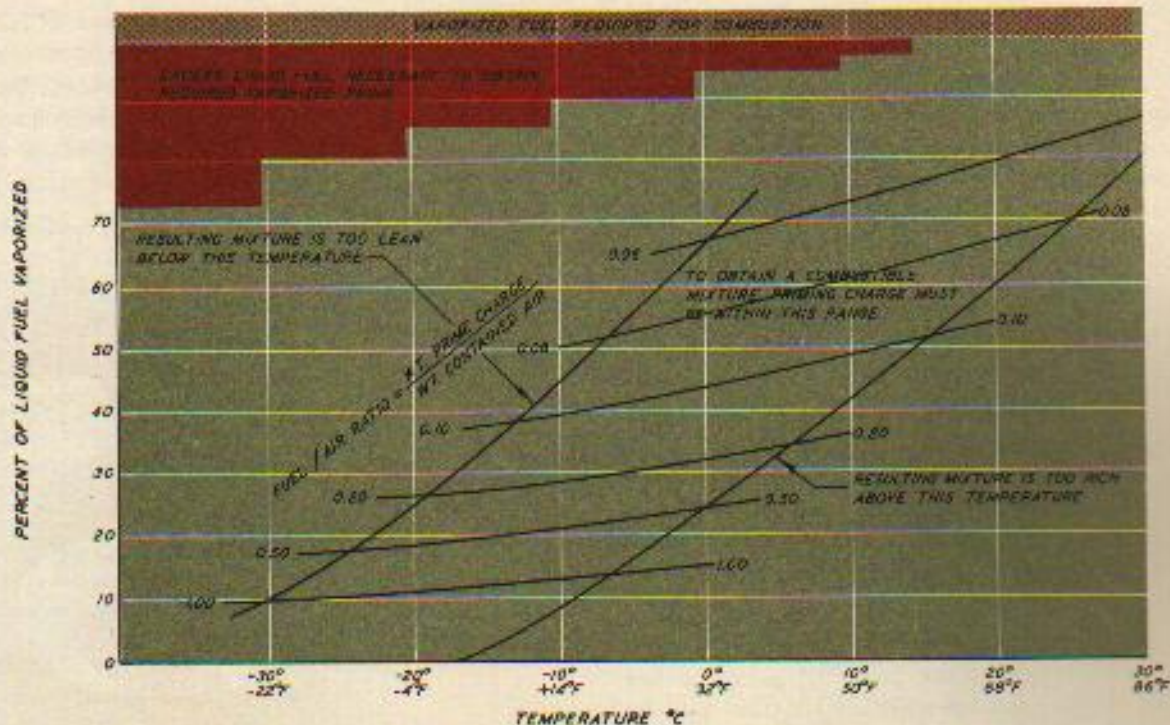
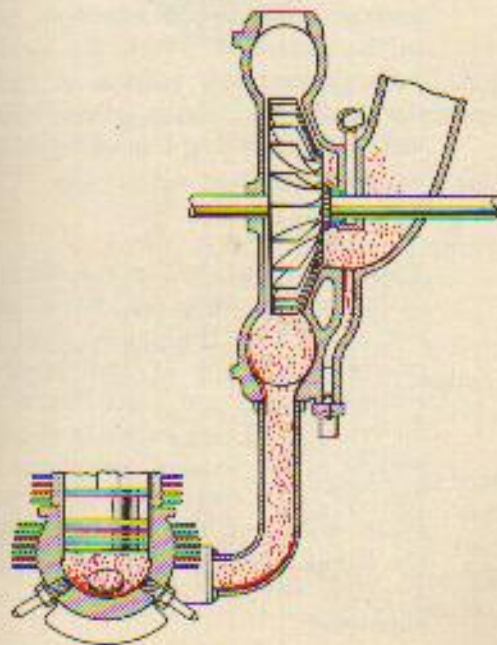

Fig. 27 — Effect of Temperature on Required Prime

system. It is atomized by nozzles to assist the vaporization of the fuel and is discharged into the induction system or the intake ports of the top cylinders of the engine depending on the type of priming system on the engine.

The ideal prime should contain enough completely vaporized fuel to fill the induc-



tion passages with a combustible fuel-air mixture. As more air is introduced by turning the engine the fuel-air mixture will be maintained by the priming fuel flow until a spark ignites it and a start is accomplished.

If the outside air temperature is above 75 F (25 C) or if the engine is warm from previous operation, it is possible that sufficient fuel-charged air remains in the induction system as a result of residual fuel to obtain a start. Under these circumstances no prime is required. Under all other conditions it is necessary to prime.

The amount of prime required varies with the temperature of the air and of the engine. The quantity of vaporized fuel needed is the same from one extreme of temperature to the other. But as the temperature is lowered, more liquid fuel must be injected to obtain this fixed vapor requirement. This is because temperature affects the vaporization of the fuel.

The required amount of prime is estimated by looking at the following gages:

- (1) Free Air Temperature: Tells the temperature of the air that will be

drawn into the engine during cranking and after starting. It aids in estimating the evaporating capabilities of the cold air stream.

- (2) **Carburetor Air Temperature:** Tells the temperature of the air in the duct, as well as some idea of the carburetor temperature and the contained fuel, and hence gives an idea of evaporating conditions.
- (3) **Oil Temperature:** Gives an indication of the stiffness of the engine; whether it has been in operation recently or not, if it has been warm or cold during storage. It also gives an idea of the temperature of the supercharger section and its ability to vaporize the first trickle of fuel.
- (4) **Cylinder Head Temperature:** Indicates the amount of heat available in the intake ports to vaporize the prime, also whether the fuel will be inclined to chill and collect on the cylinder walls.

Under extremely cold conditions, where priming before cranking is necessary, the amount of unvaporized fuel remaining after priming constitutes a serious "hydraulicking" hazard. The lowest temperature for obtaining dependable, safe starts, without pre-heating the engine is 0 F (-20 C). Oil dilution and a well developed technique are needed for starts under 40 F (5C). Even at this latter temperature, preheating of the engine is advantageous, if preheat is available, in order to reduce the amount of liquid fuel remaining after priming. (Priming systems are being developed for some engines which permit consistent starts at -20 F (-29 C) or lower without the use of preheat.) When the temperature is 0 F (-20 C) or less, consult section on "Cold Weather Operation."

a. Overpriming

With cylinder intake port priming, one serious result of overpriming, or of continued underpriming with unsuccessful attempts to start, is the presence of liquid fuel in the cylinders. This washes off the film of oil on the cylinder walls, pistons and piston rings. Without this lubrication there is a possibility of scor-

ing the cylinder walls and of piston seizure. If the engine has been overprimed it is essential that fresh oil be sprayed on the cylinder walls **before starting**. Dry cylinders may be indicated by a squeaking heard while the engine is being pulled through by hand.



In extreme cases the excess fuel will back up the intake pipes of the primed cylinders and flow into the intake pipes of the lower cylinders. This has been an all too frequent cause of "hydraulicking."

If the engine is allowed to stand after several unsuccessful attempts to start, in the course of which the engine has been overprimed, rusting of the cylinder walls and piston rings will occur unless a protecting film of oil is sprayed on these parts.

b. Underpriming

This condition usually results in weak firing which does not have sufficient energy to turn the engine over or else causes backfiring. If individual outlet exhaust stacks are used, there will be no evidence of fuel vapor in the exhaust outlets of the primed cylinders. In cold weather, fuel discharged from the fuel drain does not necessarily mean that the engine has been overprimed as only a small portion of the fuel will be vaporized.

c. Sources of Priming Fuel

Fuel for the priming system is commonly provided by:

- (1) Priming pump integral with carburetor (float type carburetor)
- (2) Hand plunger priming pump
- (3) Electric solenoid priming valve

- (1) **The priming pump which is integral with the carburetor** (the so-called self-priming carburetor) is actually the accelerating pump of the carburetor. Priming is accomplished as follows:

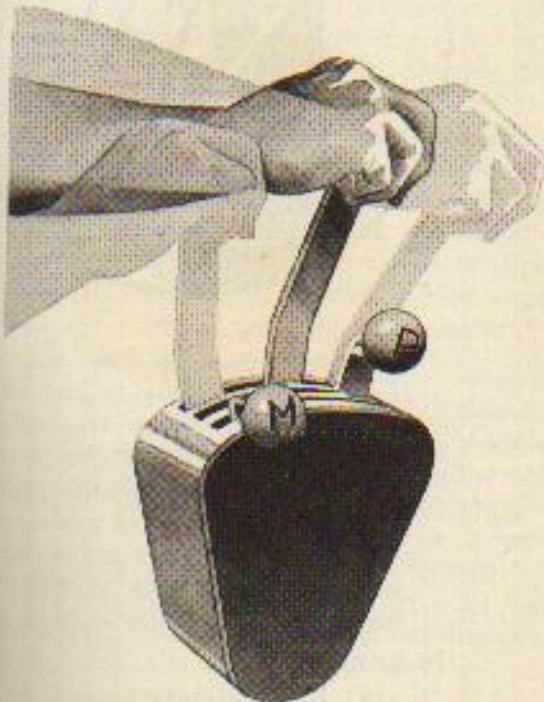

- (a) Place mixture control in full rich. This allows the carburetor bowl to be vented.
- (b) Raise fuel pressure to 3 psi. This fills the carburetor bowl with fuel. Greater pressure may cause the carburetor to overflow.
- (c) Move mixture control to full lean. This opens the passage from the accelerating pump to the primer distributor.
- (d) Move throttle backwards and forwards through its full travel. This pumps the fuel from the carburetor through the primer lines to furnish the

prime. The number of strokes of the throttle is dependent on the amount of prime desired.

- (e) Maintain fuel pressure 3 psi to refill the carburetor bowl with fuel after two or three strokes of the throttle.
 - (f) Return mixture control to full rich.
- (2) **The hand priming pump** is used in conjunction with engine installations equipped with either float or pressure injection carburetors. The



priming pump is a plunger type pump, and is usually located in the cockpit or possibly in the engine nacelle. The quantity of prime is gaged by the number of strokes made while priming.

To prime:

- (a) Mixture control in idle cut-off.

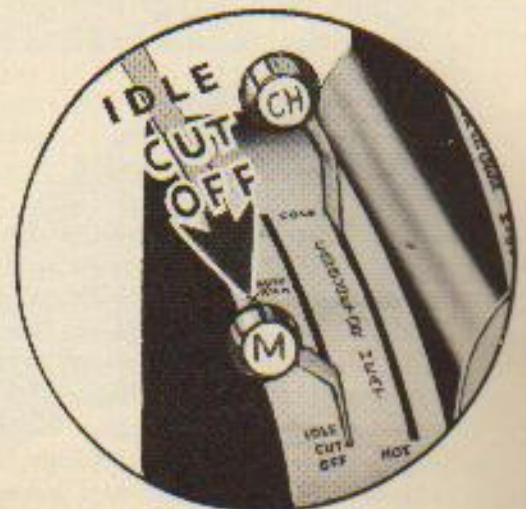

- (b) Raise 3 psi fuel pressure with wobble pump or turn on electric auxiliary fuel pump. Pressure is necessary to fill primer pump cylinder on the intake stroke.
- (c) While maintaining fuel pressure, draw plunger slowly out to ensure that the pump cylinder fills completely. Force plunger in rapidly in order to atomize the fuel effectively at the discharge nozzles. Prime the required number of strokes.
- (d) Return the plunger to the "Off" position, and make certain that it is fully locked.

- (3) The electric priming valve can be used with pressure injection carburetors, or with float carburetor installations if sufficient fuel pressure is available. The electric priming valve is usually attached to the

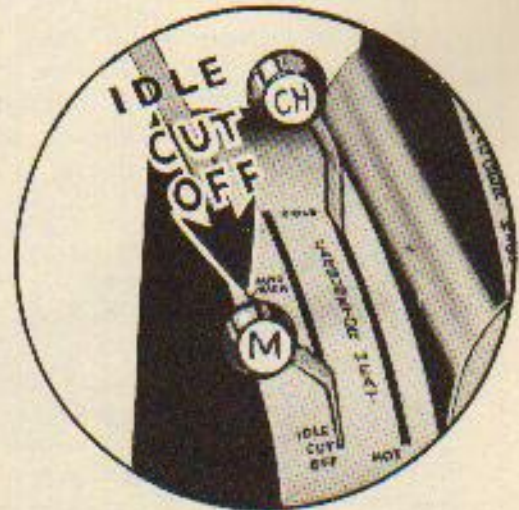

carburetor or some other source of fuel under pressure in the engine compartment. When the solenoid valve is opened, fuel under pressure is distributed through the priming system to the priming nozzles. The amount of prime is gaged by the pressure at the priming valve and the length of time it is held open.

To prime:

- (a) Keep mixture control in idle cut-off.
- (b) Raise the required fuel pressure with the wobble pump or the electric auxiliary fuel pump.

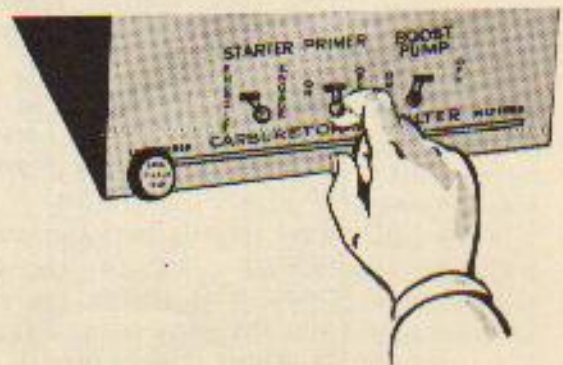
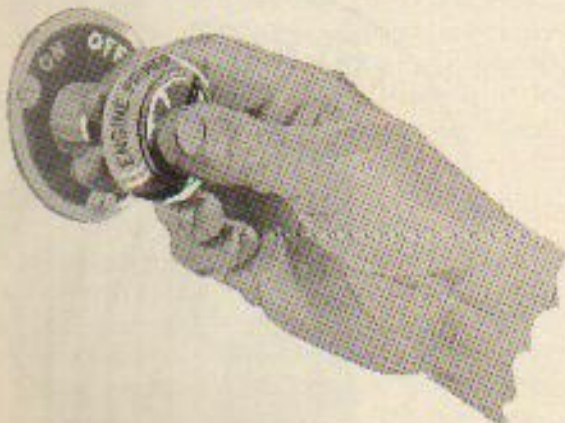
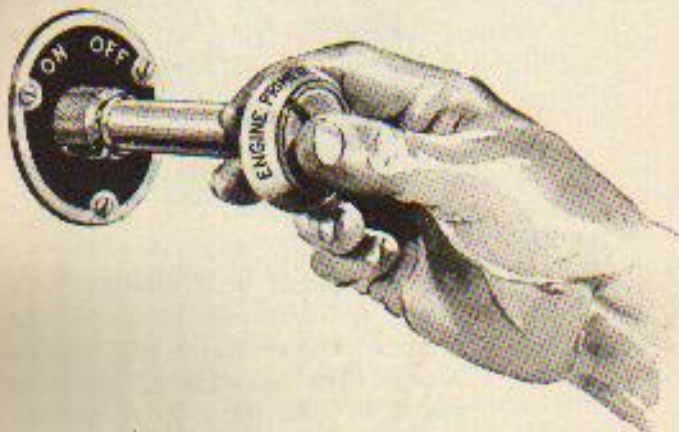

- (c) Close primer switch for required time which is dependent on temperature and the particular method of introducing the priming fuel into the engine.

The actual amount of prime is very difficult to define exactly. As previously pointed out, temperature is a large factor. With the electric priming valve, fuel pressure will affect the amount of actual prime discharged by the priming nozzles. With the self-priming carburetor and hand pumps, the manner of operating them will affect the total amount of prime delivered. In addition, the individual technique of the operator will affect the amount of priming desirable. One individual may go through the consecutive steps of starting with very exact timing, a minimum of lost motion and with a very small over-all time for the complete operation. Another individual may not perform the same procedure with the same degree of sureness. Consequently it is not feasible to draw up an exact table of priming requirements.

In general, with the carburetor integral primer no prime or one to two strokes may be required for a hot or warm engine, up to three or four strokes for a cold engine. Installations with a separate hand primer pump may require up to six or eight or more strokes for a very cold engine. However, this is dependent on the size of the hand pump, which often is of less capacity than those of the carburetor integral primers.

The electric priming valve discharge will vary with the fuel pressure and the system of introducing the fuel into the engine. Consequently the priming time will vary according to the particular engine being started.

6. IGNITION SWITCH

In the case of inertia or cartridge starters, the ignition must be turned on prior to starter engagement, as the full starting procedure must be completed while the starter energy is available. The direct cranking starter makes it possible to delay turning on the ignition until after the engine has been turned over two revolutions. This offers the opportunity to make certain that there is no excess liquid present to cause "hydrauliclocking." If, during these



two revolutions, the engine should appear to come against a definite abrupt stop, it may be concluded that the lower cylinders have accumulated liquid, and no further attempt should be made to turn the engine over until this liquid has been drained.

7. MIXTURE CONTROL

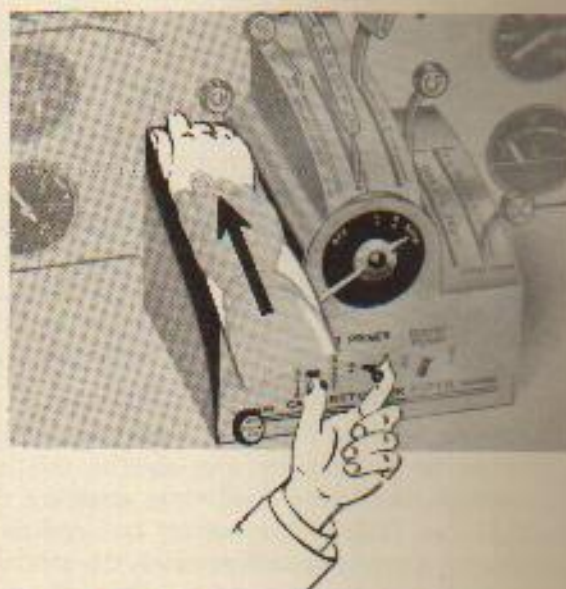

In the case of float carburetors, the mixture control is already in the automatic rich or full rich position when the starter is engaged, and no attention is required of this control as the engine starts.

With pressure injection carburetors, the start is made with the mixture control in idle cut-off so that fuel will not be discharged into the engine until needed. The proper timing of the mixture control move-

ment out of idle cut-off when starting often determines the success of the start. If the mixture control is moved into automatic rich before the engine has "caught," raw fuel is dumped into the engine before normal airflow is set up and the engine becomes loaded. As a general rule, firing of the engine should be of sufficient intensity to produce at least 350 or 400 rpm before the mixture control is moved to automatic rich. Moving the mixture control into automatic rich at the first sign of feeble firing or popping will usually be the cause of an unsuccessful start. However, with some priming systems, if movement of the mixture control is delayed too long after the engine is firing normally, the engine will have used up its prime and fail to start, and backfiring will often result. If the priming has been properly made there will be sufficient and proper strength fuel-air mixture in the engine to keep it turning over at sufficient speed until normal carburetion results from proper movement of the mixture control.

The operator must be ready to move the mixture control immediately back to idle cut-off in case the engine "dies" or shows signs of "dying," so that the discharge of fuel into the engine is stopped at once. Failure to do this has probably caused more "hydraulicked" engines than failure to clear out an engine before starting. In case there has been an excessive discharge of fuel into an engine that fails to run, clear out the engine by pulling the propeller through before attempting another start.

In the case of a "dying" engine, it may often be revived by moving the mixture control into idle cut-off, thus stopping the flood of fuel, and allowing the engine a chance to pick up, after which the mixture control may be returned to automatic rich.

8. OIL PRESSURE

As soon as the engine fires, the rpm should be held down to about 600 rpm until the oil pressure registers on the gage and it is certain that the engine is receiving oil. In many instances the oil pressure will not register immediately upon starting. In most installations 10 seconds without oil pres-



sure indication should not be exceeded. However, on some installations having long pressure lines, or pressure indicating transmitting systems, there may be a time lag requiring that this time limit be lengthened. It is imperative, however, that strict attention be given the oil pressure gage at this stage of the starting procedure, and the acquiring of this habit may some day pay dividends in saving an engine.

9. PROPELLER CONTROL

In the case of the Hamilton Standard counterweight type propellers, the control should be moved to the high rpm (low pitch) position after oil pressure is indicated.

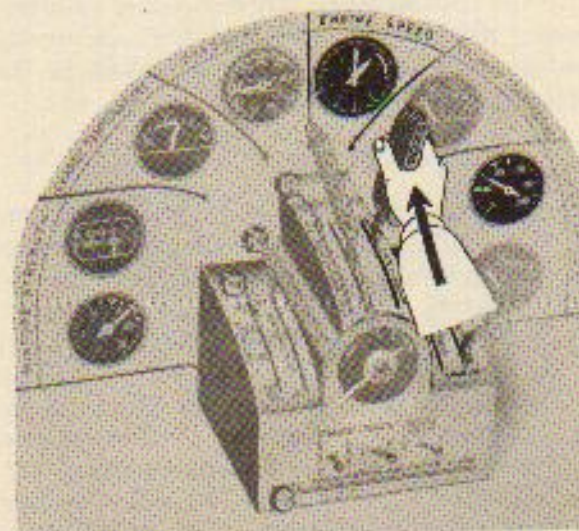

10. OVERLOADING OF ENGINE



Overloading of the engine with raw fuel is usually accompanied by a heavy discharge of fuel from the supercharger drain in warm weather or the presence of liquid fuel in the exhausts of the primed cylinders. Weak firing, followed by dense black smoke and possibly fire from the exhaust outlets, is also indicative of overloading.



11. "SAVING" THE START

In installations incorporating cylinder intake port priming and direct cranking starters, an opportunity is provided to "save" the start without the necessity of repeating the entire priming and or starting procedure.

- a. If the engine has been underprimed, additional fuel may be injected into the engine while cranking continues by moving the mixture control out of idle cut-off

for a brief interval as outlined in the starting procedure. (See page 67). This is the only instance where it is permissible to move the mixture control out of idle cut-off prior to actual engine operation, and the operator must use caution to ensure that the time limits indicated are not exceeded. Introduction of excessive fuel into the engine may cause "hydraulic" or overloading of the engine.

- b. If the start is not accomplished because of overloading, the fuel-air ratio may be leaned out by drawing more air into the engine. This is done by opening the throttle wide and keeping the mixture control in idle cut-off while cranking continues. As the fuel-air ratio leans out and passes through the combustible range, a start should be effected. In this case, immediate action on the part of the operator is required to retard the throttle so as not to overspeed the engine, and to move the mixture control to automatic rich to establish normal carburetion. It will be seen that the manipulation of the mixture control in the event of underpriming and of the throttle in the event of overloading is for the purpose of passing the mixture charge from one extreme of the fuel-air ratio toward the other so that a combustible range may be reached and a start effected.

In the case of inertia or cartridge starters, failure to prime properly must be corrected by clearing out the engine and repeating the complete starting procedure. Whether the failure to start has been due to underpriming or to overpriming, it is recommended that the engine be cleared out so that the operator will know the amount of prime that is in the engine at any one time.

The procedures just discussed, if followed as outlined, will result in a high percentage of successful starts. The percentage of successful starts will increase with experience, but there is always the chance of misgaging the effect of the many variables that must be taken into account. Failure to obtain a start results generally from underpriming or from overloading the engine by excessive priming.

GROUND OPERATION

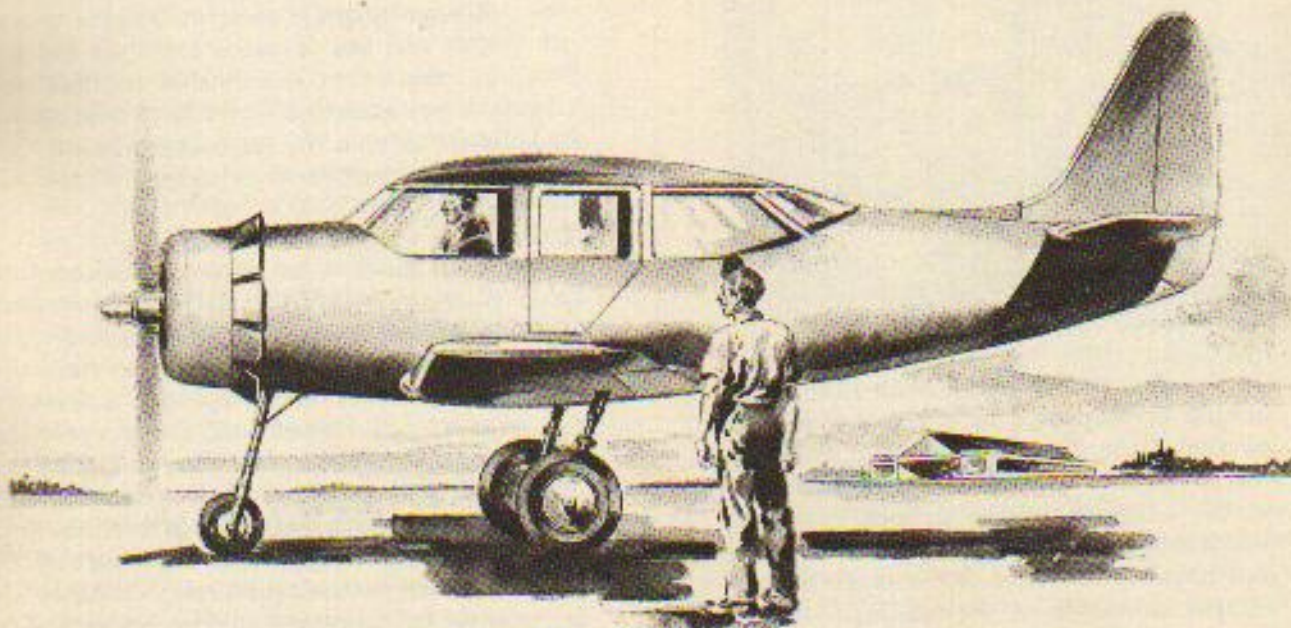

GENERAL

The similarity between the engine of an automobile and that of an aircraft has been discussed previously. It is well to forget this relationship when forming habits of aircraft engine operation. It is not by any means unsafe to start a cold automobile engine, pull away from the curb and drive away. A few blocks of slow, restrained running will suffice to warm the engine to the point where it will "take" the accelerator and function normally. As long as no attempt is made during the early stages to cross tracks in front of trains or to perform fancy traffic maneuvers in the wrong lane, the car and driver will be looked upon with favor by the insurance company. The automobile does not depend upon its engine for sustentation.

At the instant the airplane leaves the ground and until it is in full flight and clear of obstacles, it is entirely dependent upon its engine. As the airplane pulls away from its "curb", the engine must deliver its maximum rating without hesitation. There is no possible means of getting under way slowly and warming up in the air. It is essential then to take what time is necessary to bring the engine into a condition where it can safely deliver its per-

formance and to make such checks as will give assurance of satisfactory functioning. A cold engine is not a dependable engine.

WARM-UP

After starting, several minutes will be spent in warming up the engine. This is done at 1000 rpm* with the propeller in the high rpm (low pitch) position. One thousand rpm is specified as this engine speed will ensure freedom from spark plug fouling. The propeller pitch position results in the lightest possible load at this rpm.

If power were applied to a cold engine there would be an unsatisfactory response for three reasons:

- a. **Oil:**—Cold, undiluted oil is too thick to flow through the various lubrication passages, and vital engine parts would be starved for lubrication even though a high pressure showed on the oil pressure gage. The oil must be not less

*1000 rpm is recommended as the warm-up rpm for current Pratt & Whitney engines which have take-off rpms ranging from 2250-2800. A more general rule would be to warm up at 40% of the engine speed obtainable with the wheels against the blocks and with the propeller in fixed low pitch. For example:

Take-Off rpm		Warm-Up rpm
3300	× .40 =	1320
2000	× .40 =	800

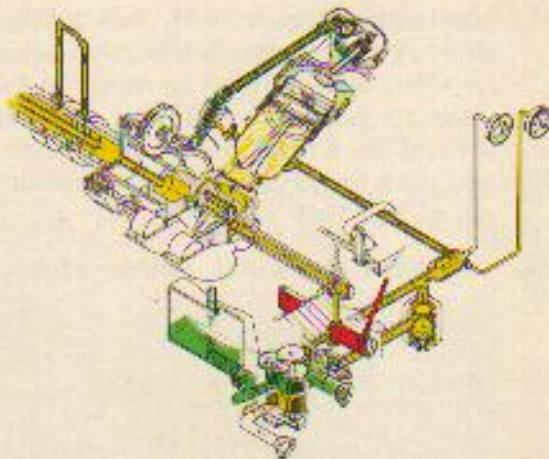

than 100F (40C) before increasing engine speed above the warm-up rpm.

- b. **Induction System:**—Engine performance and operation are sensitive to the temperature of the induction passages.

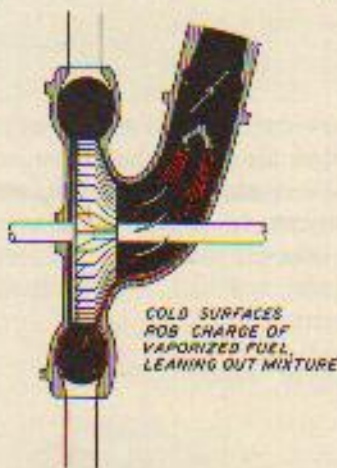

An intake charge cannot hold all its fuel when it comes in contact with cold metal surfaces, and this leaning-out will cause the engine to hesitate and run raggedly.

- c. **Even Expansion of Entire Engine:** — The engine designer has established the clearances between the working parts after considering the effects of expansion when the material has warmed up. In many instances the cold clearances are not sufficient to allow satisfactory oil flow. Because many major parts are made from dissimilar metals, they must be brought up to operating temperature in order that the uneven rates of expansion, that have been taken into account in

the design, are properly adjusted. The entire mass of metal must be in the working temperature range to have a harmonious relation between the individual parts.

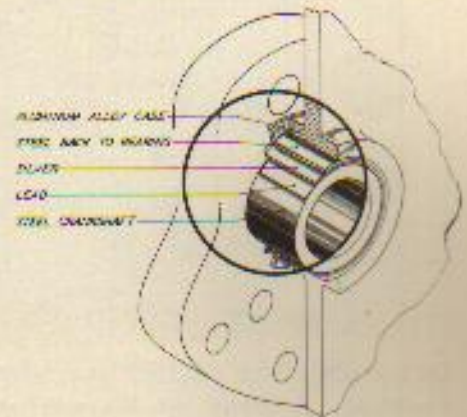

In general, oil temperature is the most direct gage of the temperature condition of the entire engine. If time has been taken to bring the oil temperature up to 100F (40C) at 1000 rpm with the propeller in high rpm position, the minimum requirements of a proper warm-up will be met. Where practical, an oil inlet temperature of 140-165F (60-75C) should be reached.

1. **Cowl Flaps**

Do not close the cowl flaps to accelerate the warm-up, regardless of outside air temperature or the indication of the cylinder head gage. The heated air collecting around the exhaust system will be confined in the area adjacent to the ignition leads. For the protection of the ignition system, it is essential that the cowl

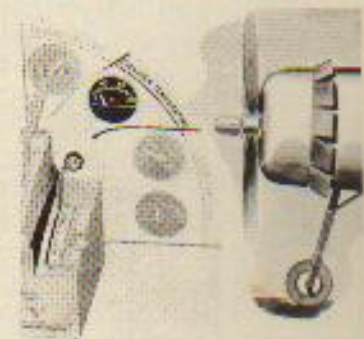

flaps remain wide open at all times that the engine is running on the ground, and for a cooling-off period after the engine is stopped.

2. Mixture

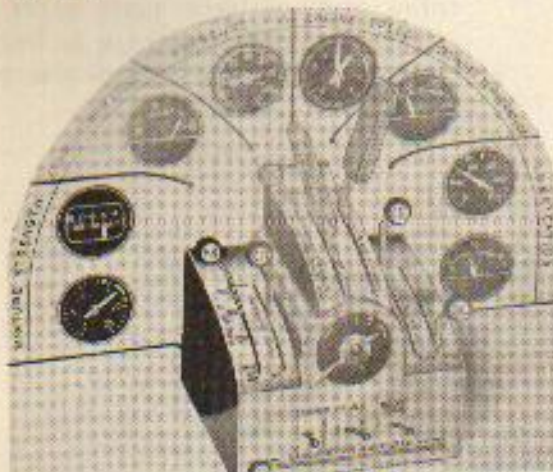

Do not use a lean mixture to accelerate the warm-up. Actually, at the warm-up rpm there is practically no difference in the mixture supplied to the engine whether the mixture is in a lean or rich position, as metering in this power range is governed by the throttle position.

As there is no occasion while on the ground to use a lean mixture position, it is imperative that the mixture control remain in the rich position to make sure that it will not be inadvertently forgotten prior to take-off.

Engine exhaust smoking, while running with closed throttle, should be eliminated by proper idle adjustment, thereby preventing fouled plugs.

3. Carburetor Heat

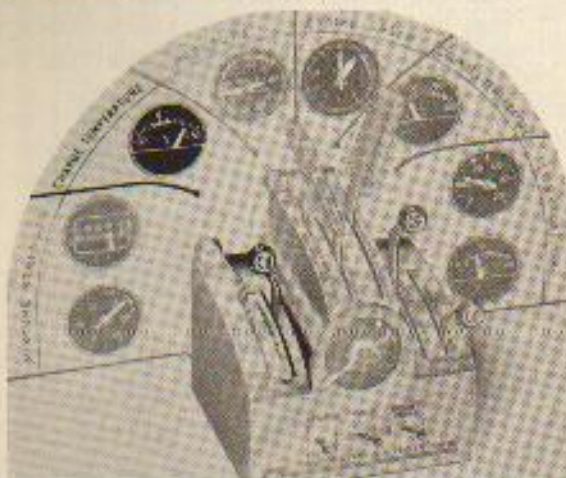

Carburetor heat can be used as required under conditions leading to ice formation. In the case of engines equipped with float

type carburetors or with fuel nozzles located at some distances upstream from the impeller, it is desirable to raise the carburetor air temperature during warm-up to prevent ice formation, to assist distribution, and to ensure smooth operation. Do not exceed 100F (40C).

4. Carburetor Air Filter (where applicable)

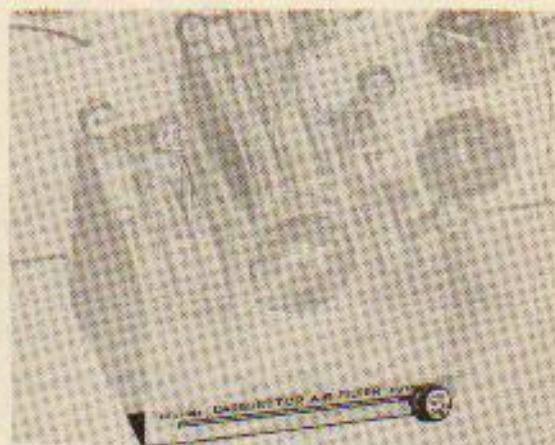

Where dust conditions are present the carburetor air filter should be used. As soon as the engine has started, the air should be drawn in from this source until after the take-off has been performed and an altitude reached where dust-free air is present.

5. Magneto Safety Check

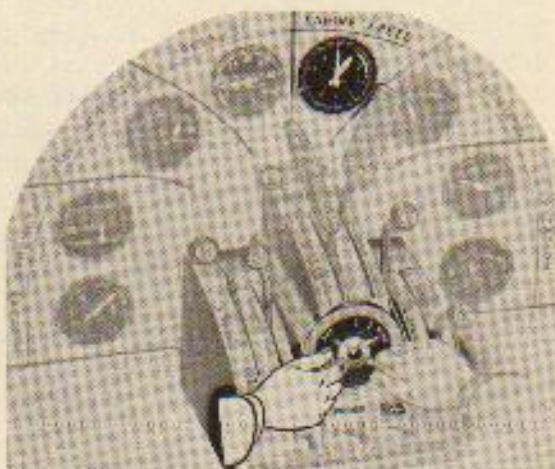

During the warm-up running, the magneto safety check can be performed. Its purpose is to ensure that all ignition connections are secure and that the ignition system will permit operation at the higher power used in the ground check to be con-

ducted later. The magneto safety check is conducted as follows:

- (1) Rpm — 1000
- (2) Propeller — High rpm (low pitch)

All other controls the same as during warm-up

- (3) Switch — From "Both" to "Right" and return to "Both"
- (4) Switch — From "Both" to "Left" and return to "Both"
- (5) Switch — From "Both" to "Off" momentarily and return to "Both"

While switching from "Both" to a single magneto position, for example from "Both" to "Right," a slight but noticeable drop in rpm should occur. This indicates that the opposite magneto has been properly grounded out and that the connection to the single operating magneto is secure. Complete cutting out of the engine when switching from "Both" to "Off" indicates that both magnetos are properly grounded. Failure to obtain any drop while in the single magneto position, or failure of the engine to cut out while switching to "Off," indicates that one or both ground connections are not secured. The time required for proper warming-up gives ample opportunity to perform this simple check which may disclose a condition which would make it inadvisable to continue operation until after corrections have been made.

6. Ground Check

After the engine has been given sufficient low power running to make certain that all parts are ready to work together, it should be able to deliver take-off power with ample reliability—and probably will. However, there are a few questions that most pilots will wish to have answered before they commit themselves to complete dependence on their powerplant during the take-off, for example:

- (a) Is the engine in proper mechanical condition?
- (b) Is the oil system functioning at the required pressure?
- (c) Is the ignition system performing properly?

- (d) Is the fuel system delivering fuel to the engine at the required pressure?
- (e) Are the propeller and supercharger shift mechanisms and other accessories functioning properly?

The answers to these questions are learned in the course of the ground check.

A standard ground check is performed as follows: The aircraft should be headed into the wind, if possible, to take advantage of this cooling airflow.

7. Control Position Check

Cowl Flaps	— Open
Mixture	— Rich
Propeller	— High rpm
Carburetor Heat	— Cold
Carburetor Air Filter	— As required
Supercharger Control	— Low, Neutral, or Off
Position (where applicable)	

Procedure

1. Check propeller according to propeller manufacturer's instruction.
2. Open throttle to manifold pressure equal to field barometric pressure
3. Switch from "BOTH" to "RIGHT" and return to "BOTH."
Normal drop — 50-75 rpm*
Maximum drop — 100 rpm*
4. Switch from "BOTH" to "LEFT" and return to "BOTH"
Normal drop — 50-75 rpm*
Maximum drop — 100 rpm*
Maximum difference between "RIGHT" and "LEFT" — 40 rpm*
5. Check:
Fuel pressure — 17 psi*
Oil pressure — 85 psi*
6. Note rpm
7. Retard throttle

NOTE: Additional features, such as multiple speed or multiple stage superchargers, require ground checking. The resulting changes in the above basic procedure will be explained in the supplements describing the operation of these special items.

In addition to the operations outlined above, the functioning of various items of airplane equipment will be checked in an appropriate order.

*These quantities are for illustration. Consult the specific operation instructions for values applying to a particular engine.

DISCUSSION

1. Propeller Check

The propeller check is performed to ensure proper operation of the pitch control and the pitch change mechanism. Each type of propeller requires a different procedure, and the applicable manufacturer's instructions should be followed.

2. Rpm and Manifold Pressure

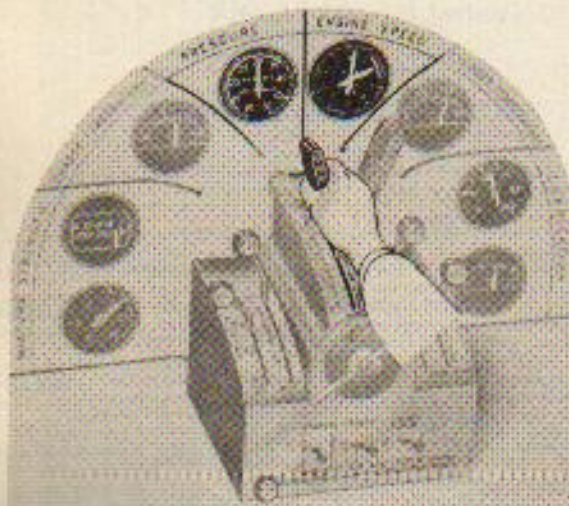

Specific check of rpm and manifold pressure relationship should be made during each ground check. This may be done at the time the engine is run-up to make the magneto check. The basic idea of this check is to measure the performance of the engine against an established standard. Calibration tests have determined that the

engine is capable of delivering a given power at a given rpm and manifold pressure. The original calibration, or measurement of power, is made by means of a dynamometer. During the ground check, measurement of power is made with the propeller. With constant conditions of air density, the propeller, at any fixed pitch position, will always require the same rpm to absorb the same horsepower from the engine. This characteristic is used in determining the condition of the engine. Any increase in manifold pressure required to obtain the same rpm, or conversely, the inability to obtain the check rpm with the check manifold pressure, is an indication that the engine is not giving the performance of which it is capable. Variation in altitude of the fields on which the check is made will result in varying manifold pressures for a given rpm as is indicated in Fig. 28.

Before starting the engine, observe the manifold pressure gage. This gage will read approximately the atmospheric (barometric) pressure when the engine is not running. At sea level this is approximately 30 in. Hg and at fields above sea level the atmospheric pressure will be less, depending on height above sea level.

When the engine is started and is accelerated the manifold pressure will fall off until about 1600 or 1700 rpm is reached when it will begin to rise. At approximately 2000 rpm, with the propeller in

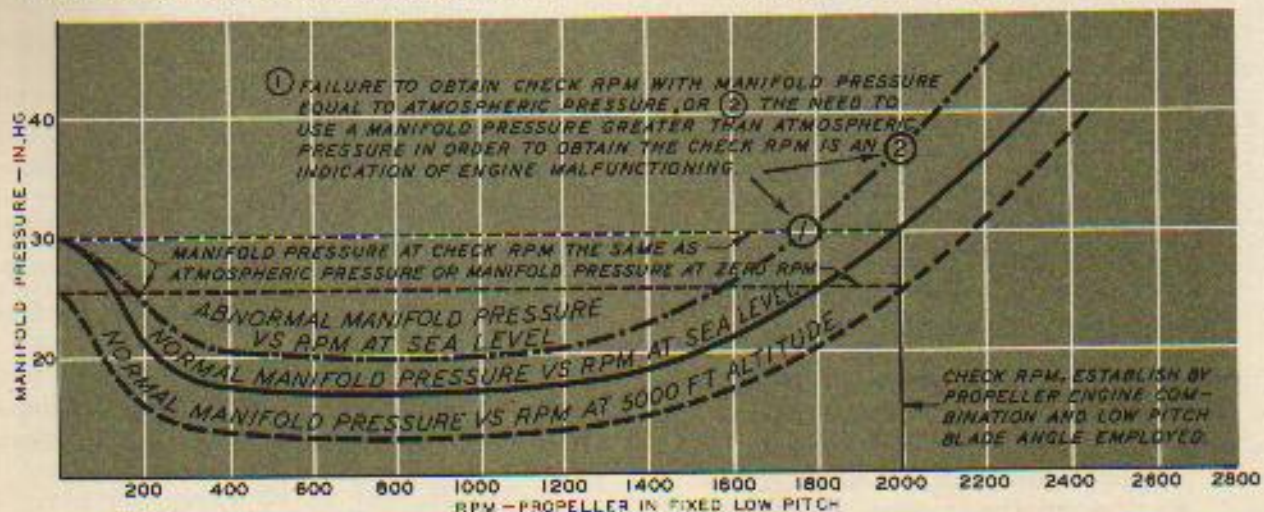
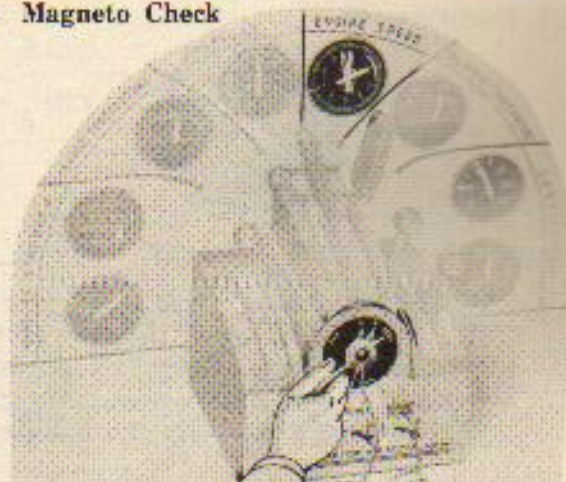

Fig. 28 - Manifold Pressure vs Rpm - Propeller in Fixed Low Pitch

fixed full low pitch position, the manifold pressure should be the same as the atmospheric pressure. That is, if the manifold pressure gage reading (atmospheric pressure) is 30 in. Hg before starting the engine, the pressure reading should return to 30 in. Hg at approximately 2000 rpm, or, if the manifold pressure gage reads 26 in. Hg before starting, it should read 26 in. Hg again at approximately 2000 rpm. The exact rpm may vary with various models of engines or because of varying propeller characteristics. In certain installations the rpm needed to secure a manifold pressure may be as high as 2200 rpm. However, once the required rpm has been established for an installation, any appreciable variation therefrom indicates malfunctioning. This may be because the low pitch stop of the propeller has not been properly set or because the carburetor or ignition system is not functioning properly. The accuracy of this check may be affected by the following variables:

- a. Wind: — Any appreciable air movement (5 miles per hour or more) will change the air load on the propeller blade when it is in the fixed pitch position. A head wind will increase the rpm obtainable with a given manifold pressure. A tail wind will decrease the rpm.
- b. Atmospheric Temperatures: — The effects of variations in atmospheric temperature tend to cancel each other. Higher carburetor entrance and cylinder temperatures tend to lower the rpm, but the propeller load is lightened because of the less dense air.
- c. Engine and Induction System Temperature: — If the cylinder and carburetor air temperatures are high because of factors other than atmospheric temperature, a low rpm will result as the power will be lowered without a compensating lowering of the propeller load.
- d. Oil Temperature:—Cold oil will tend to hold down the rpm as the higher viscosity results in increased friction horsepower losses.

3. Magneto Check



In performing the magneto check the power absorbing characteristics of the propeller in the low fixed pitch position are utilized. In switching to individual magnetos the cutting out of the opposite plugs results in a lower rate of combustion which gives the same effect as retarding the spark advance. The drop in engine speed is a measure of the loss of power attendant on this lower combustion rate. By comparing the rpm drop-off with a known standard the following are determined:

- a. Proper timing of each magneto.
- b. General engine performance as evidenced by smooth operation.
- c. Additional check of the proper connection of the ignition leads.

Any unusual roughness on either magneto is an indication of faulty ignition caused by plug fouling or by malfunctioning of the live side of the ignition system. The operator should be very sensitive to engine roughness during this check. Lack of a drop-off may be an indication of faulty grounding of one side of the ignition system. Complete cutting out when switching to one magneto is definite evidence that its side of the ignition system is not functioning.

Excessive difference in rpm drop-off between the left and right positions can indicate a difference in timing between the left and right magnetos. Inasmuch as Pratt & Whitney Aircraft models use the same spark advance for both sides of the ignition system, such a condition should be corrected.

4. Fuel Pressure



FUEL PRESSURE

The fuel pump relief valve is set to give normal flight pressure at the rpm of the ground check. Satisfactory fuel pressure indication at this time is assurance that the fuel system is properly functioning.

5. Oil Pressure



OIL PRESSURE

The oil pressure relief valve is set to give a standard oil pressure at the rpm of the ground check and with a specified oil temperature. Satisfactory indication of oil pressure at the specified temperature is assurance that adequate oil pressure will be available for the operating range.

6. Cylinder Temperatures

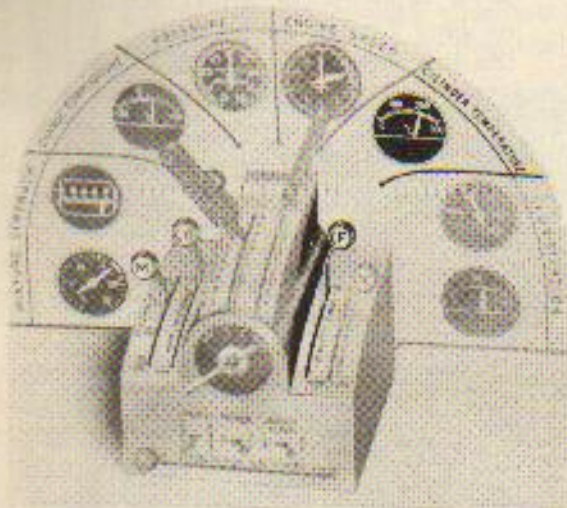

Little, if any, cooling airflow is available on the ground, and operation at greater

than warm-up rpm must be kept to a minimum, especially if the aircraft is not headed into a good wind. It is essential that cylinder head temperatures never exceed the maximum specified for continuous operation, and it is desirable to keep them at least 50F (30C) below the maximum continuous limit. It must be remembered that the head temperature indicator is connected to one cylinder only. This cylinder is selected on the basis of flight conditions, and often will not be the hottest cylinder during ground operation.

7. Idle Mixture Setting

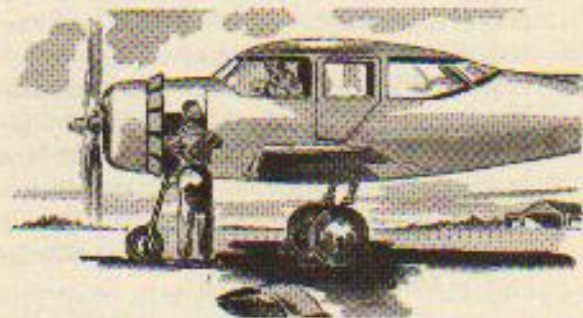

Plug fouling difficulty is the inevitable result of failure to provide proper idle mixture setting. The tendency seems to be to adjust the idling mixture on the extremely rich side and to compensate for this by adjusting the throttle stop to a relatively high rpm for minimum idling. With a properly adjusted idle setting it is possible to run the engine at 450 rpm or even less for long periods with complete freedom from plug fouling. Such a setting will result in a minimum of plug fouling, exhaust smoking, and loading up; and will pay dividends from the saving on the airplane brakes after landing and while taxiing.

If the wind is not too strong, the check of the idle mixture setting can easily be performed during the ground check as follows:

- a. Close throttle
- b. Move mixture control toward idle cut-off and observe change of rpm
- c. Move mixture control back to automatic rich before engine cuts off

As the mixture control lever is moved toward idle cut-off, and before normal drop-off, one of two things may occur momentarily:

- (1) The engine speed may increase by as much as 200 or 300 rpm. An increase of not more than 20 rpm indicates proper mixture strength. A greater increase indicates that the mixture is too rich, as the engine accelerates while the mixture leans out through best power.
- (2) The engine speed may not increase, or may drop immediately. This indicates that the idle mixture is too lean, as the fuel-air ratio has straightway leaned out beyond best power.

The idle mixture should be set to give a mixture slightly richer than best power resulting in a 10 to 20 rpm rise after idle cut-off.

This check should be performed with the idling speed set for 450 to 500 rpm. If the rpm is higher, correct idling adjustment will not result. In addition, the engine cylinder and oil temperatures should be at a stabilized value representing the normal temperatures at which the engine will operate at this rpm.

This check should be performed frequently and necessary adjustments made on new installations, as the diaphragms of new carburetors may not have soaked for a sufficient length of time to obtain their final flexibility. As they become more pliable the idle mixture setting must be adjusted to maintain the desired idling. After the diaphragm has become soaked to a permanent condition it is desirable to check the idling mixture setting regu-

larly to ensure proper ground and flight idling.

NOTE: This check must be performed in still air conditions. Any considerable wind, whether head or tail, or across the airplane, will affect the results.

Since the metering of the fuel by the carburetor in the idle range is not compensated for altitude, it follows that an idle mixture setting correctly adjusted for one field may not give satisfactory results at some other field of different altitude. If the mixture is correctly set for the lower of two fields, it will tend to be too rich at the higher field; if correctly set for the higher field, it will be too lean for the lower. In the case of an airplane whose flight schedule calls for stops at several fields of different altitudes, it will generally be found possible to make some compromise, intermediate idle mixture setting which will give satisfactory, if not perfect, results at each of the various fields. The tendency of the mixture to be too rich at altitude, and hence to "torch" and to foul the spark plugs, may be offset by idling at speeds slightly higher than normal.

8. Taxiing

Use a smooth flow of power or smooth changes of power during taxiing. Rapid and frequent "jazzing" sometimes interferes with the operation of the accelerating pump, with the result that backfires occur because of the low manifold pressures just after a sharp closing of the throttle, while the engine is still turning at a high rpm.



COLD WEATHER OPERATION

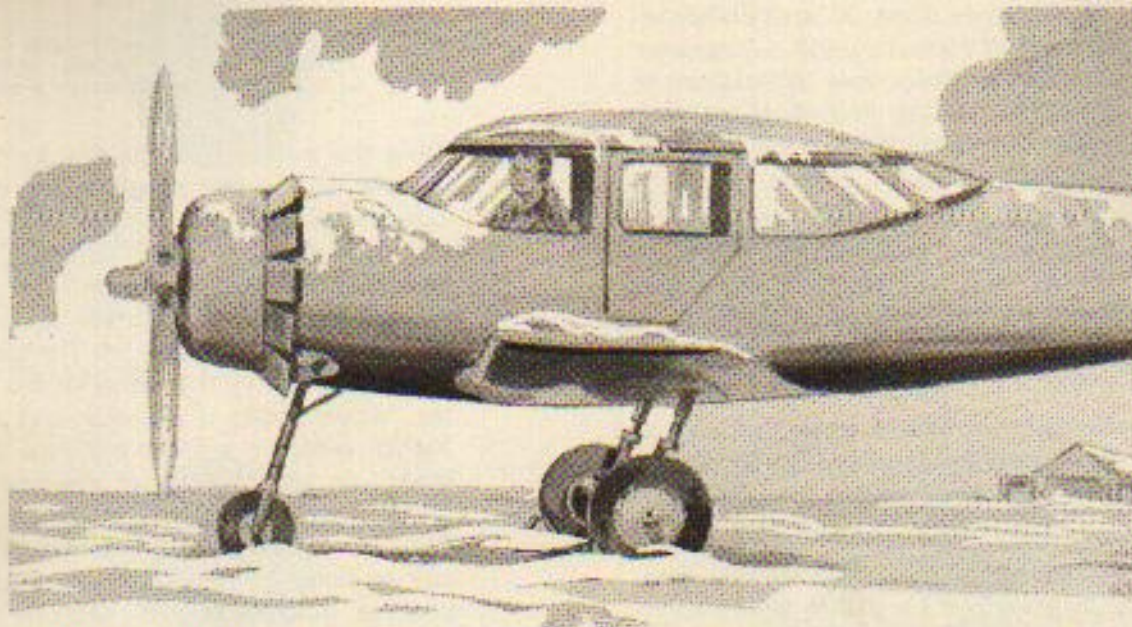

Cold weather operation of the aircraft engine involves conditions that require special preparations and precautions as compared to normal weather operation. Vaporization of the fuel becomes difficult, and the high viscosity of the oil causes reduced cranking speed with accompanying high loads on the starter and batteries. Often the accessories fail because of congealed oil. Excessive cylinder priming washes the oil from the piston rings and cylinder walls causing piston scuffing and scoring of the cylinders, while fuel may collect in the bottom intake pipes to cause hydrauliclocking.

PREHEATING

Approximately 0 F (-20 C) is the lowest temperature at which engine starting can be accomplished using the standard priming system, accessories, and batteries. (Priming systems are being developed for some engines which permit consistent starts at -20 F (-29 C) or lower without the use of preheat.) Successful starting at this temperature is contingent on adequate oil dilution, sufficient cranking speed, and proper technique. Inexperienced personnel will require considerable practice before achieving dependable starting at 0 F (-20 C). Very capable personnel, using the conventional starting procedure, have made starts at much lower temperatures, occasionally as low as -35 F (-37 C). However, this practice is not recommended for general use because of the likelihood of hydraulic-

locking and piston scuffing from the large amount of priming necessary, and the possible failure of the lubrication system or accessories. Therefore, the engine and installation should be preheated when ground temperatures are below 0 F (-20 C), unless the engine and installation are warm from recent operation, or have priming systems that permit lower temperature starts. Adequate oil dilution is necessary to ensure the required crankability for these improved priming systems.

If oil dilution was not employed when the engine was previously shut down, external heat generally will be necessary at temperatures below 40 F (5 C). Past experience, "stiffness" of the engine, and fluidity of the oil at the Y-drain valve will be the best indications of the necessity for preheat.

One suggested means of using engine covers and ground heating equipment for preheating the power plant is shown on page 93. In an installation of this kind, there are two regions which must be heated. The most important is the accessory compartment of the nacelle, the region aft of the diaphragm or accessory cowl. In this compartment are located various accessories, such as the starter, generator, fuel pump and the principal parts of the oil system. Frequent failures during or after starting occur in the accessory compartment when preheating is inadequate.

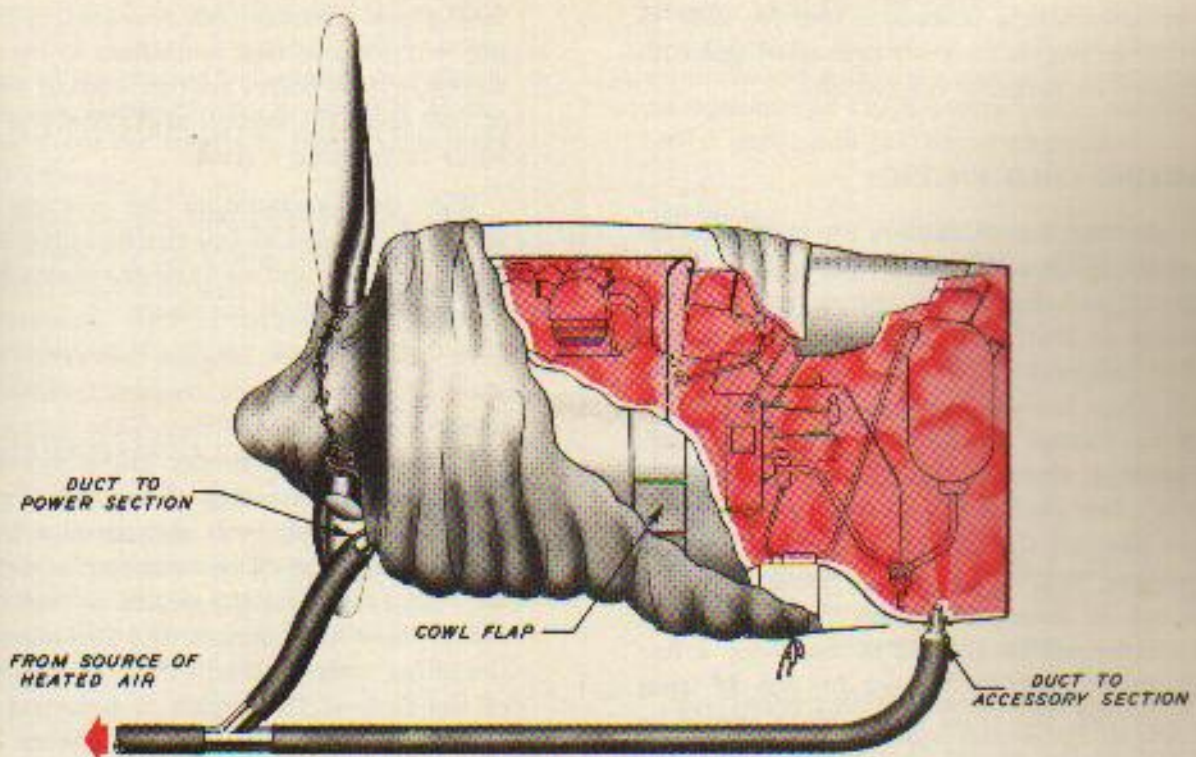

The second region in the nacelle which must be heated is forward of the diaphragm. The power section of the engine is included in this space.

The minimum time required for heating an engine is dependent upon the capacity of the heater, the size of the engine, the outside air temperature, and the amount of oil dilution used prior to the previous shutdown. For example, a heater delivering from 75,000 to 90,000 Btu per hour will require about 30 minutes to heat a Twin Wasp engine at -30 to -40 F (-35 to -40 C) outside air temperature. With the same heater and same temperature, a minimum of 45 minutes will be required with a Double Wasp engine. The difference lies in the amount of metal in the engine which must receive heat. With strong ground winds or lower outside temperatures, increased minimum heating time will be necessary. It is desirable to heat the power plant for a longer period than the minimum to ensure the easiest possible starting consistent with the time available for heating. When using preheat, care must be exercised not to burn the insulation of the ignition system, if the temperature of the preheat air exceeds 225 F (110 C).

The successful completion of preheating can best be determined by turning the propeller occasionally and noting engine "stiffness." This is particularly effective if no, or insufficient, oil dilution has been used. With extreme oil dilution, an engine will be free at a temperature as low as -50 F (-45 C). Cylinder head temperatures, as indicated by the cockpit gage may not give the true cylinder head temperatures, if the preheated air happens to discharge directly in contact with the thermocouple. Checking the fluidity of the oil at the Y-drain can be used as a supplementary check. This will also indicate the presence of ice which would block the flow of oil to the engine.

If the oil was drained after the previous flight, it should be preheated to a temperature of at least 150 F (65 C) before being returned to the aircraft oil system. Engine heating should be completed before the heated oil is returned.

To ensure adequate voltage for the engine starter, warm and fully charged batteries should be installed and connected to the electric system at this time. If the aircraft is equipped with an auxiliary power plant, the latter should be started, or a ground source of auxiliary power connected to the aircraft electrical system.

Normal starting procedure may be used in starting an engine properly preheated and with preheated or properly diluted oil.

STARTING COLD ENGINES

In starting a cold engine, ice may form on the spark plugs and on other parts of the combustion chamber after one or more unsuccessful attempts to start. The "ice" is a combination of fuel, oil and water, and will prevent the spark plugs from firing. Every effort must be made to "catch" the engine on the first starting attempt, since ice will form in the cylinder within a few seconds after it has fired and quit. If two or three starting attempts have resulted in nothing but a few feeble firing impulses, time can be saved and abuse to the batteries and starter can be avoided by removing a few front spark plugs to inspect for ice. If icing has occurred, the front spark plugs should be changed or the engine thoroughly heated before making further attempts to start.

With the electric inertia or combination inertia-direct cranking starter types, be sure to energize the starter completely before engaging.

Engine priming is dependent upon the type of priming system and the amount of preheat which have been used, and on other factors that have been discussed elsewhere under "Priming". With sufficient preheat a normal warm engine start may be made.

With pressure injection carburetors, after engaging the starter, move the mixture control slowly out of idle cut-off as soon as the engine is firing on the prime, but be prepared to return it to idle cut-off quickly if the engine quits. Particularly with a stiff engine, it is very easy to get the mixture too rich for running and the engine will not pick up speed. Therefore, brief periods during which the mixture control is moved back to the idle cut-off may be used to advantage until engine speed increases enough so that airflow is sufficient to match the fuel flow.

Caution must be used to avoid introducing excessive amounts of raw fuel to the lower in-

take pipes. Frequent instances of hydraulic-licking will occur if this precaution is overlooked. Except with a warm engine, a small discharge of fuel from the supercharger drain is normal while attempting a start.

With float carburetors the mixture control will be positioned in full rich or automatic rich when starting, and no further manipulation of this control will be necessary.

In cold weather, engine operation immediately after starting is frequently rough, with back-firing and after-firing. This is due principally to a lean carburetor idling mixture and to reduced vaporization of the fuel. Fouled or "iced" spark plugs will also produce the same effects. As a corrective, turn on the carburetor air heat as soon as the engine is free of back-firing. This will increase the fuel-air ratio in the idling range and will improve vaporization of the fuel. If the engine is equipped with a blower-rim or blower-throat priming system, the intermittent use of priming will assist in preventing backfiring until sufficient heat is available and carburetor air heat can be used. After the engine has warmed up operation will be satisfactory with cold air.

WARM-UP

No attempt must be made to heat the engine rapidly after starting by closing the cowl flaps. As in normal weather, keep the cowl flaps fully open at all times on the ground. Cylinder temperatures are not as important as oil temperatures, which represent the temperature of the internal engine parts. Cylinder temperatures will rise quite rapidly to temperatures only slightly below normal. Consequently the principal problem in warm-up is to increase the oil temperature. Until the oil temperature increases to 140 F (60 C), keep manually controlled oil cooler flaps fully closed.

In the case of engines that have had the oil diluted with fuel, it is preferable to allow the oil temperature to rise considerably above 140 F (60 C), and increase the engine speed during warm-up to 1200-1400 rpm. Very little gasoline is driven out of the circulating oil below this oil temperature and engine speed. As much of

the engine. Some of the diluted oil will also find its way outside the hopper and will collect on top of the undiluted oil in the main tank.

The amount of oil dilution necessary is dependent upon the expected temperature to be protected against. Oil dilution is recommended when the expected starting temperature is 40 F (5 C) or lower. The elapsed time required to dilute to a desired percentage depends on two factors; the rate of flow of gasoline into the oil, and the amount of oil to be diluted. This fact explains the difference in time interval required for various aircraft. It will be necessary for the operator to consult the manufacturer's specific instructions for the aircraft concerned.

Oil dilution is accomplished just before shutting down the engine. Before beginning oil dilution the engine should be idled, if necessary, to reduce cylinder head temperatures to a maximum of 300 F (150 C), and allow the oil temperature to fall below 120 F (50 C). While idling the engine, close the oil dilution switch for the required time. Keep the switch closed while stopping the engine, and until it has stopped turning over. If it is necessary to service the oil tank, this should be done prior to starting dilution.

In extreme weather conditions, it is necessary to dilute the oil going into the Hydromatic propeller by "exercising" the propeller governor control during the latter part of the dilution time interval. This must be done when the engine is briefly brought up to 1500 or 1600 rpm so that the governor will operate. Oil operated supercharger controls require the same treatment under these weather conditions.

The introduction of gasoline into the lubricating oil will loosen carbon and sludge deposits within the oil system. This carbon and sludge is carried to the engine oil screen and collects there in quantities sufficient to cause the collapse of the screen. Consequently, within an hour or two after the dilution is first used in the season, the screen must be removed for inspection and cleaning. This inspection must be repeated at short intervals until sludge and carbon no longer collect. Should this precaution be overlooked, collapsed screens are certain to result. Trouble with dislodged carbon may also be encountered if dilution is not used almost daily following its first use in the season. Some northern operators use small amounts of oil dilution throughout the warmer weather to keep the oil system cleared of carbon and sludge.

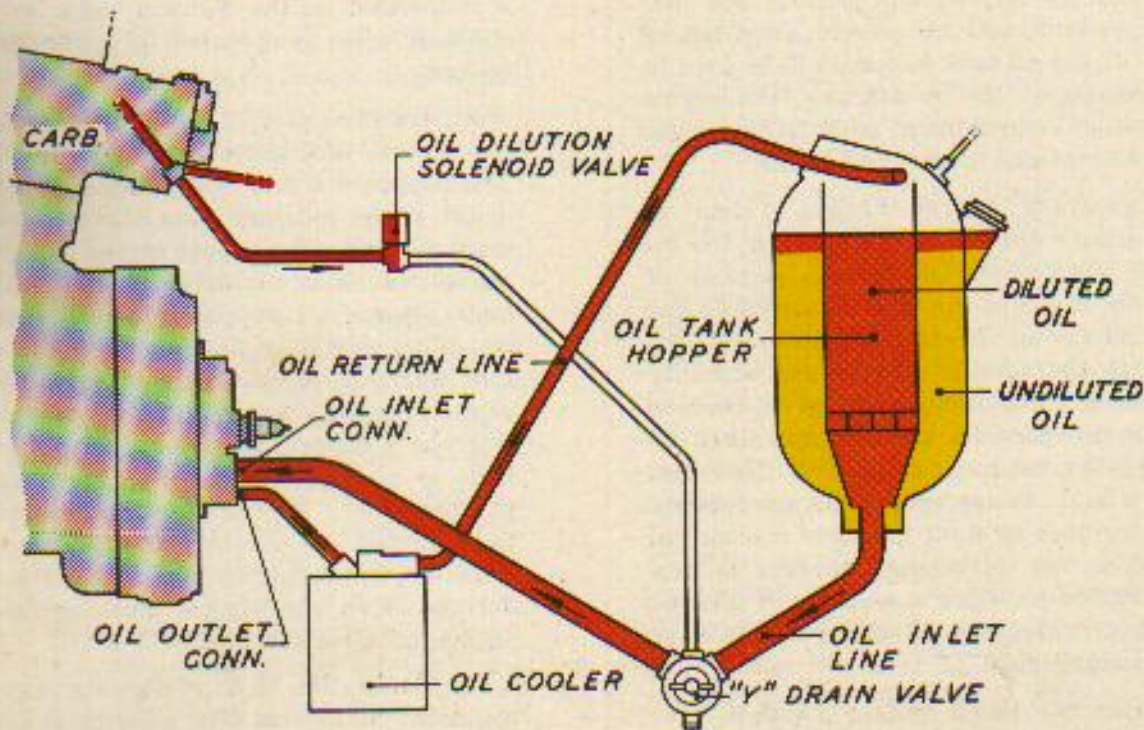

Dilution Completed

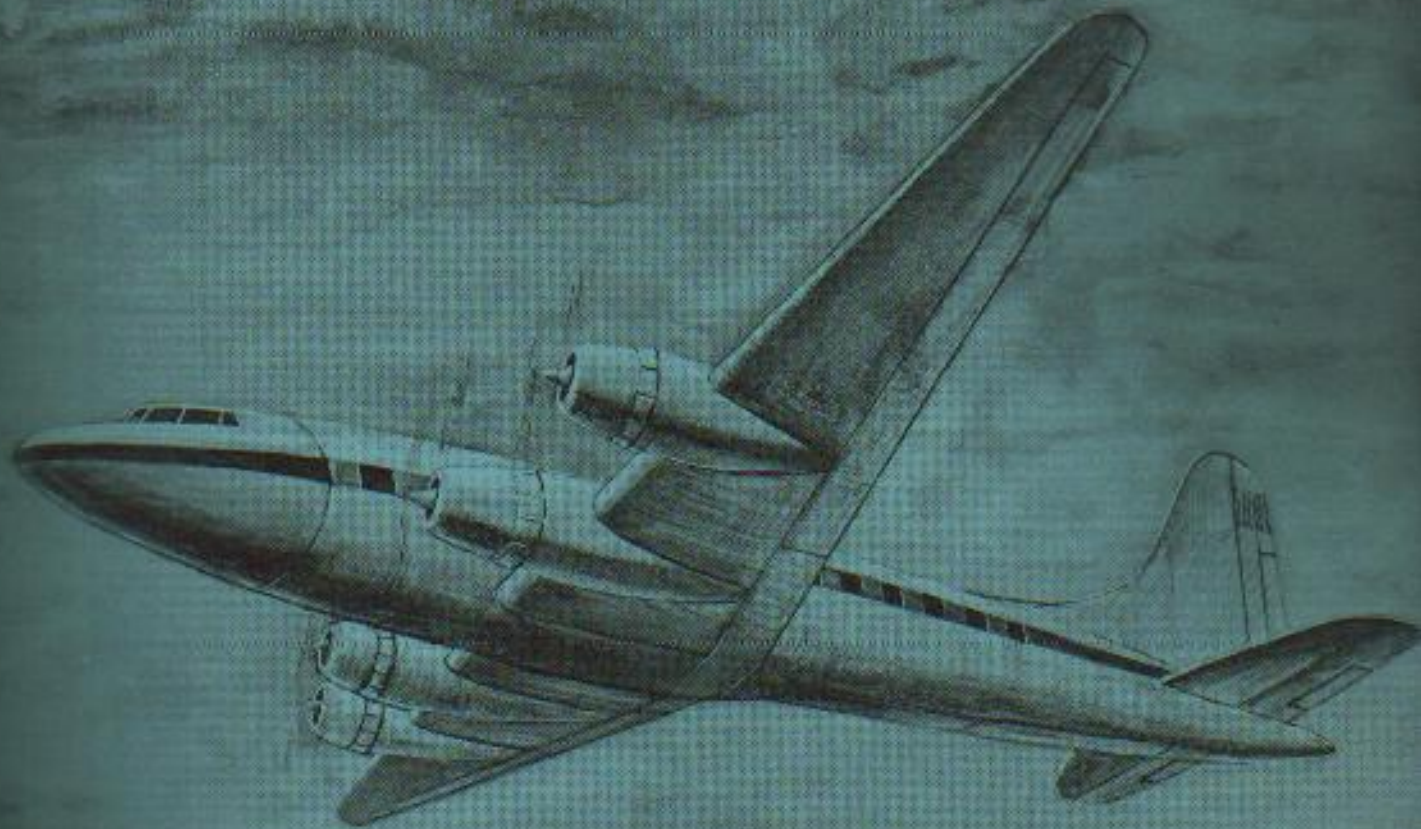

FLIGHT OPERATION

FLIGHT OPERATION

TAKE-OFF

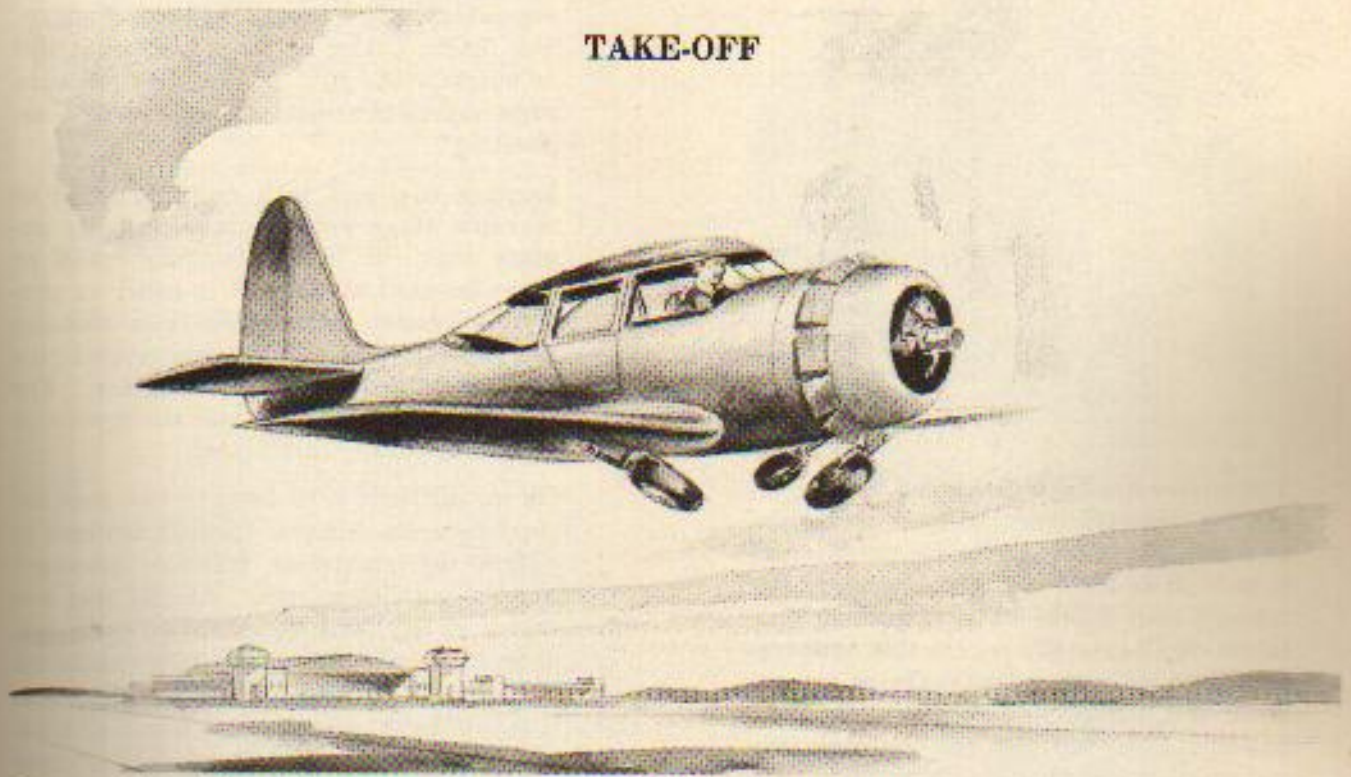

General Considerations

At the start of the take-off run the engine, for the first time since starting, is encountering conditions resulting from the use of high

power. The considerations governing the proper balancing of all operating factors must now apply.

1. **Power.** The Take-off rating is provided to be used, and there should be no hesitation in taking advantage of the full rating. To qualify a type of engine for Take-off rating, the type test engine must be operated continuously for 10 hours at this output, or the equivalent of over 1000 take-offs. There need be no thought that the engine is close to the brink of destruction when this power is applied. The use of the full rating results in the fewest "rpm-power" minutes and the least "piston miles" before reaching the power reduction point. As high rpm is the factor producing the greatest wear the maintenance of maximum rpm for the shortest possible time is the most favorable treatment of the engine.

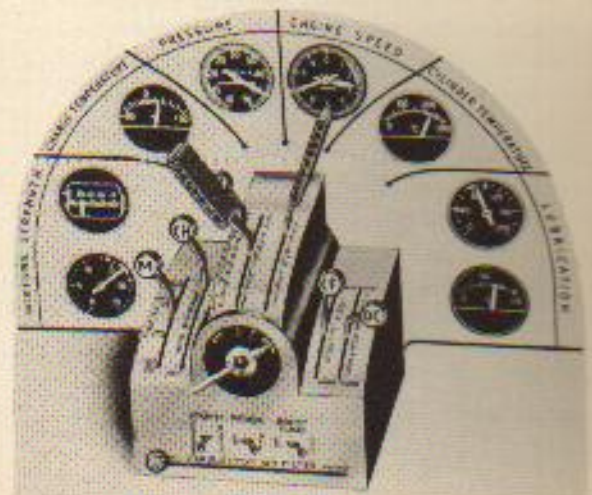

2. Speed — Rpm

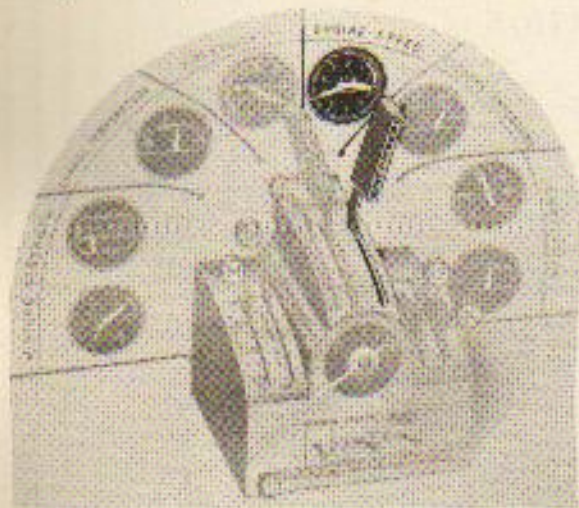

The engine has been developed to be operated at take-off rpm without detonation even though the carburetor air temperature is as high as 100 F (40 C). Therefore full take-off rpm should be used without hesitation on all take-offs within this temperature limit. If higher temperatures are encountered a reduction from full take-off power may be required but the necessary reduction of output is usually accomplished with the throttle. It is possible that under extreme temperature conditions (greater than 120 F or 50 C), an rpm reduction may be the best means of reducing the charge temperature to a safe value as the slower impeller speed prevents excessive heating in the supercharger.

3. Pressure — Manifold Pressure

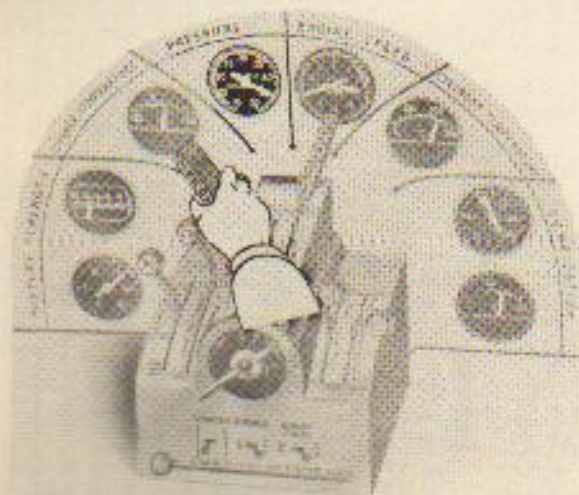

The pressure is applied by advancing the throttle smoothly to the desired manifold pressure. In a few installations automatic regulators will prevent exceeding allowable limits, but on all other aircraft it will be necessary to give the manifold pressure gage sufficient attention to prevent "overboosting".

Engines equipped with multiple speed or multiple stage superchargers usually require that the lowest impeller speed or stage be used at take-off in order to prevent excessive temperature rise through the supercharger. Exceptions to this rule may be allowed on specific engines. For complete information consult the applicable specific operating instruction.

On installations with fixed or two-position propellers, the limit of throttle advance is defined by maximum manifold pressure and/or maximum rpm. At the one extreme of low altitude combined with low free air temperature, limiting manifold pressure may be reached at less than limiting rpm. At the other extreme of high altitude and/or temperature, take-off rpm may be obtained at less than take-off manifold pressure. It is essential that both instruments receive the necessary attention at this time.

4. Mixture — Fuel-Air Ratio

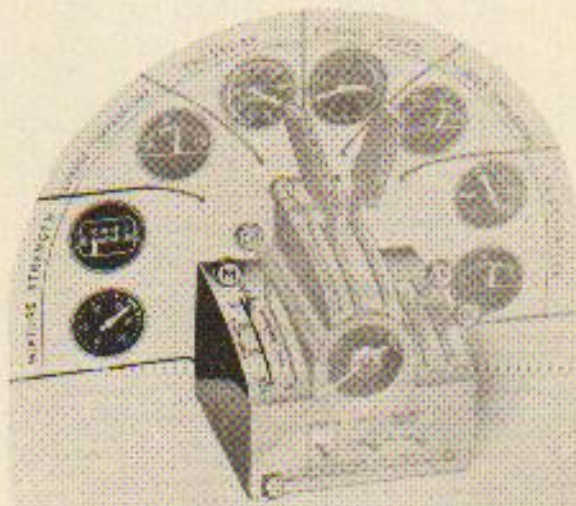

The combination of: high impeller speed with its attendant charge temperature rise; high manifold pressure, and; rising cylinder

head temperature caused by lack of cooling airflow requires that the mixture be considerably enriched during the take-off. To provide this mixture use automatic rich in the case of automatic carburetors or rich in the case of manually controlled carburetors. As a result of the previous checks of engine operation and fuel pressure the pilot will have the assurance that the required fuel-air ratio will be obtained.

5. Charge Temperature — Carburetor Air Temperature

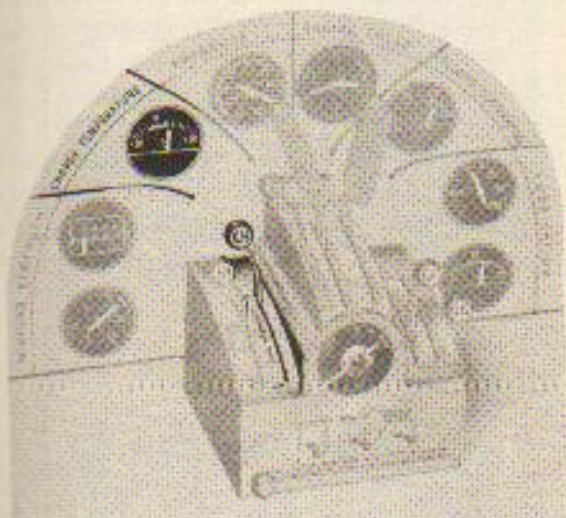

Conditions may arise when it is necessary to use carburetor heat to eliminate ice before, and even during, the take-off. When ice has formed during ground operation a short run to 90% rated rpm with the carburetor temperature control in "Full Hot" will suffice to clear out the induction system. The control then should be returned to "Cold" before beginning the take-off.

In the remotely possible event that heat is needed during take-off, sufficient attention must be given to the temperature indicator and the control to prevent the carburetor air temperature exceeding the recommended limits set for any specific engine model.

Obviously, when the free air temperature is near or above the recommended limit it is not possible to maintain this limit.

6. Cylinder Temperature

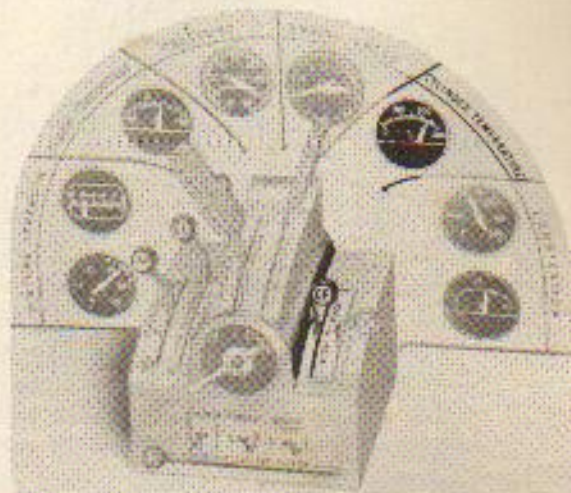

a. Maximum Temperature



The high pressure loads of take-off power require that the cylinder head strength not be reduced as the result of excessive temperatures. It can be anticipated that the head temperatures will increase 45-55 F (25-30 C) during the run as the average cooling airflow is insufficient to cool the engine at this output on a continuous basis. Therefore, before the run is started the head temperatures must be sufficiently low to prevent this rise from exceeding limits. Even in the coldest weather a cowl flap opening greater than the closed position is essential. The ignition harness especially needs more cooling airflow than closed flaps will provide during the take-off.

b. Minimum Temperatures

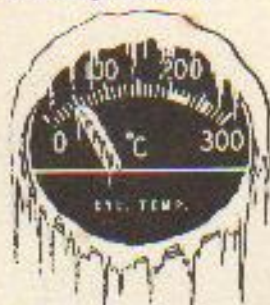

There is no fixed minimum cylinder head temperature. Satisfactory engine operation has been obtained with head temperature as low as 75 F (25 C); and it is not known if this is the low limit. Warmer temperatures are recommended as they usually assist in fuel vaporization and distribution and, hence, smoother running. 250 F (120 C) has been suggested as a minimum based on general considerations of over-all engine conditions. It should not be construed from any such instruction that it is necessary to employ unusual means to bring the heads up to any specific limiting minimum temperature. The oil temperature is the best gage of the over-all engine conditions.

7. Lubrication — Oil Temperatures

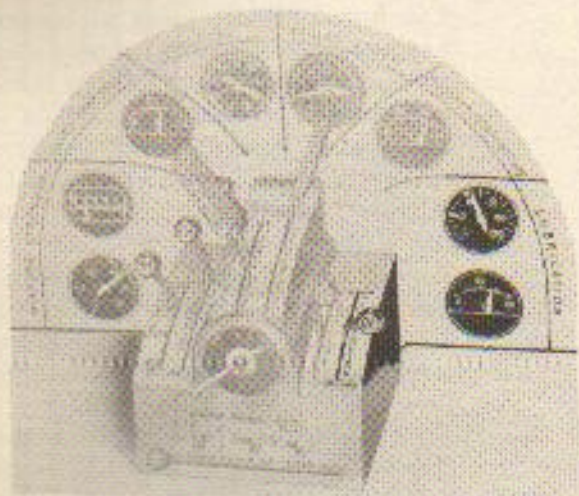

100 F (40 C) is the absolute minimum of the oil inlet temperature range which will ensure proper lubrication and flow of oil

to critical bearings for cooling purposes. No take-off should be made until the oil has warmed up at least to this point and 140 F (60 C) is preferable. The maximum temperature prior to take-off should allow for the rise which inevitably follows, similar to the rise in head temperatures. This increase will vary with different installations, depending on the capacity of each system, whether or not all the oil contained in the system is used continuously, and the type of temperature regulation. The maximum limit must not be exceeded as high temperatures can result in foaming and discharge through the breathers, as well as the natural reduction in lubricating qualities. This is especially true while operating under conditions of take-off power and temperature.

As take-off power and speed are the conditions of the greatest need for lubrication, the functioning of the lubrication system, as evidenced by oil temperature and pressure during the pre-take-off run-up, should be carefully checked.

8. Ignition

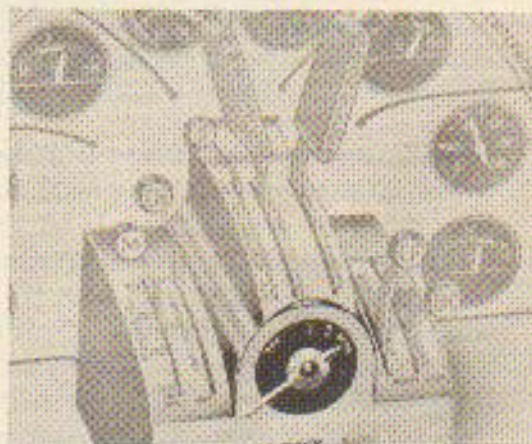

No take-off should be performed without assurance of proper ignition system functioning. While less than perfect ignition operation can be tolerated under conditions of low engine power and speed, the high pressures and high intake temperatures encountered during take-off require that the entire system be functioning in order that the engine may maintain maximum output without detonation. The magneto check at approximately 65% power has been found to satisfy this requirement.

PREPARATION FOR TAKE-OFF — CHECK-OFF LIST



A properly prepared and consistently followed check-off list will ensure that all necessary steps are taken while preparing for take-off. The take-off run with its demands for complete attention is no place to be worrying about the proper position of a control or the functioning of an auxiliary system. The completion of the check will give the pilot a clear conscience concerning items which otherwise might be neglected.

The following is a suggested power plant check-off list:

- | | |
|---------------------------------------|--|
| 1. Cowl Flaps | — Full open |
| 2. Rpm | — Set for take-off |
| 3. Fuel Selector | — On suitable tank* |
| 4. Mixture | — Rich |
| 5. Carburetor Air Heat | — Cold (except as discussed) |
| 6. Carburetor Air Filter | — As required |
| 7. Supercharger
(where applicable) | — Low, Neutral, or Off |
| 8. Check Magnetos | — Same as 30 in. Hg ground check** |
| 9. Observe | — Oil Temperature
Oil Pressure
Fuel Pressure
Cylinder Temperature |
| 10. Oil Cooler Shutters | — Adjusted for take-off |
| 11. Cowl Flaps | — Adjusted for take-off |

NOTE: A check-off list for a specific aircraft would include items outside of the power plant inserted to give the proper sequence.

*This is encroaching on the aircraft manufacturers' preserve, but the number of engine failures resulting from improper fuel selector position warrants its mention here.

**If the plugs show signs of becoming fouled, a short run at 30 in. Hg should clear them out.

TRANSITION FROM TAKE-OFF TO CLIMB

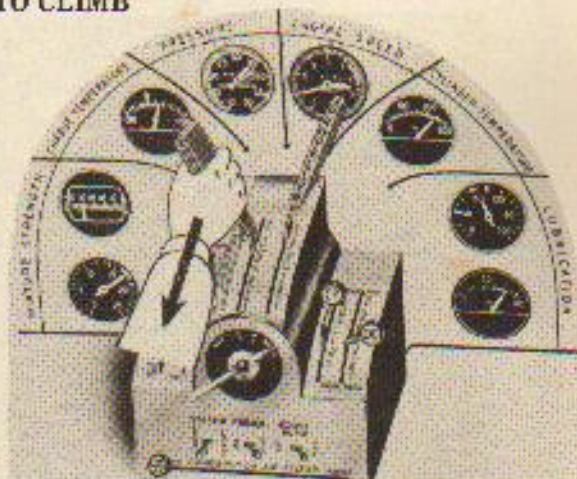

As soon as the field and surrounding obstacles are cleared, reduce power at least to Normal Rated. With constant speed (variable pitch) propellers the reduction should be accomplished in steps as follows:

1. Retard throttle to reduce manifold pressure to about 2 in. Hg below that for Normal Rated power (with fixed part throttle, manifold pressure will rise as rpm is reduced).
2. Retard the rpm control to Normal Rated rpm.

If a further reduction in power is desired, proceed as follows:

1. Lower manifold pressure by 2 in. Hg.
2. Lower engine speed by 200 rpm.

Continue in successive alternate steps until the desired engine speed is reached, finally adjusting the throttle to the desired manifold pressure.



This is not to be construed to mean that the throttle should never be advanced with a low rpm. The engine is not affected by the position of the throttle—it is affected by the manifold pressure resulting from the throttle position.

FLIGHT — GENERAL

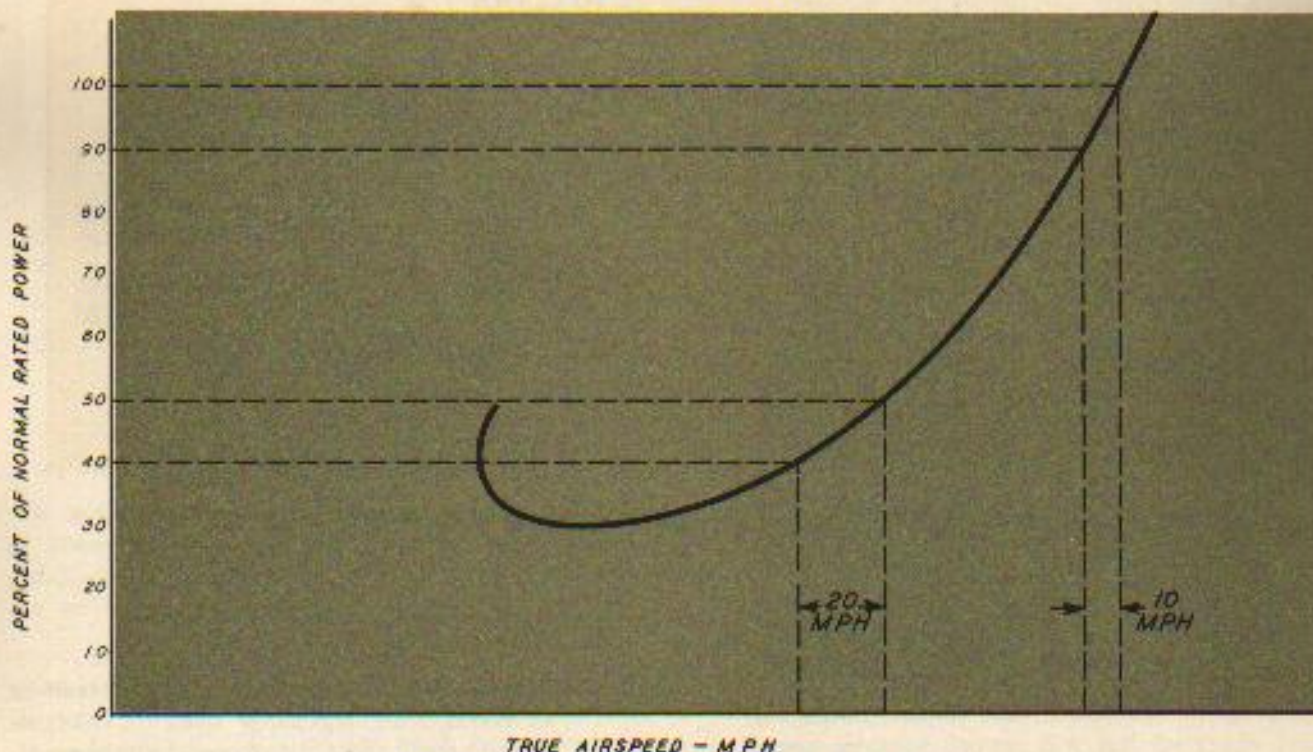

Fig. 29 — Brake Horsepower vs True Airspeed

POWER

Other than specifying maximum limits of power, the engine manufacturer cannot prescribe definite outputs to be used for the various conditions of flight. There are no direct answers to the questions: "What is cruise (power)?" and "What is climb (power)?" The pilot has available any power from the minimum necessary to sustain the aircraft up to Normal Rated. What he should use is governed by what quality of service he wishes to emphasize: performance, or economy and durability.

1. Aircraft Performance vs. Power

The relation between aircraft speed and engine brake horsepower is illustrated by Fig. 29.

The significant information to be obtained from this curve is the low return in increased airspeed for a given increase in power at high output as compared to medium outputs. The upper portion of the curve follows closely the relationship given by the equation:

$$\frac{Bhp_1}{Bhp_2} = \left(\frac{V_1}{V_2} \right)^5$$

where V_1, V_2 = two different airspeeds
and Bhp_1, Bhp_2 = the brake horsepowers necessary to obtain the corresponding speeds.

The equation, it will be noted, is similar to the propeller load formula, and in non-mathematical language simply means that 8 times the power is required to double the air speed, and 27 times the power to triple it. Stated another way: if the bhp is increased in increments of 10% Normal Rated power, an airplane which develops an airspeed of 220 mph at 40% of power will realize a gain of 20 mph as the bhp is advanced to 50% of power; but will increase its speed by only 10 mph (i.e., from 289 to 299 mph) as the bhp is increased from 90% to 100% of Normal Rated power.

2. Performance vs. Fuel Consumption

Perhaps of even greater interest is an illustration of the relationship between airspeed and miles per gallon.

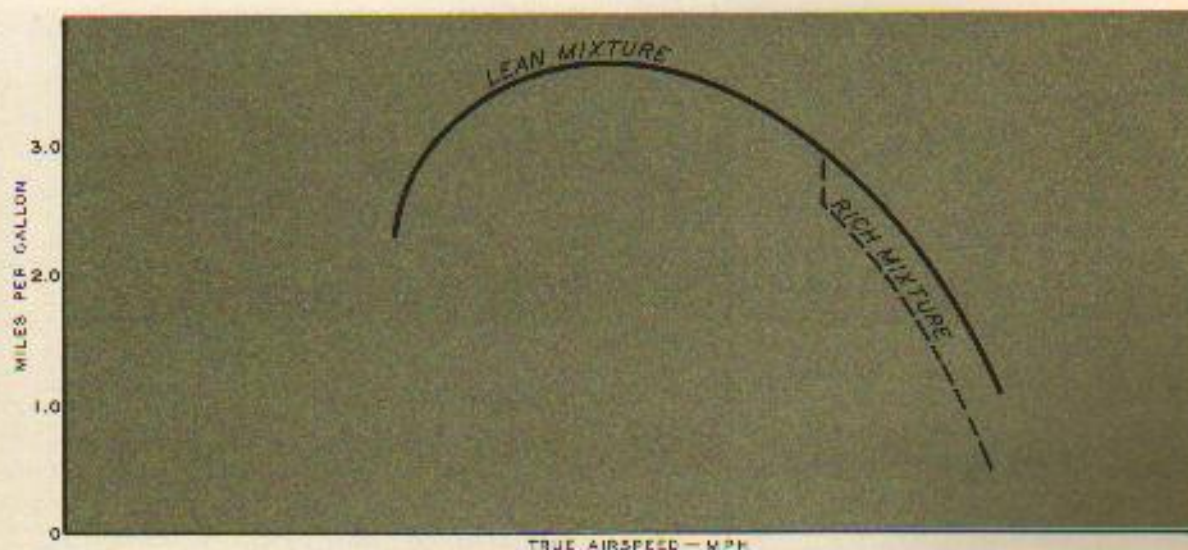

Fig. 30 — Miles Per Gallon vs True Airspeed

It should be obvious from this curve that economy of fuel cannot be realized by operating at a high percentage of power. The decrease in miles per gallon as speed is increased is the result of the rapid increase in power required, combined with the fuel enrichment accompanying high power operation.

3 Performance vs. Durability

The durability of the engine as measured in the number of hours between overhauls is also a factor which varies with the amount of power used, and so can be shown as varying with airspeed.

This is another way of stating that an engine can be used for a certain number of power-hours before requiring an overhaul. These power-hours can be used up in a short time by high power operation or they can be stretched by reducing the percentage of rated output used continuously.

4. Power Selection

The complete picture of the effect on economy and durability of varying airplane performance can be shown by combining Figs. 29, 30 and 31.

The operator has the entire range of performance to select from and in many cases

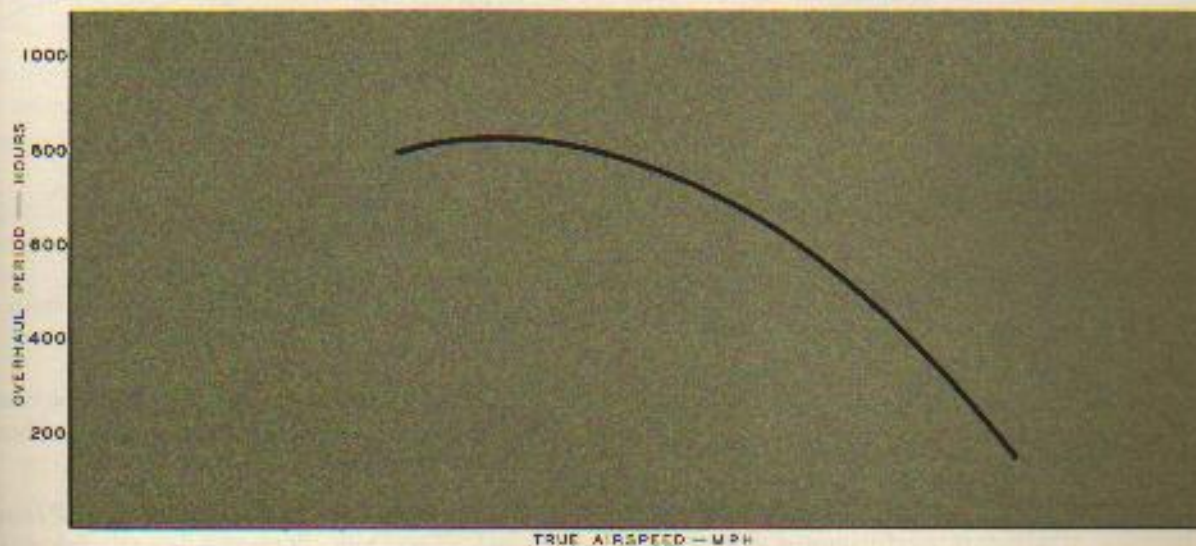

Fig. 31 — Durability vs True Airspeed

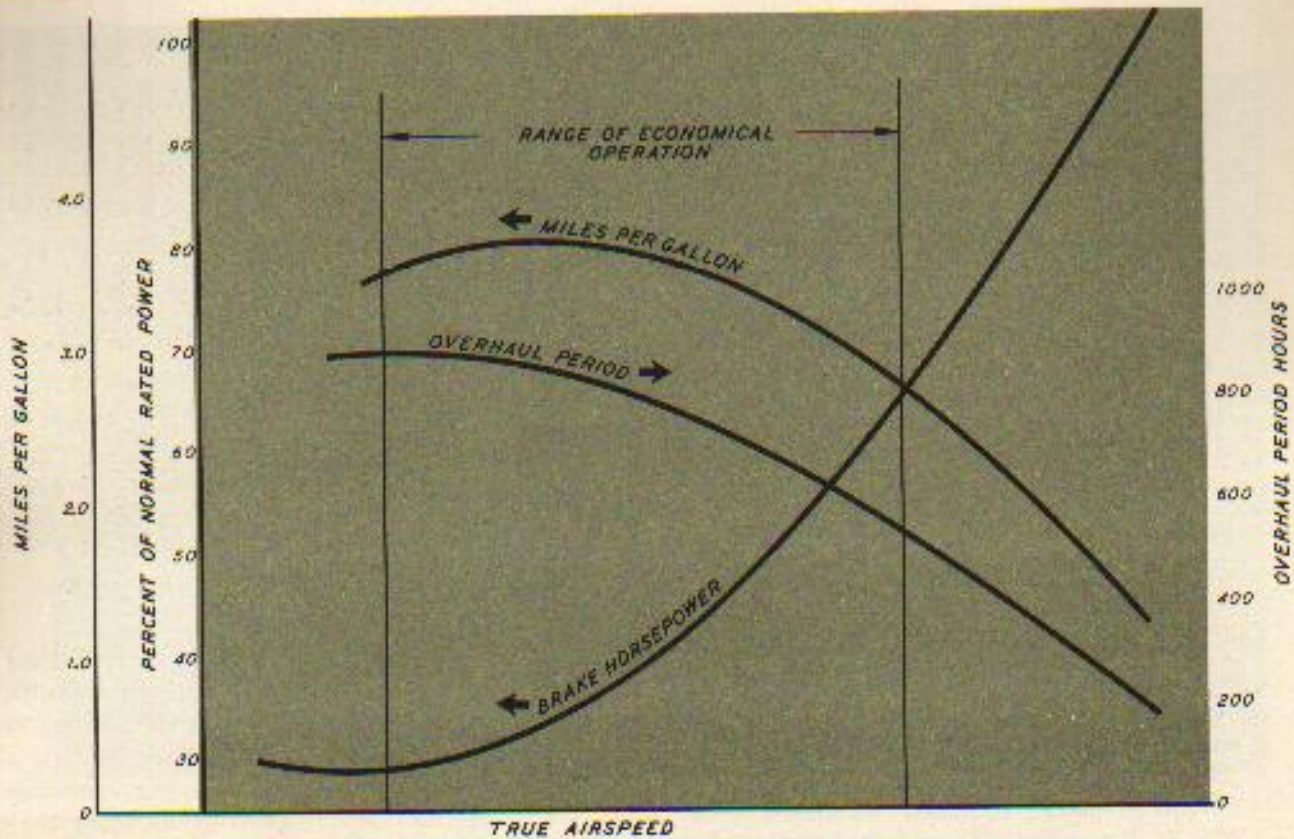

Fig. 32 — Brake Horsepower, Fuel Economy and Durability vs True Airspeed

factors other than fuel economy and engine durability may make it advantageous to use even 100% power continuously. Military aircraft are operated in a manner dictated primarily by tactical necessity; durability and economy are secondary considerations. An airline may, after a thorough analysis, conclude that it is more profitable to fly more trips per day at high speed, thus earning more revenue, even though engine operation costs per mile are increased.

When such considerations are not present it is suggested that power be governed as follows:

1. Climb—80% of Normal Rated power.
2. Cruise—lowest power satisfying performance needs, not to exceed 67% of Normal Rated power.

The accumulated experience of several years has indicated that operation within these limits will result in the optimum balance of aircraft performance and overall economy of operation.

BMEP — CONTROL

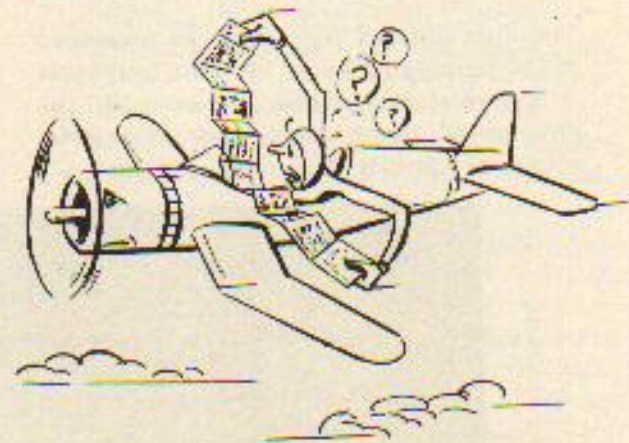

Proper Preflight Preparation Prevents Perplexed Pilots

Having selected the power to be used, the operator still must choose the engine speed for this output.

1. **Fixed Pitch or Two-Position Propellers**
If a fixed pitch propeller is installed, only one combination of manifold pressure and

rpm will give the required power at a given altitude and airspeed. This is also true of either the high or low pitch position of a two-position propeller.

With a two-position propeller the requirements of proper rpm and manifold pressure balance will be best met by operating in the high rpm position during take-off and climb and in the low rpm position during the cruising portion of the flight. Otherwise there is no opportunity to exercise bmep control and establish the optimum combination of manifold pressure and rpm.

2. Variable Pitch (Constant Speed) Propellers

With variable pitch (constant speed) propellers an infinite number of rpm and manifold pressure combinations may be selected to deliver a given power, bearing in mind that, **at constant power, as rpm is increased, manifold pressure must be correspondingly decreased, and vice versa.** For example: engine "A" at sea level will develop 650 bhp at 2600 rpm and 28.75 in. Hg manifold pressure, at 1450 rpm and 37.0 in. Hg, or at an infinite number of intermediate combinations.

In selecting a particular combination of rpm and manifold pressure to obtain a desired power, the operator must regulate the balance between the loads and stresses due to engine speed, on the one hand, and those attributable to cylinder pressure on the other. BmeP accordingly becomes one of the principal factors, not only in the selection of rpm and manifold pressure, but also in determining economy of operation and engine durability.

3. Engine Speed vs. Cylinder Pressure at Constant Power

In the case of an engine operating at constant power, but at different rpm and inversely varying manifold pressures, the effects of speed (rpm) and cylinder pressure (bmeP) on various characteristics of its performance may be summarized as follows:

a. **Friction:** — Reduced by a decrease in rpm. The decrease of sliding and rolling friction more than offsets the corre-

sponding increase in pressure friction.

- b. **Reciprocating and Centrifugal Loads:** — Reduced by a decrease in rpm. Pressure opposes and cushions these loads which predominate in determining the stresses on master rod bearings.
- c. **Detonation:** — Reduced by a decrease in rpm. Inasmuch as the tendency of a fuel to detonate is determined principally by its temperature sensitivity, a low impeller rpm with the attendant low temperature rise through the supercharger is favored. The heat rise varies chiefly with impeller speed and is relatively unaffected by power.
- d. **Fuel Consumption:** — Reduced by a decrease in rpm. As explained above, an increase in rpm is accompanied by

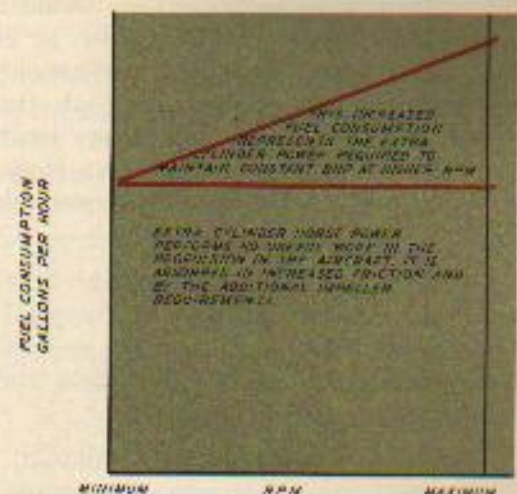

Fig. 33 — Fuel Consumption vs Rpm at Constant Bhp

a constant brake horsepower is to be delivered to the propeller shaft, it follows that the cylinders must develop more power (ihp), and this additional cylinder power requires extra fuel.

- e. **Cylinder Cooling:** — Improved by a decrease in rpm. The reduced cylinder horsepower (ihp) resulting from low rpm operation will be reflected in lower cylinder head temperatures.

- f. **Oil Cooling:** — Improved by a decrease in rpm. Low engine speed is the most effective way to control the tendency of the oil to overheat, since a low rpm reduces the power necessary to overcome friction and, hence, the amount of heat to be carried away by the oil.
- g. **Altitude Performance:** — Above the critical altitude for a given combination of manifold pressure and rpm, manifold pressure decreases, and with it, the engine's power output. Under these circumstances the desired power can be maintained only by increasing engine speed, thereby raising the pumping capacity of the cylinders and increasing the pressure rise through the supercharger.
- h. **Vibration:** — It has been the practice to select engine and rpm combinations which appear to give acceptable cockpit and cabin comfort. Engine suspension systems of earlier types tended to favor a bmep lower than would be selected from considerations of engine efficiency. Present developments of engine suspensions are such that, in general, there is little if any limitation to the use of the full rpm range and speeds as low as 1200 rpm may be entirely practical.

It may be concluded from the foregoing discussion that it is generally preferable to operate the engine on the side of high manifold and cylinder pressures and low rpm.

Cylinder pressure must be limited, how-

ever, because of structural and experience considerations. These limits can be described in terms of bmep, and may be illustrated as follows:

4. **Maximum Cylinder Pressure Limit**

A line joining 0% power and rpm with 100% normal rated power and rpm defines the minimum recommended engine speed for normal rich mixture operation. Higher bmep should not be used unless there is a reason proved by analysis for so doing.

For all models of engines produced by Pratt & Whitney Aircraft specific operating instructions give recommendations for the maximum bmep to use when operating with lean mixture. These limits are established by extensive engine testing and their observance will result in the greatest benefits of engine durability for the average operator. The following are the recommended lean mixture bmep limits for certain Pratt & Whitney Aircraft engine models now in current use. For information regarding other models see the applicable specific operating instructions.

Model	Recommended Maximum Lean Mixture bmep
Wasp, Jr.	120
Wasp	120
Hornet	125
Twin Wasp (C series)	140

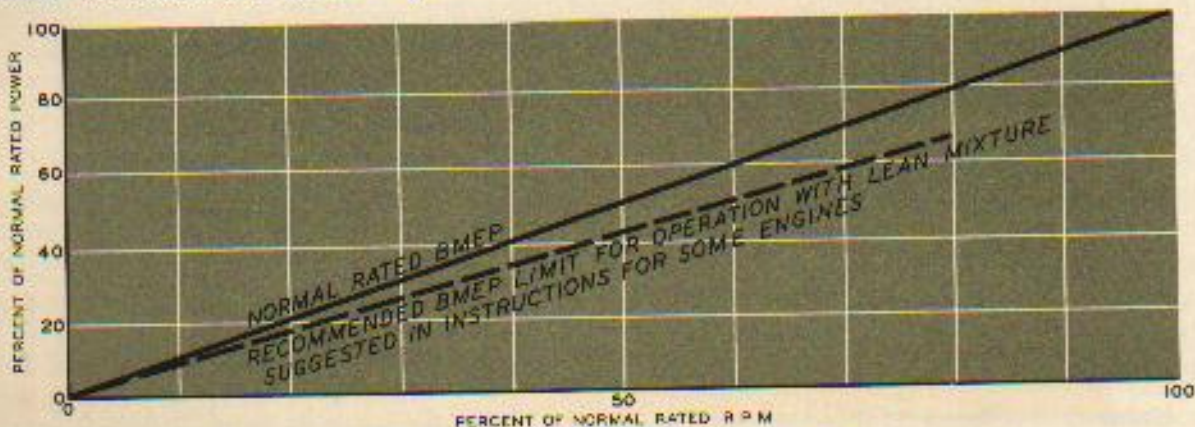

Fig. 34 — Brake Horsepower vs Rpm — (Bmep)

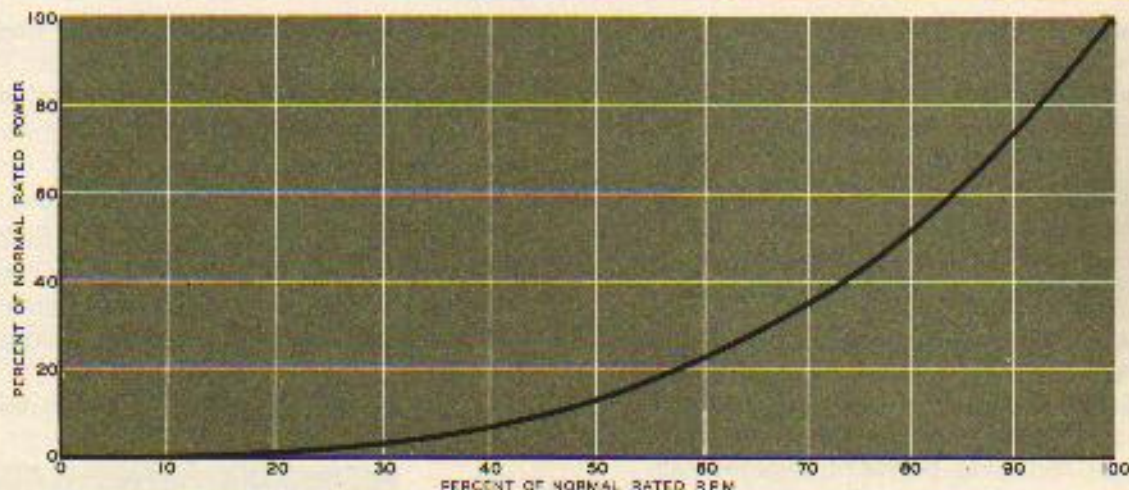

Fig. 35 - Brake Horsepower vs Rpm - (Propeller Load)

5. Maximum Rpm Limit

The high rpm limit of operation can be conveniently defined by a propeller load curve passing through Normal Rated power and rpm.

Operation at engine speeds lower than propeller load will ensure that the loads set up by high rpm are never excessive and will be sufficiently cushioned by pressure.

6. Desired Rpm Range

Combining the pressure and rpm limits, the area of best operation would appear as shown in Fig. 36.

It will be noticed that a considerable range of power and rpm combinations is still available at medium percentages of the normal rating. Exact definition of the optimum combinations for operating in this area must come from the aircraft

manufacturer. On practically all counts the engine will wish to run at the maximum bmep. The propeller prefers an engine speed more nearly at propeller load. The airplane by itself will wish to be flown somewhere in between depending upon its own characteristics. The answer can only be obtained by combining the three units together.

If maximum miles per gallon are desired, the engine will say, "Operate me at the lowest brake specific fuel consumption." This may result in a propeller speed so low that the blade angle will increase to the point where it is "paddling" the air and providing little thrust. The engine will feel very satisfied as it will be using the least gallons per hour, but the airplane will not go very far with a given amount of fuel because of the inefficiency of the propeller.

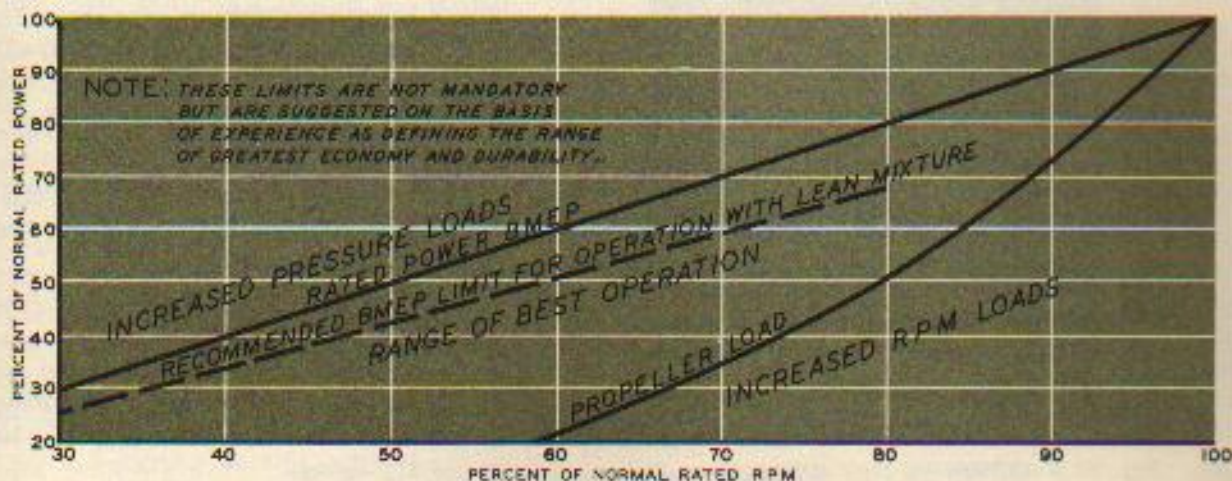

Fig. 36 - Range of Rpm and Power as Defined by Propeller Load and Suggested Maximum BmeP

The propeller will say, "Operate me at the rpm where I can give the greatest efficiency." This may be at an engine speed resulting in high fuel consumption as too much cylinder power is wasted in overcoming friction and driving the impeller. The airplane will achieve the highest airspeed for the brake horsepower delivered but at the expense of high fuel consumption.

The airplane without thinking of the engine and propeller will say, "Fly me at the speed giving the best ratio of lift to drag." This may leave both the engine and propeller at inefficient points of their operating range and economy will again suffer. In general, maximum over-all efficiency favors staying close to the high limit of bmep above 50% power but reducing bmep below this limit depending on the airplane, altitude of operation, propeller, and reduction gear ratio. The final answer is obtained by simple straightforward flight tests covering the necessary conditions.

The requirements of proper engine operation will be satisfied if the power and rpm lie within the limits shown.

7. Altitude of Operation

As supercharging the engine involves increased weight and complexity, operations should be conducted at altitudes where the capacity of the supercharger is fully utilized, in other words, at approximately the

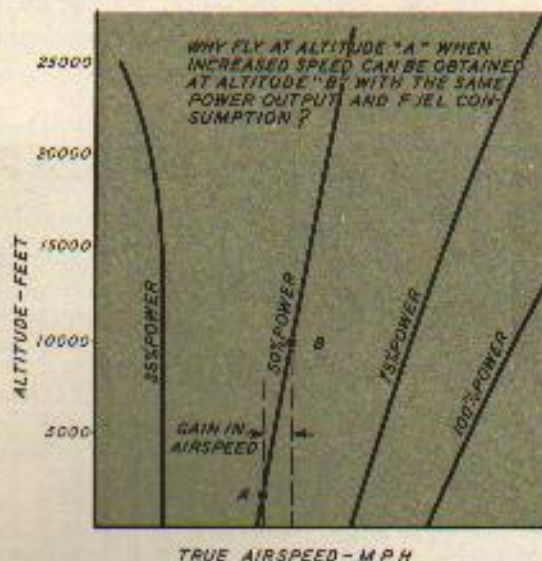

Fig. 37 - Altitude vs True Airspeed

full throttle, or critical, altitude where air-flow restriction is at a minimum. The relation between altitude and airplane true airspeed at constant power is shown in Fig. 37.

Obviously, if the supercharger has the capacity to allow the engine to develop power at a high altitude, operating at this altitude will result in higher speed and, as fuel consumption varies with power, more miles per gallon. The power curves can be put to good use in flight planning.

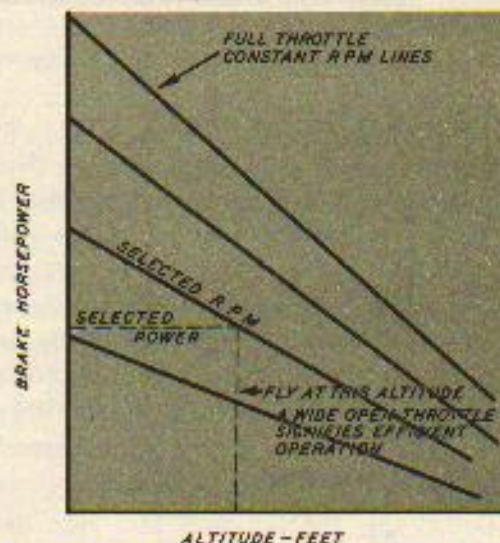

Fig. 38 - Brake Horsepower vs Altitude

By finding the critical altitude of the power and rpm combination to be used, the optimum altitude for operating under these conditions is determined. The following three exceptions to this rule must be taken into account:

- a. Length of flight: — On short flights it may not pay, either in over-all miles per hour or in over-all fuel consumption, to spend the time and fuel climbing to the critical altitude.
- b. Wind variations: — Head or tail winds may favor a deviation from the optimum no-wind altitude.
- c. Maximum range operation: — When the maximum possible range must be realized more comprehensive information must be obtained. The above considerations apply to simple cross-country flying.

8. Induction System Icing

Ice formation within the induction system is often a potential hazard of engine operation. It is difficult to approximate the frequency of this condition. The more advanced cases of icing, which cause serious malfunctioning of the engine, are comparatively few in number, but they cause a great deal of concern, and should be absolutely eliminated.

Ice may be formed in the induction system by three different processes which are classified as follows:

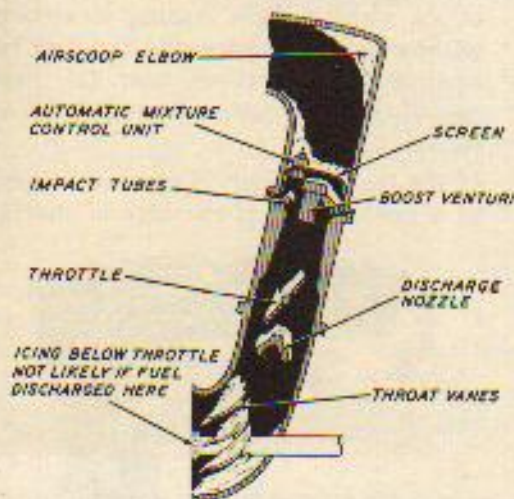

- a. **Impact Ice**—which is that formed from water that originally existed in the atmosphere as snow, sleet or sub-cooled liquid, and includes that formed from liquid water impinging on surfaces that are at temperatures below 32F (0C). The most dangerous impact ice is that which may collect in and on the metering elements of the carburetor, affecting the fuel-air ratio. Other critical points are the preheater valve and walls of the scoop near it, the roof of the scoop elbow and screens.
- b. **Throttle Ice**— which is formed at or near the throttle when it is in a part-closed position, due to the cooling effect caused by the restricted flow area. This ice may form at carburetor air temperatures as high as 35 F (3 C).
- c. **Fuel Ice**—which is formed because of the cooling effect of the fuel evaporat-

ing after it is introduced into the air stream. This ice probably occurs most frequently in actual operation because it may form at carburetor air temperatures considerably above 32 F (0 C). Most of the heat necessary to evaporate the fuel is taken from the air, which causes it to drop in temperature. Fuel ice may affect airflow by blocking off the supercharger entrance (blower throat), affect fuel-air ratio by interfering with the fuel flow, and affect mixture distribution or quantity of mixture to individual cylinders by upsetting the fuel flow at the fuel nozzle distributor, or air flow distribution at the supercharger entrance. Under certain conditions of high humidity, this ice may form with carburetor air temperatures as high as 80 F (25 C). Tendency for fuel ice to form is greater with float type carburetors and to a lesser extent with pressure injection carburetors having the X-bar fuel distributor. The newer type spinner fuel distributor developed by Pratt & Whitney Aircraft for the pressure injection carburetor has practically eliminated icing of this type.

Indication of icing conditions in the induction system in the order of probable perception to the operator are as follows:

- a. **Decrease in manifold pressure**—due to restriction of induction passages, with consequent loss of power.
- b. **Changes in fuel-air ratio**; the mixture becoming either leaner or richer. This may cause serious loss of power without any change in manifold pressure.
- c. **Sticking of the throttle valve.**
- d. **Icing indicator instruments** — (if installed).
- e. **Surface icing** — of the wings or other surfaces.

The means and procedures for ice prevention depend upon the manner in which the fuel is discharged into the induction system.

- a. **Fuel injected immediately downstream from the carburetor** (includes all Pratt and Whitney Aircraft engines with float carburetors and the Twin Wasp C series). When the fuel is injected immediately downstream from the carburetor a considerable volume is avail-

able in which fuel evaporation ice can form. Turning vanes offer a convenient surface for the ice to cling to and complete blocking of the passage can quickly occur. With this type of equipment, effective prevention of ice formation is obtained by maintaining the temperature of the air entering the carburetor sufficiently high so that the temperature drop due to evaporation will not reduce the temperature in this critical region below freezing, 100 F (40 C) carburetor air temperature should be used when possible ice formation conditions are present. As the prevention of evaporation ice requires the maximum degree of heat the other icing possibilities are taken care of adequately. Do not apply greater pre-heat continuously as each increase in carburetor air temperature represents possible loss of engine performance and excessive carburetor heat can lead to detonation.

When flying in sub-freezing temperatures the operator must guard against using insufficient preheat. It is possible, when using "cold" air, for the contained moisture to pass through the engine without changing its form. However, if the carburetor entrance temperature is elevated to 32-80 F (0-25C) this moisture will be changed first from a frozen to a liquid condition and, when fuel evaporation takes place, will return to the frozen state in the induction passages. Under such conditions either use 100 F (40 C) preheat or leave the air temperature control alone.

- b. **Fuel injected at or downstream from the face of the impeller.** (Includes engines with spinner injection.) With this equipment fuel evaporation ice is no longer a critical factor. Generally 60°F (15 C) preheat will be adequate to prevent ice formation. While a large preheat capacity is not needed to prevent ice formation, the instant availability of a temperature increase of 100 F (56 C) or more will ensure the ability to remove ice already formed. Some engines in this category require definite restric-

tions in the use of preheat in order to prevent detonation. This is especially true when using the high impeller ratio of a single-stage, two-speed engine. For more definite information regarding individual engines refer to the applicable specific operating instruction.

Removal of ice causing loss of manifold pressure is best accomplished by use of full carburetor heat. If the preheat capacity is sufficient and the remedial action has not been delayed, it is a matter of seconds until the ice is removed. The preheat capacity can be increased by applying more power and by closing the cowl flaps. However, removal of ice which causes leaning or enrichment without manifold pressure loss may require application of limited heat for extended periods of time before the condition is corrected.

If the ice formation is allowed to progress to a critical extent the loss of power may

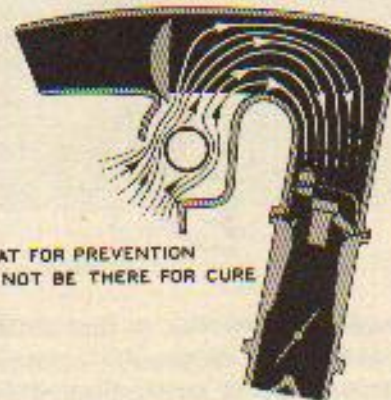

USE HEAT FOR PREVENTION
IT MAY NOT BE THERE FOR CURE

make it impossible to generate sufficient heat to clear the engine. Because of this possibility it is imperative that the crew be alert to possible icing conditions and take remedial action while it can still be effective.

Operation of the engine at high bmep (large throttle opening and low rpm) may assist in minimizing the possibility of ice by reducing this obstruction across the airflow. Also, a change of altitude may result in finding ice-free conditions.

There is record of some operators clearing ice by causing the engine to backfire. This rigorous procedure should be resorted to only in extreme emergency and it is important to ensure that the carburetor heat control is in the "cold" position and the filter is "off" so as to prevent damage to these items.

CLIMB

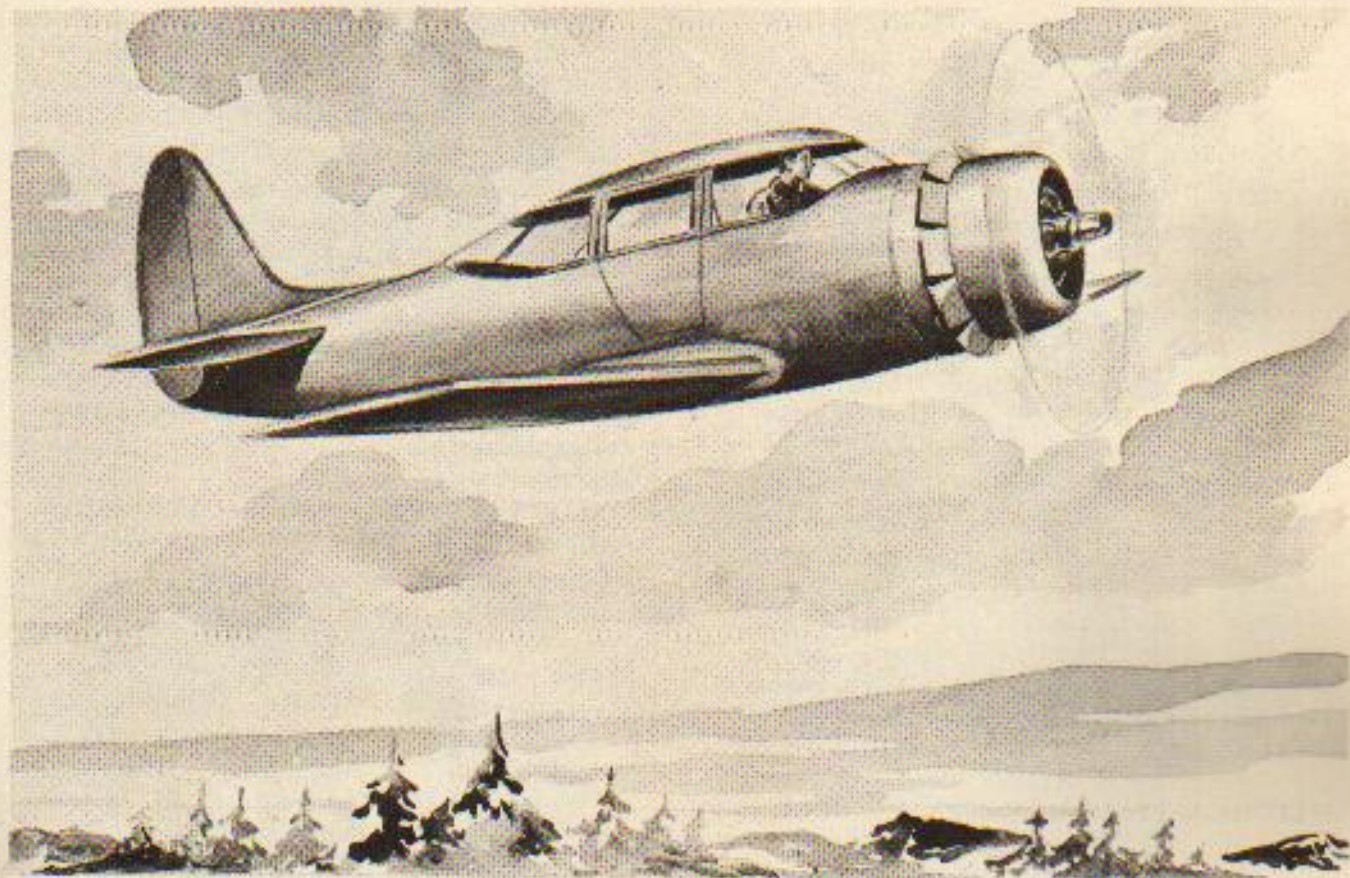

Basically climb differs from level flight only in lowered airspeed. An airplane towing a glider in level flight is subjecting its engines to the same conditions as in an unencumbered

climb at the same indicated airspeed. The higher powers used for climb combined with reduced cooling airflow call for closer attention to cylinder and oil cooling.

POWER**Maximum**

Military Services — Military Rated (Time Limited)

All Others — Normal Rated
(Special ratings may be available on specific engine models)

Recommended

All Normal Operations — 80% of Normal Rated Power or Less

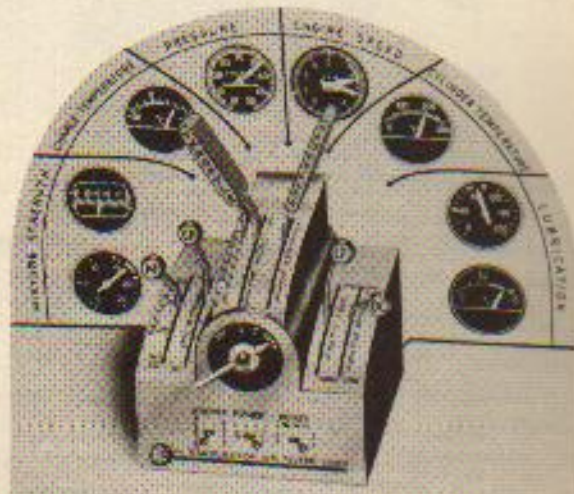

SPEED AND PRESSURE — RPM AND MANIFOLD PRESSURE

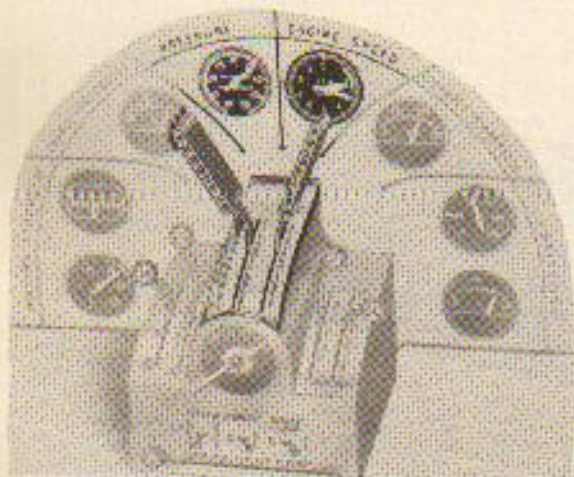

Select rpm to give power within limits shown in Fig. 36. Greater than Normal Rated bmeq should be used only when it is known that definite advantages are obtained. If the climb is continued above the critical altitude for the power and rpm selected, increase the engine speed 50 rpm for each inch reduction of manifold pressure.

MIXTURE — FUEL-AIR RATIO

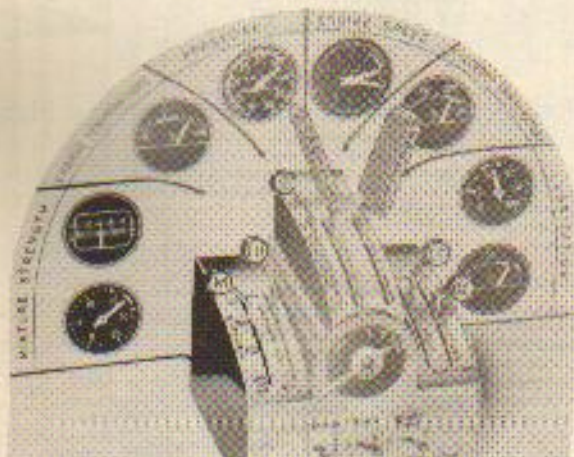

Rich mixture is used in climb to assist the limited airflow in maintaining the desired cylinder temperatures, and to counteract any tendency of the charge to detonate because of the heat rise through the supercharger when the engine is operating at a high percentage of Normal Rated rpm.

1. **Automatic Carburetors:** On current engines provided with automatic carburetors, rich mixture is provided by positioning the control in automatic rich. An indent on the

latch cover of the mixture control can be felt through the cockpit control, and proper positioning positively assured. As new developments take place different nomenclatures may be used to denote proper mixtures. Consult the applicable specific operating instructions.

2. **Non-Automatic Carburetors:** Rich mixture is obtained on non-automatic carburetors in the full forward position of the control. Above 5000 feet it may be necessary to retard the control to compensate for the effect of altitude on the uncompensated carburetor. This retarding should be limited to the amount required to maintain smooth operation.

CHARGE TEMPERATURE — CARBURETOR AIR TEMPERATURE

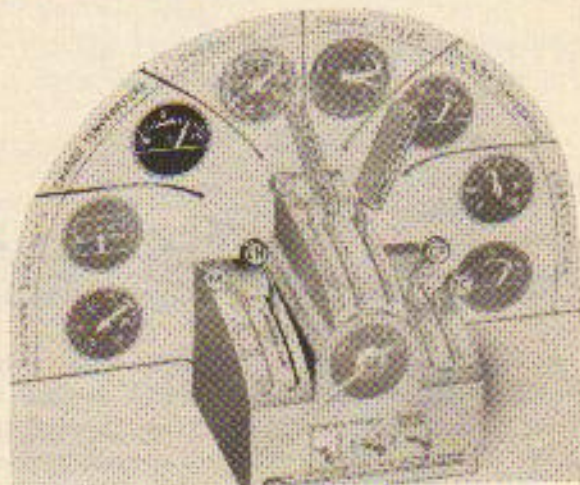

Any necessary use of preheat during the climb must be closely controlled so as not to increase to a critical value the high mixture temperature resulting from high rpm. If detonation is encountered during the climb, the most effective corrective action is to reduce manifold pressure and rpm. The rpm is reduced to lower the impeller speed, thus reducing the supercharger heat rise. The lowering of manifold pressure is necessary in order to stay within bmeq limits.

The carburetor entrance temperature limit for single-stage, single-speed engines at normal rated rpm, or greater, is usually 100 F (40 C). When higher entrance temperatures are required to eliminate ice already formed, reduce manifold pressure and rpm so that the final charge temperature will not be excessive.

CYLINDER HEAD TEMPERATURE

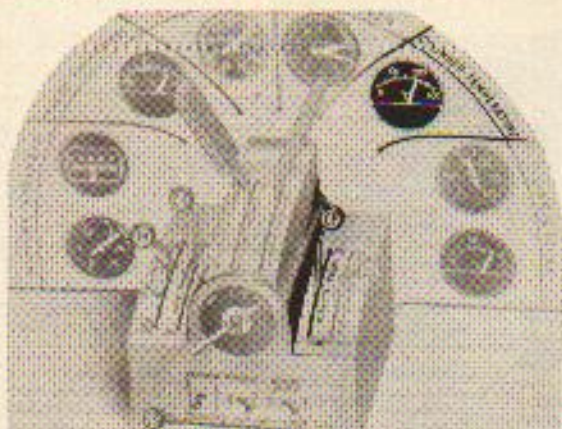

Two limiting cylinder head temperatures are tabulated for the specific operating instructions.

1. Absolute Maximum

This temperature is allowed for a limited period during the conditions of climb and maximum power in level flight. It must be remembered that the high cylinder pressures encountered during these phases of operation impose high stresses on the head material, and the maximum temperatures should not be allowed at this level for a longer period than is necessary. Exceeding this limit seriously weakens the heads.

Ample experience has proved that it is safe to use the absolute limiting head temperature provided the time period specified is not exceeded. The richer mixture used under these conditions assists in maintaining combustion chamber temperatures within proper limits. By allowing this limit during climb and high speed level flight, the aircraft manufacturer can provide the necessary cooling airflow during these temporary conditions without unnecessarily sacrificing continuous performance.

2. Maximum Continuous

This is the maximum cylinder head temperature for continuous operation regardless of power. While maintenance of temperatures at this limit will give safe operation, dependability is increased by holding a lower temperature in order to increase the operating strength of the head material. Where possible, the cylinder temperature should be maintained below 400 F (200 C) during climb and level flight.

Any tendency on the part of the head temperatures to remain high during climb should be counteracted as follows:

1. Cowl Flaps (where provided) — Increase opening to the maximum permitted by the airplane characteristics.
2. Airspeed — Increase airspeed by reducing the rate of climb to increase cooling air pressure at front of engine.
3. Fuel-Air Ratio — Mixture automatic rich or as rich as possible consistent with smooth operation in the case of non-automatic carburetors.
4. Power — Reduce manifold pressure and rpm to reduce the amount of heat generated.

LUBRICATION



Where manual control of oil temperature is provided, the oil cooler control should be set to maintain the desired temperature. When the control, whether manual or automatic, will not give the necessary temperature regulation, take the following steps:

1. Reduce rpm and manifold pressure.

The rpm reduction reduces the amount of heat transmitted to the oil by lowering engine friction. The manifold pressure reduction may be necessary in order not to exceed bmeq limitations.

A reduction of power unaccompanied by a reduction of rpm has little effect on oil temperature.
2. Increase airspeed without increasing power.

When manual oil temperature regulation is provided, in extremely cold weather excessive oil temperatures are usually the sign of congealing in the cooler rather than excessive heat in the engine. In this case, closing the cooler shutters will thaw the oil in the cooler and restore normal operation.

TRANSITION FROM CLIMB TO LEVEL FLIGHT

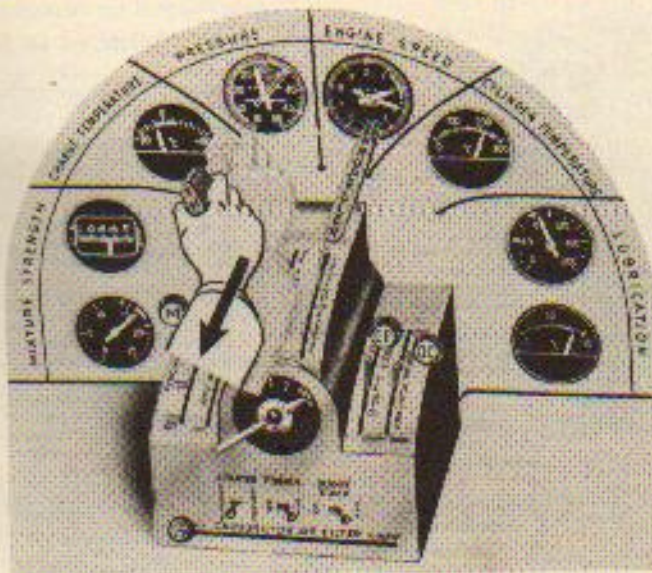

SPEED AND PRESSURE — RPM AND MANIFOLD PRESSURE



Establish level flight power by first reducing manifold pressure and then reducing engine speed. Select a manifold pressure and rpm combination which satisfies the requirements of Fig. 36.

CYLINDER HEAD TEMPERATURE



Delay closing cowl flaps or leaning mixture until the cylinders have cooled down below 400 F (200 C). This delay serves not only to cool the cylinders after the climb but to bring to desirable temperatures the entire powerplant. Close the cowl flaps gradually as the speed increases.

MIXTURE — FUEL-AIR RATIO

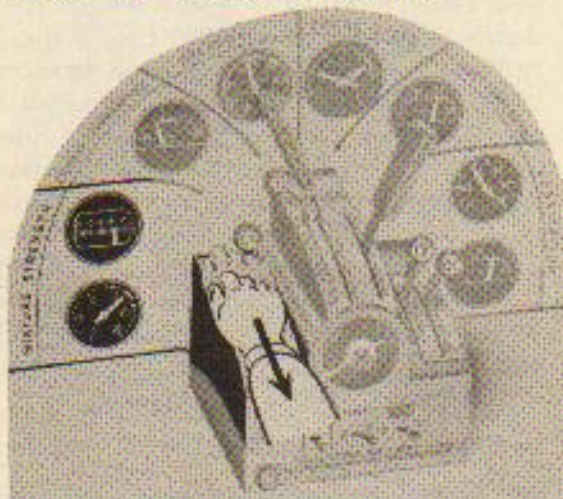

Change to cruising mixture after the engine has cooled and stabilized cruising airspeed has been attained. The mixture is adjusted last to prevent the combination of a lean mixture and a warm engine. An engine that is well cooled will not detonate under cruising conditions, whereas introducing a lean mixture in a warm engine can result in incipient detonation which will prevent the engine from cooling.

LEVEL FLIGHT

Approximately 95% of flight time is spent in this engine operating condition and, therefore, has the greatest influence on engine durability and overall economy.

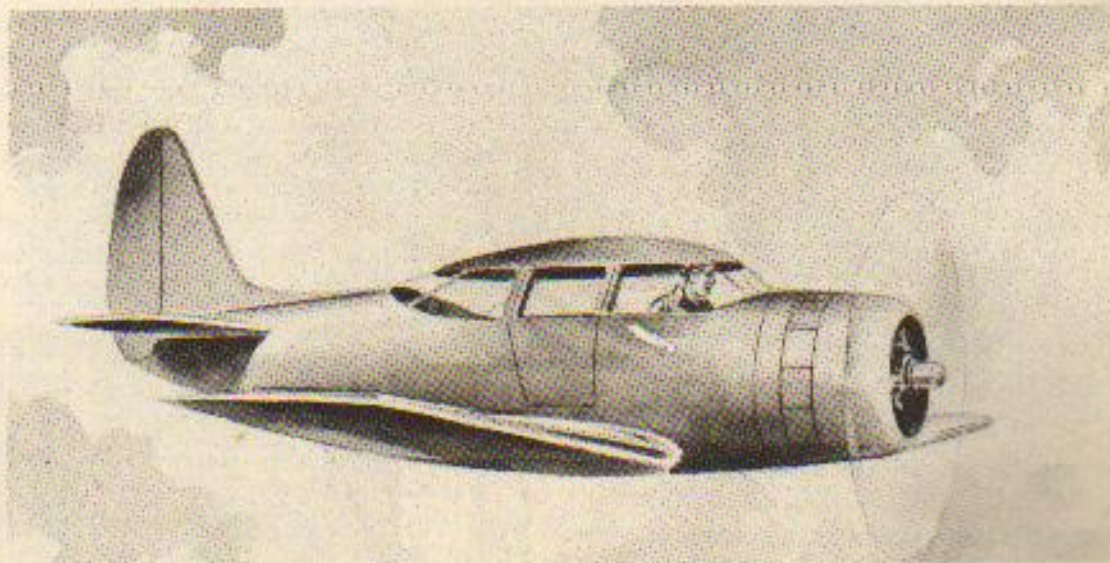

POWER: The lowest power that will give the desired aircraft performance within the following limits:

Maximum

- Military Operation — Military Rated Power (Time Limited)
- All Other — Maximum Continuous Power (Except where special ratings apply)

Recommended Maximum

- All Normal Operation — Maximum Cruise Rating
- Engine service life increases as continuous power is reduced.

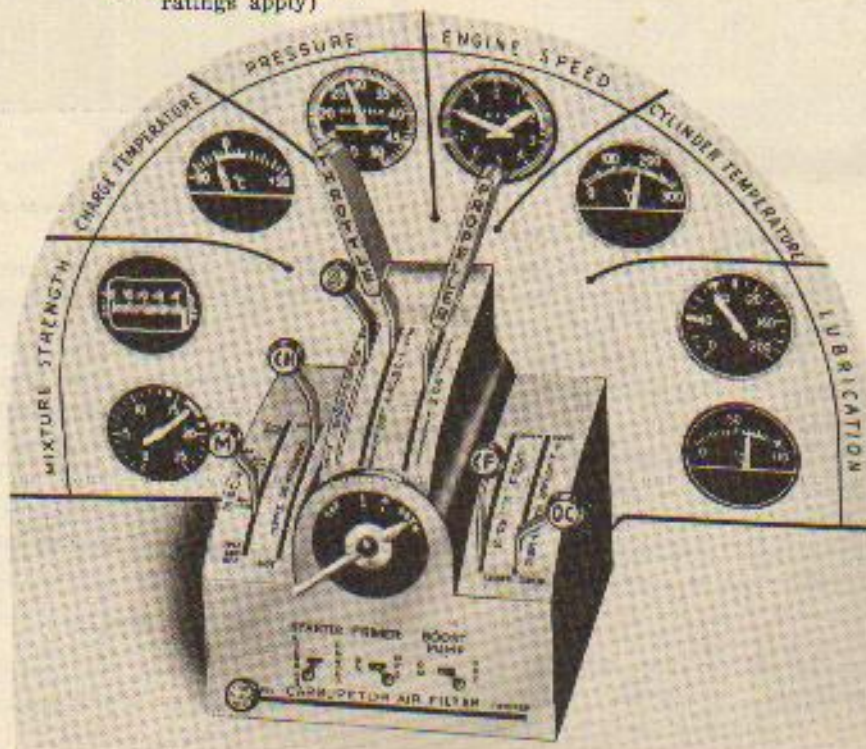

SPEED AND PRESSURE — RPM AND MANIFOLD PRESSURE

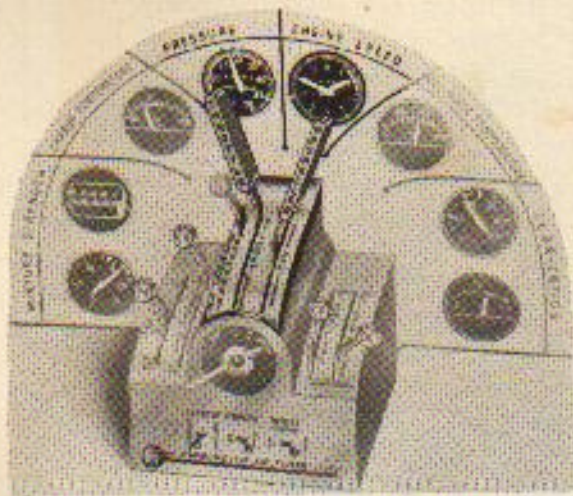

Obtain desired power within bmep limits as shown on Fig. 36. Where aircraft manufacturer has provided complete cruise control information, use his data for precise control.

MIXTURE — FUEL-AIR RATIO

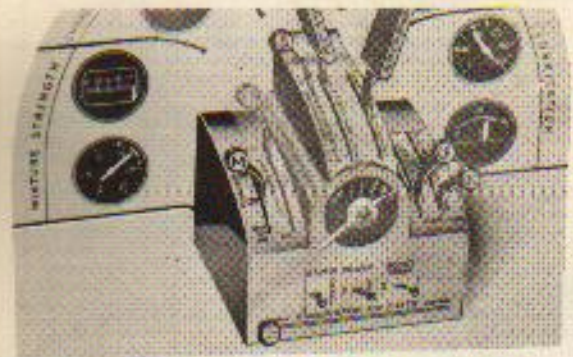

All operation in excess of Normal Rated power must be with rich or automatic rich mixture for continuous operation. For powers below Normal Rated, Pratt & Whitney Aircraft recommends limits for power, rpm and bmep for use with lean mixture. While these recommended limits are not mandatory the use of lean mixture at greater powers should only be attempted on the basis of analysis as to the advantages to be obtained. The use of lean or automatic lean mixture at any time must be reserved for favorable conditions of cylinder and oil temperature.

The use of lean or automatic lean mixture under cruising conditions is essential if the potential fuel economy of the engine is to be

realized. It is intended that cruising lean mixtures be used under favorable conditions of operation. When it is not possible to maintain cylinder temperatures within maximum continuous limits the mixture must be returned to the rich or automatic rich position.

Many pilots have noticed a change of power while holding constant manifold pressure and rpm when reducing the mixture strength to lean values. The loss of power is directly evident, if a torquemeter is installed, or it may be noticed by a slight reduction in airspeed. This drop in output is the normal result of reducing mixture strength below best power

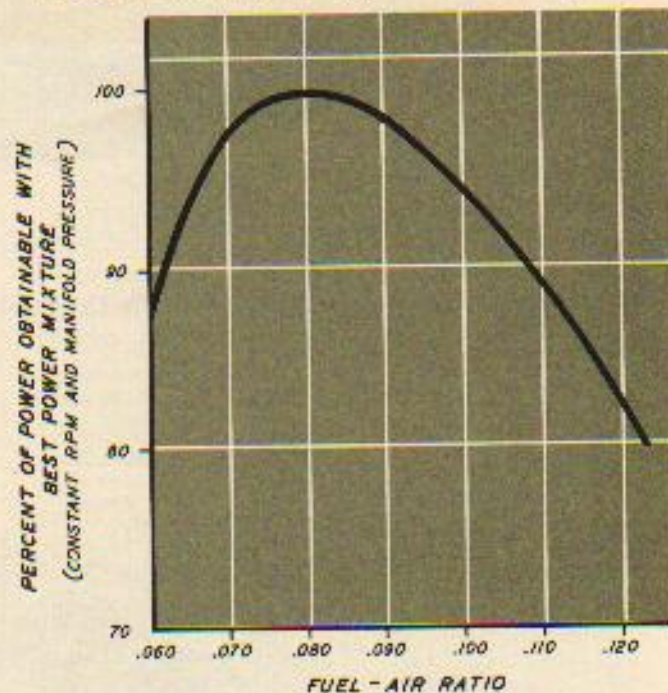

Fig. 39 — Power vs Fuel-Air Ratio

fuel-air ratio and does not mean that the economy of lean mixture operation is being lost.

If the operator has available operating curves covering automatic rich and automatic lean operation, the extra manifold pressure necessary to obtain the desired performance can be readily determined. When such information is not available the throttle should be advanced to regain the airspeed lost when the mixture was leaned.

1. Automatic Carburetors

Current engines, equipped with automatic carburetors, have the lean mixture position indicated as Automatic Lean. When the

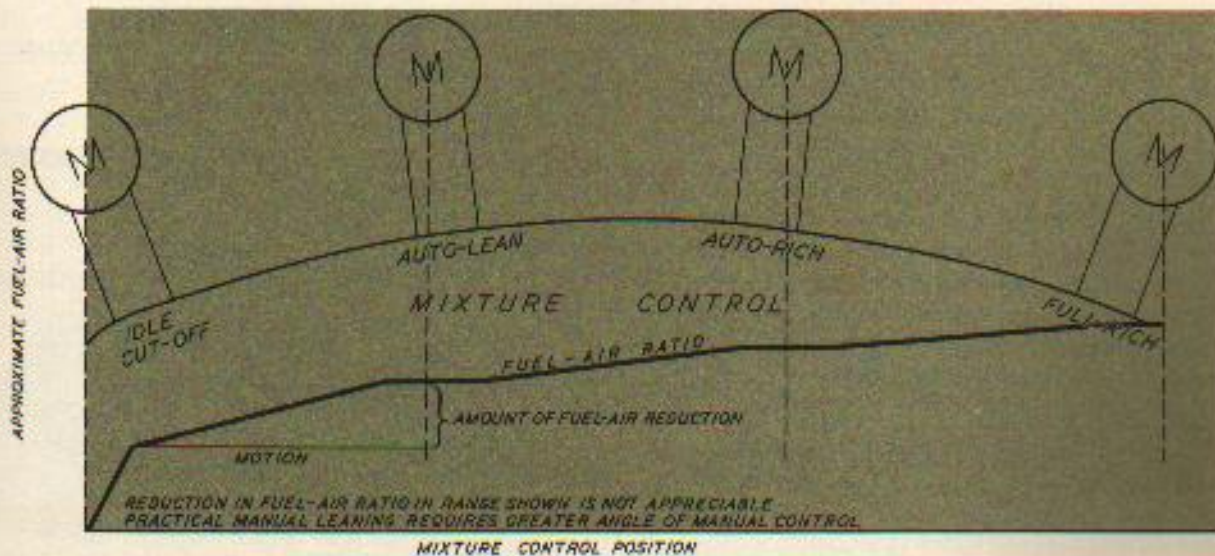

Fig. 40 — Fuel-Air Ratio vs Mixture Control Position

mixture strength is to be reduced the control should be retarded by placing it in the automatic lean position. An automatic lean indent is provided that can be felt during the control motion. (For carburetors with normal and rich positions, refer to Page 31.)

The question is raised in many sources as to the possible advantages of manual leaning between, automatic lean and idle cut-off. On carburetors of previous and current manufacture, this is not a procedure to be attempted except under conditions allowing the closest attention to this operation and in installations provided with instrumentation for the purpose. Furthermore, the relation between mixture control travel and fuel-air ratio is extremely sensitive and such that accurate control is difficult.

It will be seen that a sudden drop in mixture strength occurs with a very slight motion of the control. Under all normal conditions it is, therefore, recommended that lean mixture operation be performed with the control placed in the automatic lean indent.

As new developments take place, individual models of carburetors may be provided with mixture regulation allowing manual leaning and a different nomenclature may be used to distinguish proper mixture positions. For exact information consult the applicable specific operating instruction.

2. Non-Automatic Carburetors

a. With manually controlled two-position, or fixed position propellers:

Referring to Fig. 39, it will be noted that, as the rich mixture used in climb is leaned out, the power developed increases until the rich best power setting is reached; remains virtually constant at a maximum between rich best power and lean best power; and decreases rapidly as the mixture is leaned out beyond lean best power. When a propeller is used which can be held in one pitch position, any change in power is accompanied by a corresponding change in rpm. This relationship is made use of in setting the mixture for level flight as follows:

- (1) Fix throttle to the desired rpm and manifold pressure and adjust carburetor air temperature for continuous operation.
- (2) Lean mixture until rpm reaches a maximum value. This is **rich best power** and is the full extent to which the engine may be leaned when operating between 65-75% power. In leaning to this condition it will be normal to go slightly beyond the point where maximum rpm is first noted. The control must be returned to this point, making sure that control linkage backlash is accounted for.

- (3) Below 65% power the mixture can be reduced to **lean best power** by retarding the control beyond rich best power until the rpm starts to fall off. Do not lean beyond a 10 rpm drop from maximum rpm.

b. With Constant Speed (Variable Pitch) Propellers

As the constant speed propeller prevents any rpm response to power changes caused by mixture variation, mixture regulation must be obtained by other means.

(1) Fuel-Air Analyzer

If a suitable fuel-air analyzer is installed, the mixture can be leaned so that the instrument readings are in accordance with the values specified in the specific operating instructions for the engine.

(2) No Instrumentation

With no instrumentation, manual leaning cannot be done safely as there is no reaction from engine or instrument to advise the operator that safe conditions are being maintained. Manual leaning is permitted only to the extent required to smooth out engine roughness resulting from the effect of altitude on the uncompensated carburetor.

When manual mixture adjustment is used it must be remembered that the control position gives the correct fuel-air ratio only for the conditions under which the adjustment is made, namely: power, rpm, carburetor air temperature, and altitude. If any of these conditions are changed, the mixture must be reset. There is no definite mixture control position corresponding to any specific combination of manifold pressure and rpm, but the following will serve as a formula to enable the operator to maintain a proper mixture strength:

- (a) **Advance Mixture Control (Enrich Mixture) when:**
 Manifold pressure increases,
 Rpm increases,
 Carburetor air temperature decreases,
 Altitude decreases.
- (b) **Retard Mixture Control (Lean Mixture) when:**
 Manifold pressure decreases,

Rpm decreases,
 Carburetor air temperature increases,
 Altitude increases.

CHARGE TEMPERATURE — CARBURETOR AIR TEMPERATURE

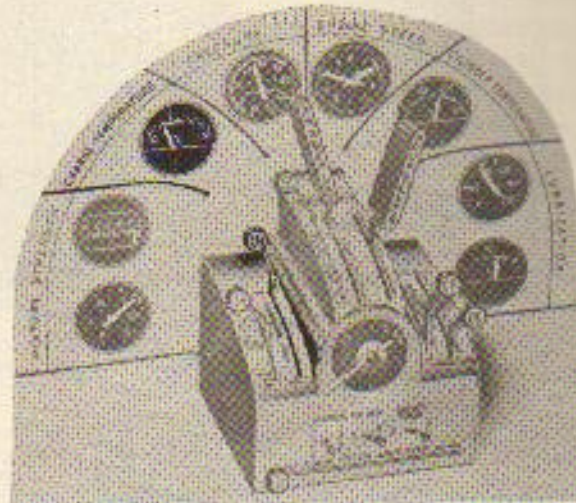

With Wasp Jr, Wasp, Twin Wasp Jr and Hornet engines, or other Pratt & Whitney Aircraft engines using float-type carburetors, it is desirable to maintain a constant 90 F (30 C) carburetor air temperature to ensure freedom from icing and to assist mixture distribution.

On all engines it will be necessary, under ice formation conditions, to increase the carburetor entrance temperature either to eliminate ice already formed or to maintain a carburetor air temperature that will ensure freedom from ice formation. In such circumstances the immediate concern is freedom from ice, but it should be realized that as an indirect result the mixture charge temperature is being increased. The maximum limit, usually 100 F (40 C), must be observed. Refer to the applicable specific operating instructions for the engine in question.

The use of a 100 F (40 C) carburetor entrance temperature will effectively prevent ice formation at all times. However, when ice has formed it may be necessary to use the entire preheat capacity to clear out the induction system. Under such circumstances the engine rpm should be below 85% of Normal Rated speed. After the ice has been cleared, the carburetor air temperature should be reduced to below 100 F (40 C).

There is no minimum carburetor air temperature. Full cold operation in sub-zero conditions can be entirely satisfactory, and as long as ice formation is not encountered there should be no reason to apply preheat, unless the fuel requires some heat to aid in vaporization and distribution as indicated by rough running.

CYLINDER HEAD TEMPERATURE

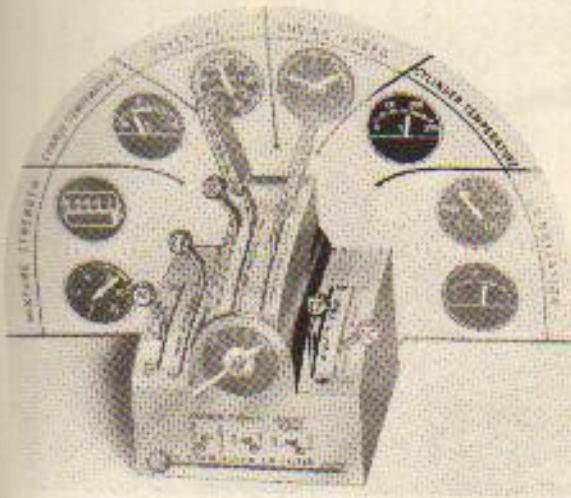

The specified maximum cylinder head temperature for continuous operation is established to ensure prevention of detonation and to maintain the strength of the head and piston material in spite of the high combustion temperatures resulting from a lean mixture. Exceeding this temperature limit with lean mixtures will result in detonation which will materially weaken the cylinder heads and pistons and reduce the life span of the engine. Engine life will be appreciably increased by maintaining cylinder head temperatures below 400 F (200 C), and every effort consistent with aircraft performance should be made to operate below this temperature.

DESCENT

Normally, descent can be considered a continuation of level flight, maintaining the same conditions of power, bmep, and temperature control.

If constant power output has been maintained by increasing the rpm when the critical altitude

is attempted to obtain cylinder temperature control by means of mixture regulation, the operator must bear in mind that a decrease in cylinder head temperature is not always obtained by advancing the mixture control from automatic lean to automatic rich. On many engines carburetors are so adjusted that the automatic-lean position provides approximately best economy mixture strength in the cruising range. At corresponding powers the automatic rich position will result in approximate lean best power mixture strength. Under these conditions in the cruising range automatic lean will result in cooler cylinder temperatures than automatic rich. Above approximately 70% power automatic rich will always result in cooler cylinder temperatures than automatic lean.

LUBRICATION

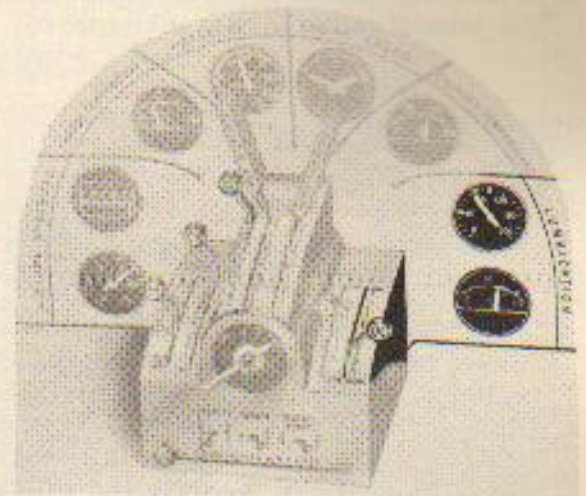

The procedures outlined under Climb apply equally to Level Flight.

for the normally selected rpm and manifold pressure was passed, maintain the desired power during the descent by reducing the engine speed by 50 rpm for each in. Hg gain in manifold pressure. After passing the normal setting critical altitude, regulate power by throttle adjustment.

GLIDE AND APPROACH



The transition from cruising descent to glide and approach occurs at the time that the aircraft is slowed down for extending the undercarriage and when entering the airport flight pattern. From this point until actually landing, the pilot will want the engine in a condition to respond immediately to any demand for power, from a moderate increase for maneuvering to full take-off rating in case of emergency.

SPEED — RPM

As Take-off rated rpm may be required in case full power is needed, the propeller control should be advanced to a position which will result in 85-90% of Normal Rated rpm when the propeller is governing. The control is not advanced to the take-off rpm position, as a sudden throttle opening would result in serious overspeeding which may amount to 600-800 rpm with some propellers. If the need for full power does occur, advancing the throttle will give immediate power response and the rpm control can be adjusted later.

With two-position propellers, the rpm control should be placed in the high rpm position. With either two-position or constant speed propellers, the control position should be adjusted at an aircraft speed sufficiently low so that overspeeding does not result.

PRESSURE — MANIFOLD PRESSURE

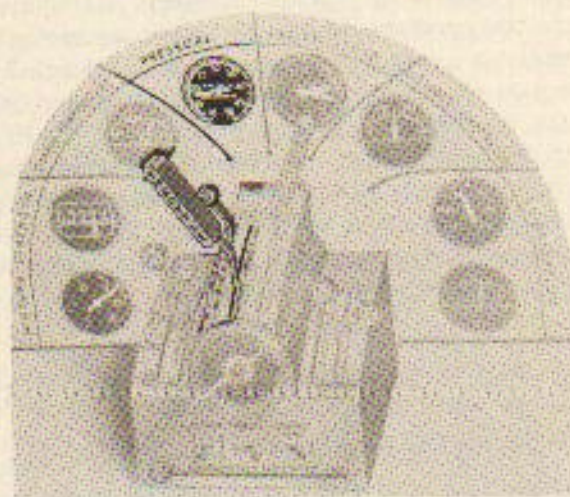

As a variable pitch (constant speed) propeller will be in fixed low pitch at the low power used, engine power control will be obtained entirely by the use of the throttle.

MIXTURE — FUEL-AIR RATIO

Rich mixture will be required for the remainder of the flight to obtain satisfactory acceleration response and to ensure engine protection in case of a sudden need for full power.

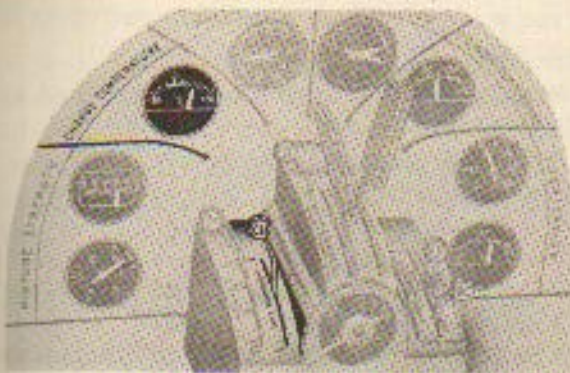
CHARGE TEMPERATURE — CARBURETOR AIR TEMPERATURE

Under conditions leading to ice formation, maintain 100F (40C) carburetor entrance temperature. In the event of a sudden application of full power, the carburetor heat control must be readjusted immediately, as the increase in power will cause a rapid rise in the available carburetor heat.

CYLINDER HEAD TEMPERATURE

The cowl flaps, where used, should be open slightly (trail position on some installations).

The remainder of the flight is at low airspeed and the airflow is needed for ignition system cooling. In case there is a demand for full power, the engine will receive sufficient cooling to prevent a serious temperature rise, and the cowl flaps can be later readjusted after taking care of more urgent items.

LUBRICATION

Where manual oil cooling control is provided, adjust shutters to maintain the desired temperature condition.

CHECK LIST

As in preparation for take-off, a landing check-off list is recommended:

- | | |
|-----------------------|---|
| 1. Mixture | — Rich (Automatic Rich) |
| 2. Rpm | — 85-90% Normal Rated |
| 3. Fuel Selector | — On suitable tank* |
| 4. Carburetor Heat | — Cold; or 100F (40C) if icing conditions are present |
| 5. Cowl Flaps | — Trail or 2 in. open |
| 6. Oil Cooler Control | — As needed |

*Experience has shown that this item cannot be mentioned too often.

LANDING



The cowl flaps are to be opened as soon as it is practical during the landing roll to remove any obstruction to the dissipation of the heat stored up in the engine and to be prepared for taxiing.



SHUTDOWN



With the cowl flaps fully open the engine should be idled for a sufficient length of time to cool the cylinder head temperatures to below limiting shut-down temperatures 400 F (200 C). Shutting down a warm engine results in leaving an excessive amount of heat stored in the mass of the engine, with no means of conducting it away except by convection currents.

Shutting off the engine is accomplished as follows:

1. Shut off booster pump (if applicable).
2. Move mixture control to idle cut-off or full lean, with the throttle open to any idling speed.

Note: It is not necessary to open the throttle as the engine cuts off.

3. When the engine stops rotating, turn off the ignition
4. Leave cowl flaps fully open for at least 15 minutes.

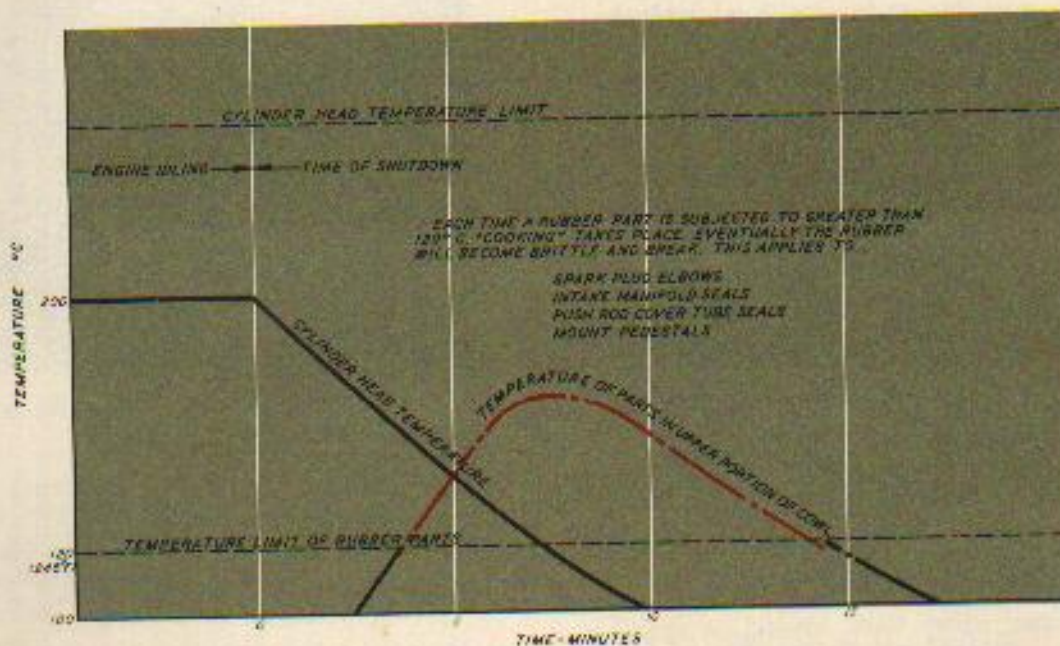
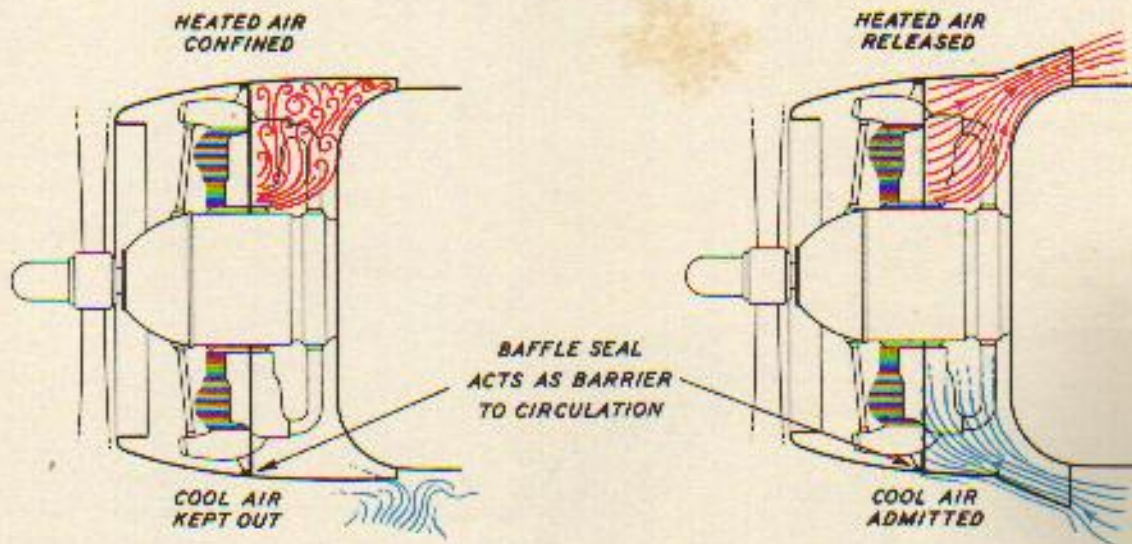

Fig. 41 — Engine Temperatures After Shutdown



Even though the engine is properly cooled prior to shutdown, it still contains a large amount of heat, and it takes a considerable time to remove the heat that is stored in the mass of metal. The only means of removal are the convection currents set up within the cowl. Cool air enters the lower portion of the powerplant and rises to the top of the engine compartment. Unless a ready exit is available, this heated air remains static at a temperature which will damage the ignition harness.

As the mixture control lever is moved into idle cut-off or full lean, an opportunity is afforded to check the idling mixture as discussed

under ground tests.

If the engine does not stop with the mixture control in idle cut-off or full lean:

1. Close throttle.
2. Shut off booster pump (if applicable).
3. Cut ignition.
4. Slowly open throttle.
- (5. Have idle cut-off checked)

Opening the throttle, with the ignition cut, leans the mixture to a point where combustion cannot be maintained.

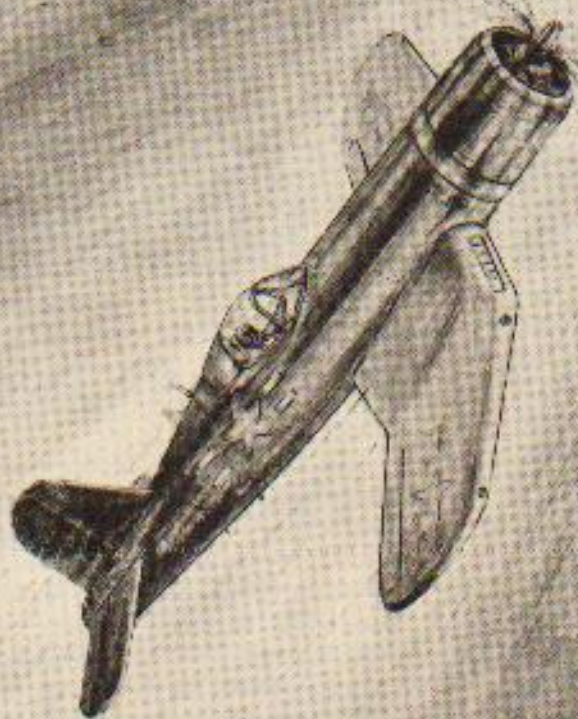

ADVANCED SUPERCHARGING

ADVANCED SUPERCHARGING

FOREWORD

A pilot was preparing to take off in an airplane powered by an engine equipped with a two-stage, two-speed supercharger. He was a conscientious pilot and, noticing that his carburetor air temperature gage was indicating very close to 40C, he recalled an instruction which stated that in such circumstances, a different degree of supercharging should be used. Taking this instruction literally, he changed the degree of supercharging in the only available direction: That is, he shifted from "neutral" to "low" and intently peered at the carburetor air temperature gage. The lack of change on this instrument didn't fool him. He shifted from "low" to "high." As there was still no change, he made a decision, logical to him, that it apparently made no particular difference which stage of supercharging was being used. So he took off with the auxiliary stage engaged in high ratio. After getting back to the ground by the "skin of his teeth" it can be imagined that this pilot then realized that ignorance is not always bliss.

In this demonstration the pilot violated the following procedures for the use of the two-stage, two-speed engine:

1. He attempted to obtain power by use of the auxiliary stage under conditions where the auxiliary stage cannot possibly provide airflow to the power section.
2. He reduced the power furnished to his propeller by the amount required to turn the auxiliary supercharger.
3. He engaged his auxiliary supercharger 8000 feet below the altitude where it is advantageous to use the auxiliary stage.
4. He engaged the auxiliary stage under air temperature conditions which would have very probably resulted in detonation if the auxiliary stage could have supplied air to the carburetor.
5. And, most important, he did not know what he was doing.

In extenuation it must be stated that no provision had been made to provide him with information essential to a proper knowledge of the functioning and control of this type of supercharger.

The supercharger described in the chapter on the Induction System is a single-stage, single-speed supercharger and its effect upon engine operation is relatively small. Other than the observance of necessary limits of manifold pressure and carburetor air temperature, its addition to the engine does not require different considerations than would apply to an unsupercharged engine.

The never-ending search for means to increase the altitude range of aircraft performance soon exhausts the abilities of engines equipped with such simple air compressors and more complex systems must be used. Each step of additional supercharging capacity increases the proportion of the engine's operating characteristics that are directly affected by supercharging, and it becomes increasingly essential that the operator understand the final effect on power section functioning as the result of using the supercharger controls.

The title "Advanced Supercharging" is used advisedly. The reader should not be misled into expecting a profound treatise dripping with the erudition of the design room and the development laboratory. The following pages deal with the subject using only those factors which are of direct cockpit interest and control.

Before going to the next step in supercharging it is well to retrace the original discussion in order to examine more thoroughly the significance as to operation of the supercharger and to introduce new factors which must now be included.

PURPOSE OF SUPERCHARGING

Airplane "A" will go 285 mph while airplane "B" is capable of 235 mph. At first glance "A" must be superior to "B." However, without the qualification of an additional factor, the comparison is of little value. At what altitude will airplanes "A" and "B" attain these maximum speeds? If airplane "A" must go to 20000 feet to be able to go 285 mph and "B" can do 235 mph at sea level, "B" is probably superior at low altitude while "A" must go to considerable height before it can take the lead. The reason for these variations in performance lies in the effect of altitude on airplane speed, and in the ability, or lack of ability, of the engine to maintain a given power to the desired altitude of operation. The

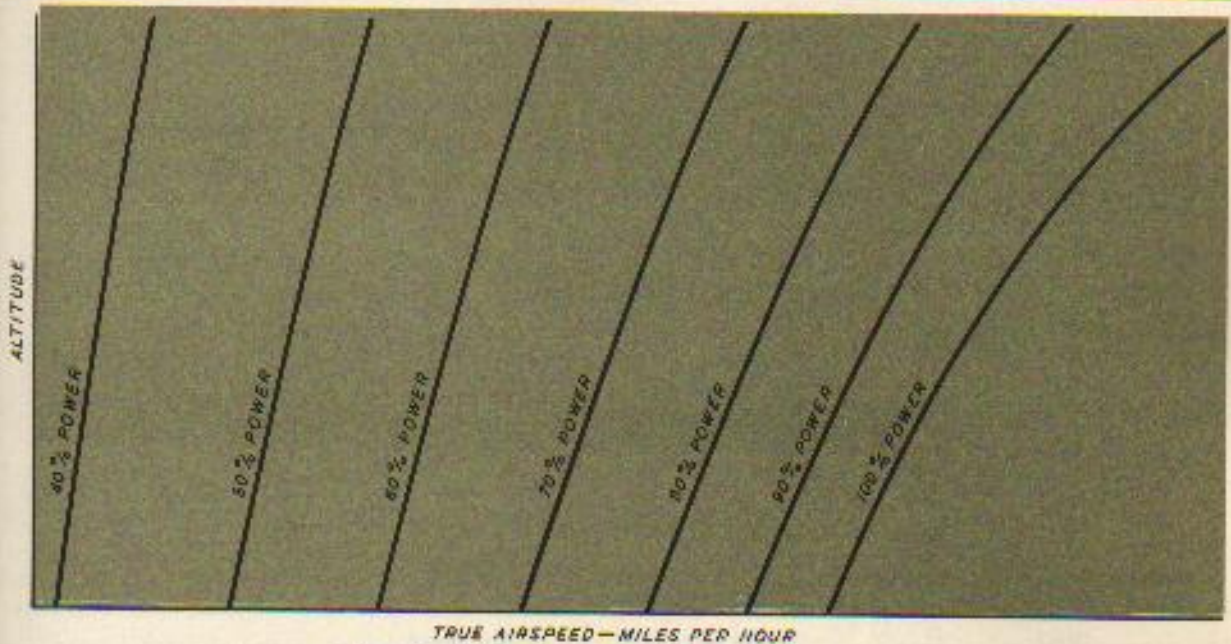

Fig. 42—Altitude vs Airplane Performance

degree of supercharging is of greatest importance in enabling the engine to deliver its power at altitude.

AIRPLANE PERFORMANCE VARIATION WITH ALTITUDE

If, as altitude increases, engine power can be maintained, a gain in level flight high speed will be obtained at the rate of, roughly, 1% per thousand feet. In each cubic foot of air at higher levels there are fewer particles of air to impinge against and retard the airplane, whereas the constant speed propeller makes it possible to sustain approximately constant

thrust. The variation in airplane forward speed with altitude at various percents of power is shown in Fig. 42.

ENGINE PERFORMANCE VARIATION WITH ALTITUDE

As the power delivered by an engine varies with the amount of air it consumes, the performance will fall off as altitude increases when operating with a fixed throttle position and constant rpm. The volume of air drawn into the cylinders will remain unchanged but the weight of this volume and, consequently, the power generated, will diminish in proportion to the air density as shown in Fig. 43.

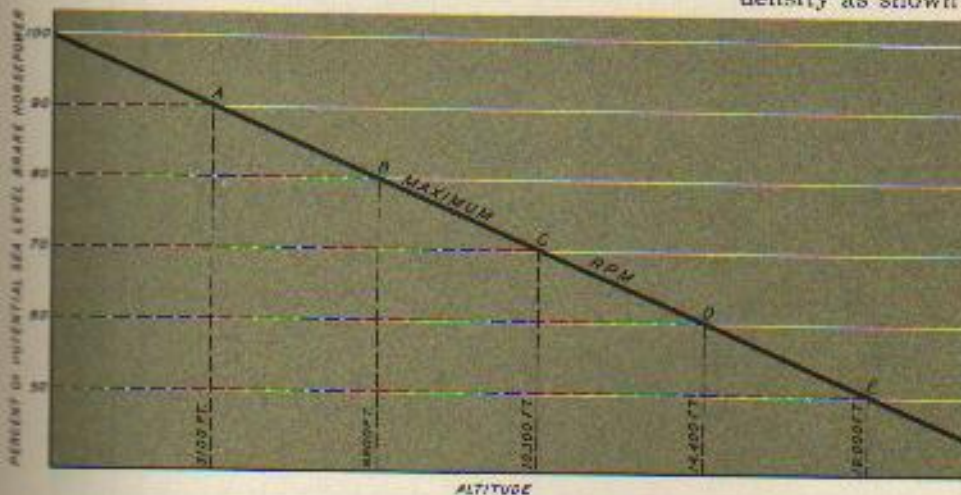

Fig. 43—Engine Performance vs Altitude

This is not 100% of power as defined by the engine rating; it is 100% of the power obtainable at sea level with wide open throttle and at a constant rpm. With supercharged engines, normal rated power (100% rated power) is usually less than 100% of full throttle sea level power. The relation shown is fundamental for all engines, supercharged or unsupercharged, provided that the impeller is driven at a fixed ratio to crankshaft speed.

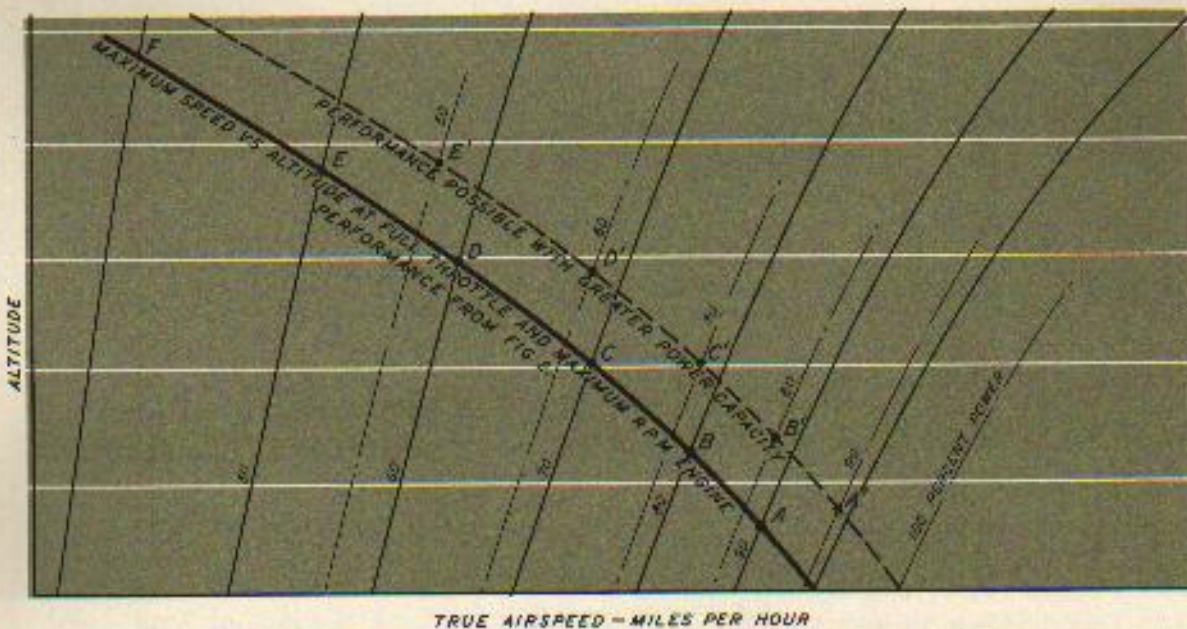

Fig. 44 - Combined Airplane and Engine Performance vs Altitude

COMBINED AIRPLANE AND ENGINE PERFORMANCE

By combining Figures 42 and 43 it is possible to determine the altitude range of performance obtainable with a given airplane and engine combination. For example, point "D" on Figure 43 can be directly transferred to Figure 42 by placing it on a point having the same value of power and altitude. Similarly, the remaining points of Figure 43 are transferred and form

line A-B-C-D-E-F. Line A-F then becomes a curve of the performance obtainable with the airplane and engine combination using the rpm shown and at full throttle. If the engine speed is the maximum allowable the airplane is capable of the performance shown below line A-F. If performance above line A-F is required, the engine power capacity must be increased. It is the function of the supercharger to enable the engine to have this increased power capacity.

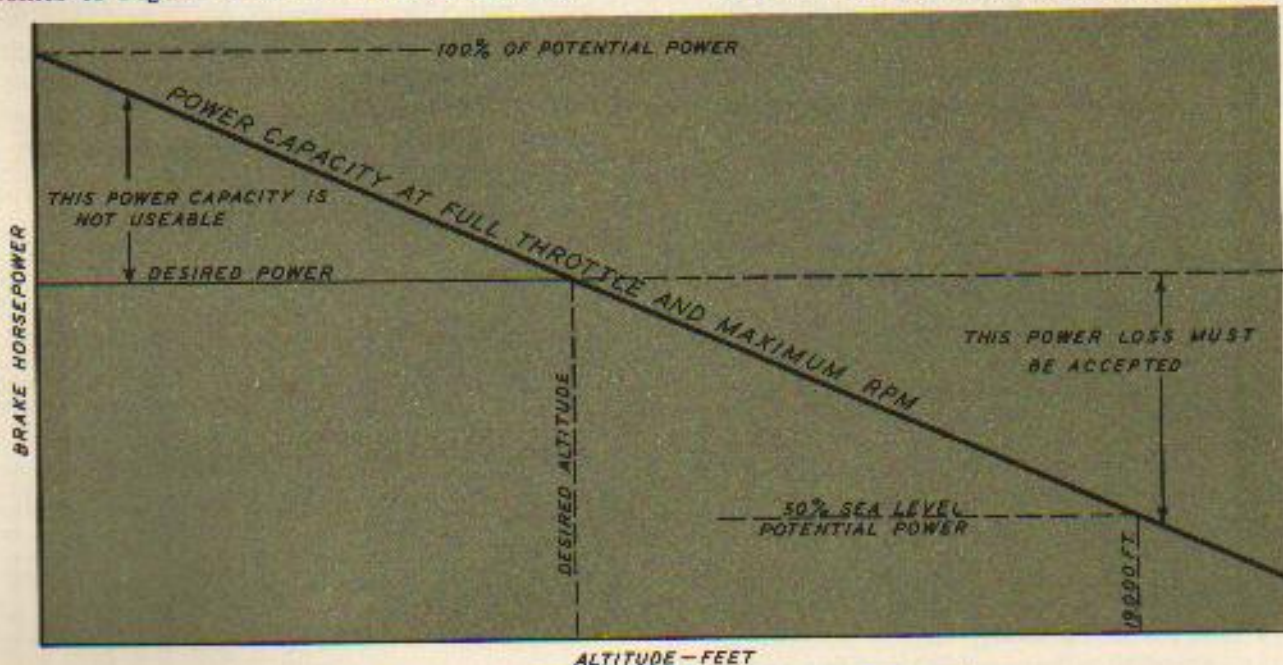
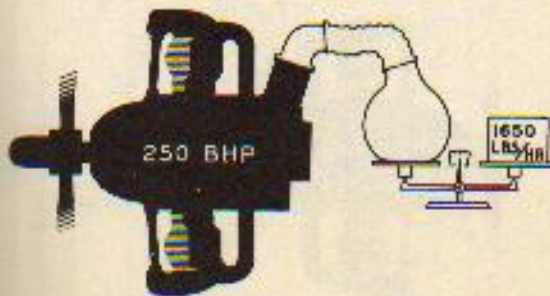

Fig. 45 - Range of Restricted and Unrestricted Operation

If the airplane designer's wishes could be followed, the limits imposed by nature would be pushed back and the engine designer would provide a powerplant capable of delivering constant power unvarying with altitude. However, as the facts of atmospheric life are inexorable, the engine performance will invariably follow the path shown in Figure 43. If the desired power must be obtainable at 10,000 feet the engine capable of meeting this requirement can give 1.4 times the desired output at sea level and, at 20,000 feet, will produce but 68% of this power. Therefore, the engine designer must base his design on what power is required at what altitude. The excess power available at lower altitudes must be kept in check by proper observance of limits and the operator must accept the diminished output at higher altitudes.

INCREASING ENGINE POWER CAPACITY

As the power developed in the cylinders of the engine depends directly upon the lbs. per hour of air consumed, the need for increased power is met by increasing the engine's air-consuming capacity.



LOW AIR CONSUMPTION

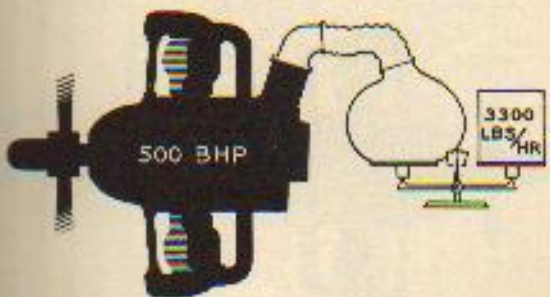

HIGH AIR CONSUMPTION

This increased capacity demand can be met by

1. Increasing the

- a. Size of the cylinders



- b. Number of cylinders

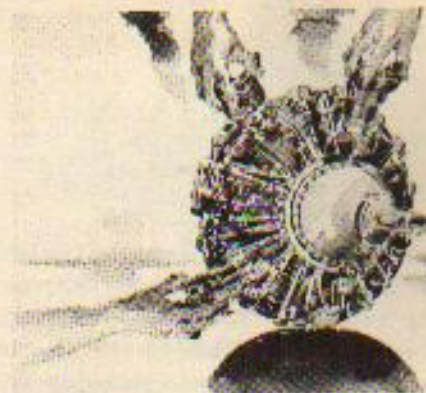

Objection—Size: Extra size of engine results in excessive airplane drag.

2. Increasing the rpm

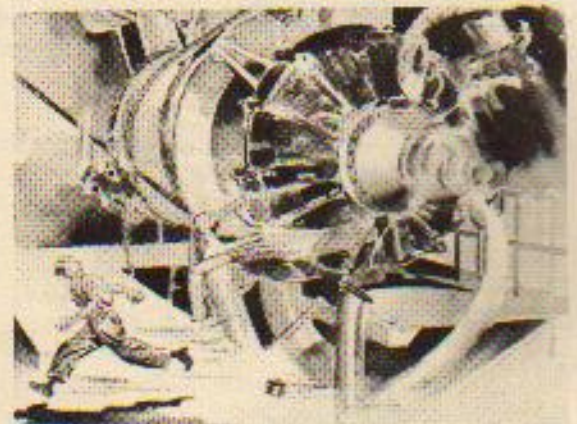

Objection—Centrifugal and inertia loads become excessive and valve action is something different than provided for by cam profile.

3. Supercharging

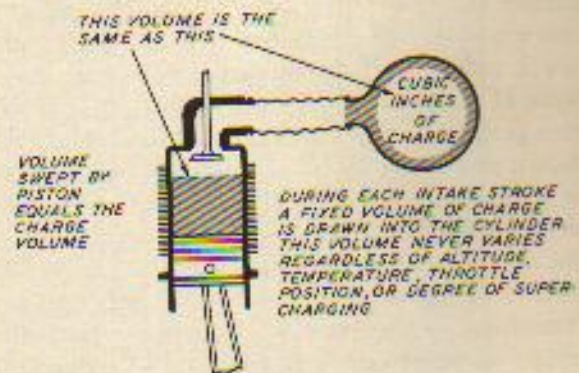
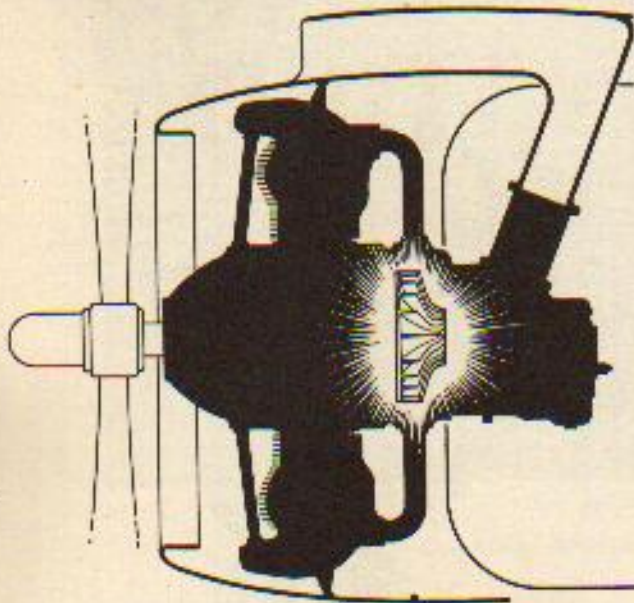

The power that this charge develops in the cylinder depends upon the volume of atmosphere that is compressed into this fixed charge volume which can be varied by—

1. Change in charge pressure which can be varied by
 - a. Throttling

Supercharging offers the most efficient means of increasing engine's air-consuming capacity. It accomplishes the same results as increasing the size or number of cylinders or increasing the rpm but it accomplishes these results with the least increase in weight or size of the powerplant.

The following table illustrates the variations in required size of an unsupercharged engine in order to maintain 1000 hp to various altitudes assuming constant rpm, compression ratio and spark advance.

Altitude	Sea Level	20000Ft.	40000Ft.
Altitude Power Capacity	1000	1000	1000
Full Throttle Power Capacity at Sea Level	1000	2083	6410
No. of Cylinders of Same Size Required	14	29	90

POWER, FROM AIR ENTRANCE TO THE PROPELLER

To repeat, the power developed in the cylinders is directly proportional to the WEIGHT of air drawn into the cylinders. "Weight" is emphasized as this is the only factor that can be varied, holding constant rpm. Volume cannot be varied.

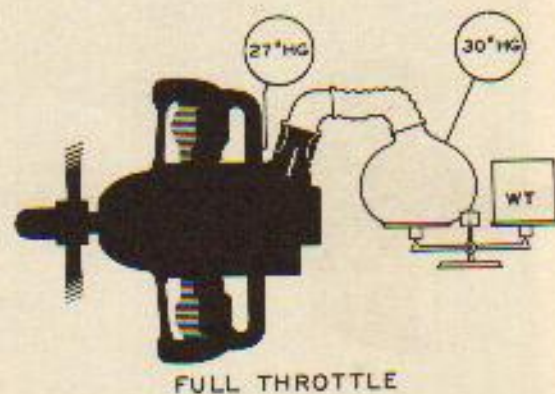
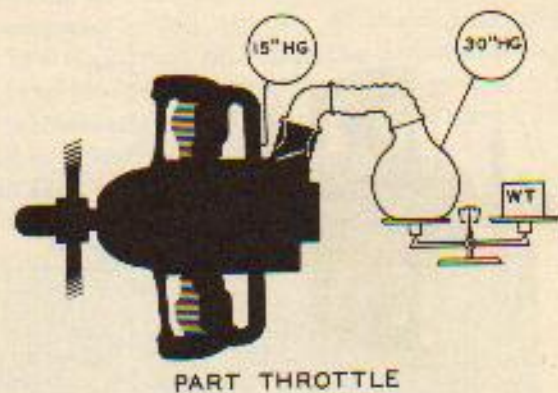

- b. Change in carburetor entrance pressure resulting from changes in altitude

ADVANCED SUPERCHARGING

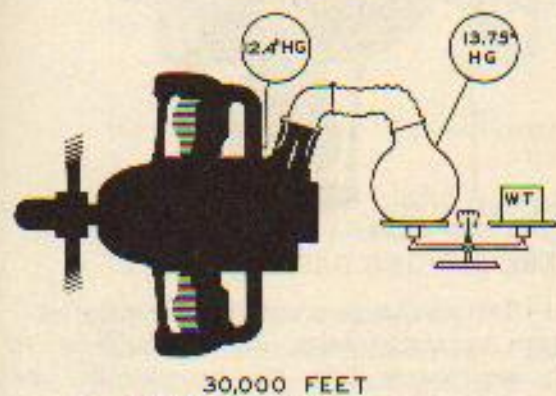
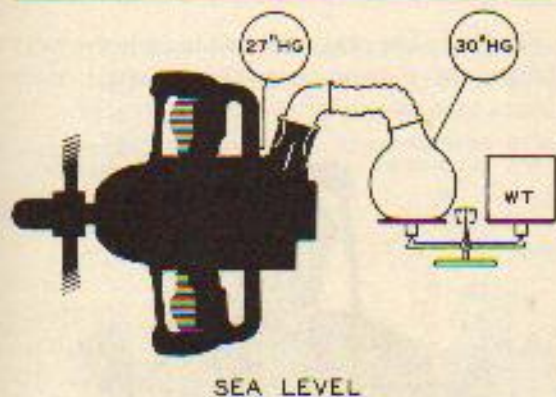

c. Supercharging

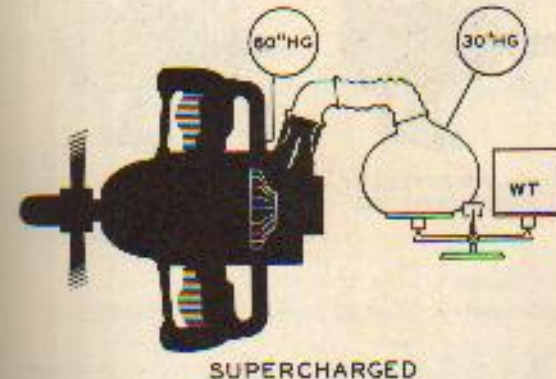
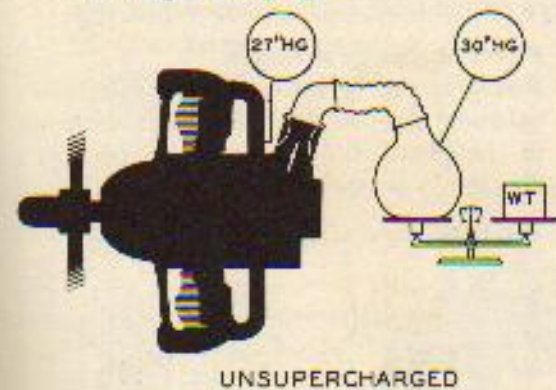

An increase in the pressure of the charge is a favorable factor in increasing the weight of the charge and, consequently, increases the power developed in the cylinders.

PURPOSE OF SUPERCHARGING

2. Change in charge temperature which can be varied by—
 - a. Change in atmospheric temperature

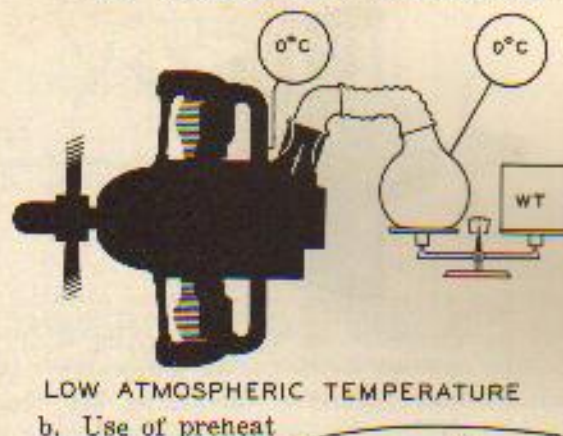
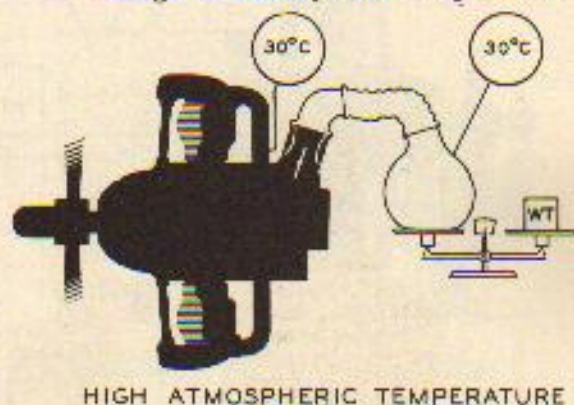

b. Use of preheat

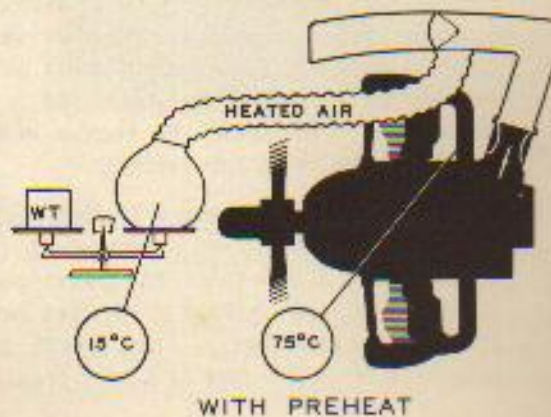
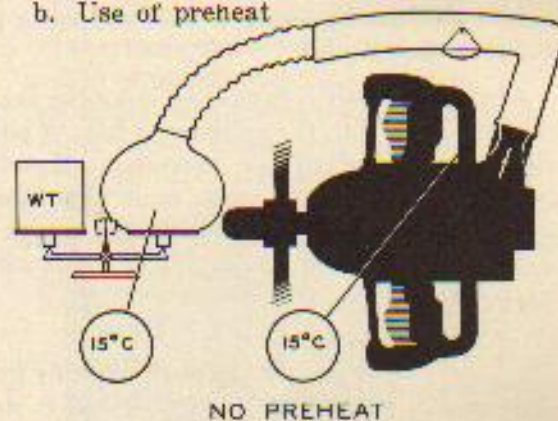

c. Supercharging

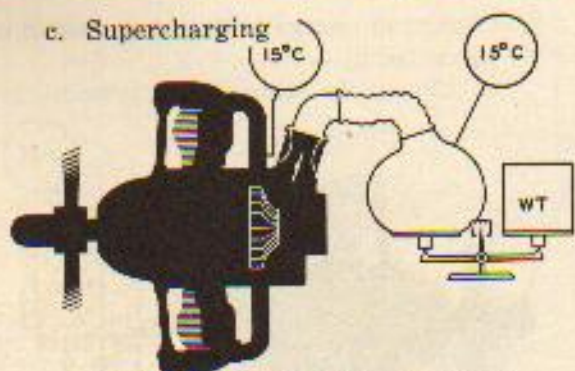

SUPERCHARGED BUT WITHOUT ACCOMPANYING TEMPERATURE RISE
A PURELY IMAGINARY CONDITION

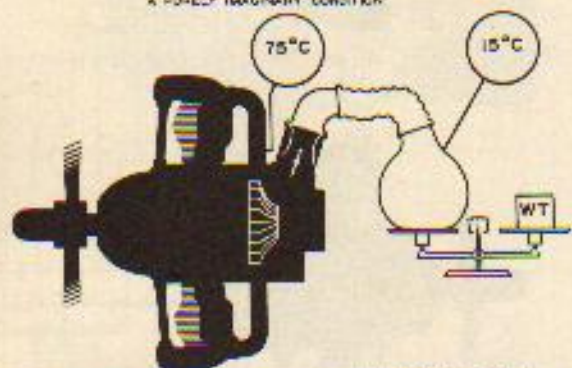

SUPERCHARGED WITH UNAVOIDABLE ACCOMPANYING TEMPERATURE RISE

Any increase in the charge temperature is an unfavorable factor in increasing the charge weight and, consequently, lowers the power produced in the cylinder.

After the power is developed from the charge that is drawn into the cylinder, a flow of power (ihp) starts toward the propeller. However, contributions must be made from this flow to power-absorbing agencies within the engine before the useful balance available at the propeller shaft can be measured. These are:

1. Friction horsepower

The power expended to overcome the internal friction within the engine and to drive the various engine accessories. While, in practice, this item is of appreciable magnitude, it does not vary to any great extent because of changes to be considered in this discussion. Therefore, the engine will be considered as being frictionless.

2. Supercharger horsepower — (often lumped together with friction horsepower)

The impeller is able to expend power on the incoming charge because it receives power from the crankshaft. This power is a diversion from the flow of power from the

cylinder to the propeller and is an important factor in determining the over-all gain from supercharging.

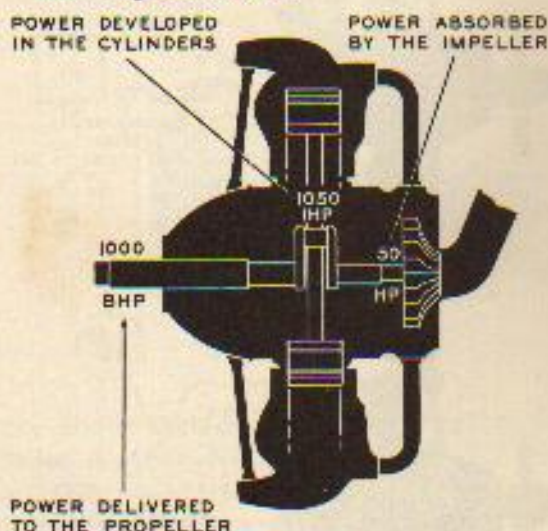

SUPERCHARGING BASIC FACTORS

The effect on charge pressure and charge temperature by compression, and the amount of power required to drive the impeller are the three principal measures by which a comparison can be made of various superchargers.

1. Effect on charge pressure

Measured by pressure ratio — the ratio between the pressure at the air entrance to the pressure at the supercharger exit (manifold pressure).

$$\text{PRESSURE RATIO} = \frac{\text{MANIFOLD PRESSURE}}{\text{ENTRANCE PRESSURE}}$$

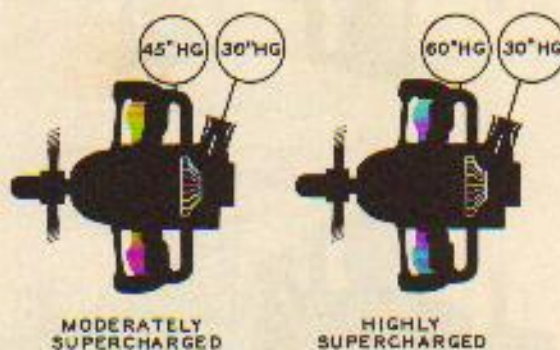

$$\text{PRESSURE RATIO} = \frac{45}{30} = 1.5:1 \quad \text{PRESSURE RATIO} = \frac{60}{30} = 2:1$$

It is sufficiently accurate for the purpose of this discussion to assume that these pressure ratios will remain constant with change of altitude. (Actually, there is a small percent of increase with altitude

which would not add enough to the accuracy of this presentation to be recognized). For example, at 19000 feet the entrance pressure is 14.3 in. Hg.

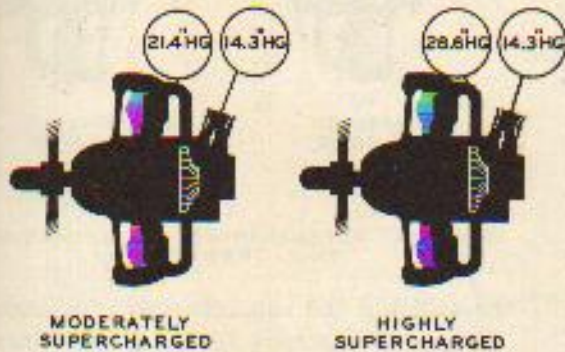

$\text{PRESSURE RATIO} = \frac{21.4}{14.3} = 1.5:1$
 $\text{PRESSURE RATIO} = \frac{28.6}{14.3} = 2:1$

2. Effect on charge temperature

Measured by temperature rise — the difference between the temperature of the charge at the entrance and the charge temperature at the supercharger exit. This rise is the inevitable result of compression together with unavoidable fluid friction and turbulence.

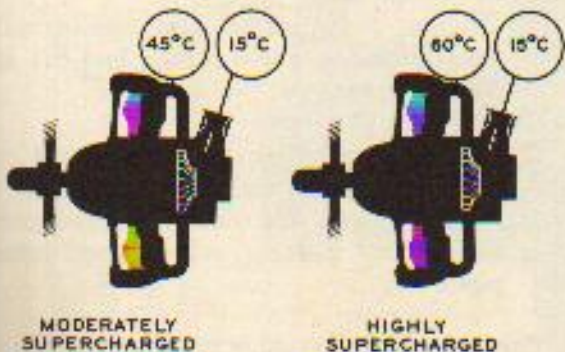

$\text{TEMPERATURE RISE} = 45^\circ - 15^\circ = 30^\circ\text{C}$
 $\text{TEMPERATURE RISE} = 60^\circ - 15^\circ = 45^\circ\text{C}$

As with the case of pressure ratios, it will be assumed that temperature rises remain constant at a given rpm regardless of changes in air entrance temperature, airflow as controlled by throttle position or airflow as determined by the altitude of operation. Actually, there is but a slight deviation from this assumption.

For example: at 19,000 ft. the temperature of the air at the entrance is -23°C .

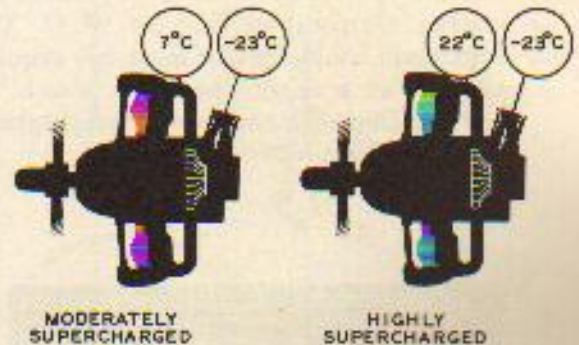

$\text{TEMPERATURE RISE} = +7^\circ - (-23^\circ) = 30^\circ\text{C}$
 $\text{TEMPERATURE RISE} = +22^\circ - (-23^\circ) = 45^\circ\text{C}$

Besides its effect on power, the charge temperature is a very important measure of the tendency of the charge to detonate. For any grade of fuel a close relationship exists between the temperature and the pressure of the charge which defines the limit of normal safe combustion. If the charge pressure is low it can tolerate a high temperature, or, conversely, if the temperature is low a high pressure can be safely imposed.

The limits resulting from this relationship can be shown graphically as follows:

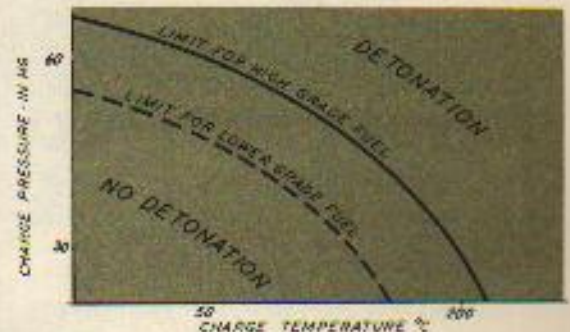
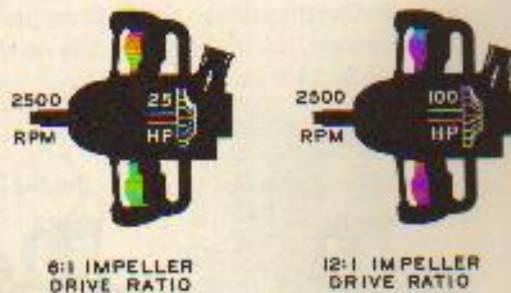

Fig. 46 Charge Temperature vs Detonation

The implication of Figure 46 above is that, as the charge temperature is increased, it becomes necessary to prohibit the use of that portion of the engine's power capacity that lies in the detonation range.

For example, if the engine must be capable of operating at sea level with a carburetor air temperature of 40 C and the supercharger heat rise is 45 C the resulting charge temperature will be 95 C. The maximum usable power must not require the use of a charge pressure, which, in combination with the charge temperature of 95 C, will produce detonation.



18,000 FEET SUPERCHARGER HORSEPOWER AT FULL THROTTLE

In utilizing the supercharger, the engine designer is reaching for the goal of maximum power sustained to the highest possible altitude. By supercharging, he is endeavoring to obtain the maximum benefit from the resulting increased charge density without being penalized excessively by restrictions resulting from the increased charge temperature.

The step by step development of the supercharging systems that follows uses the same engine components tabulated below. All operation is at constant rpm.

1. Power Section

Cylinder displacement, compression ratio, spark advance, valve timing and lift and fuel-air ratio.

2. Basic supercharger section (except un-supercharged engine)

Impeller design and diameter, supercharger entrance, diffuser, collector and intake pipes.

The only variable used is impeller speed with the exception of the two-stage engine.

Whereas many of these factors would be varied to obtain desired altitude performance, they are design factors and not subject to cockpit control. The purposes of this book can best be served by following the effect of the one variable over which the operator has control.

In the following pages a comparison is made of the different forms of supercharging normally used. The different factors involved are shown in this form.

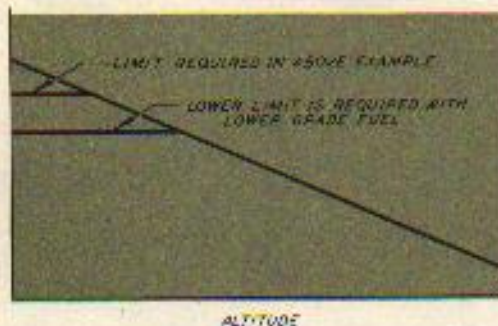
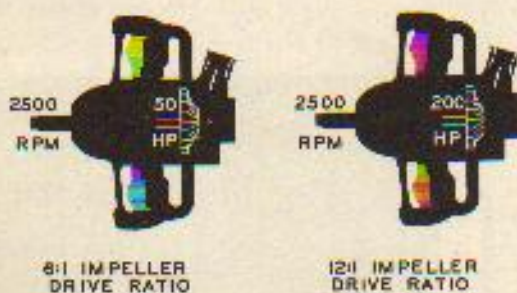

Fig. 47 — Necessary Power Restrictions for Detonation-Free Operation

3. Supercharger horsepower

The power absorbed by the impeller varies as the square of the velocity at the impeller rim. With a given impeller this variation will be as the square of the rpm.



SEA LEVEL SUPERCHARGER HORSEPOWER AT FULL THROTTLE

This discussion will be based on the premise that at constant rpm supercharger horsepower diminishes with altitude in proportion with the decrease of brake horsepower. This is accurate within the limits of accuracy of the assumptions of constant pressure ratio and constant temperature rise.

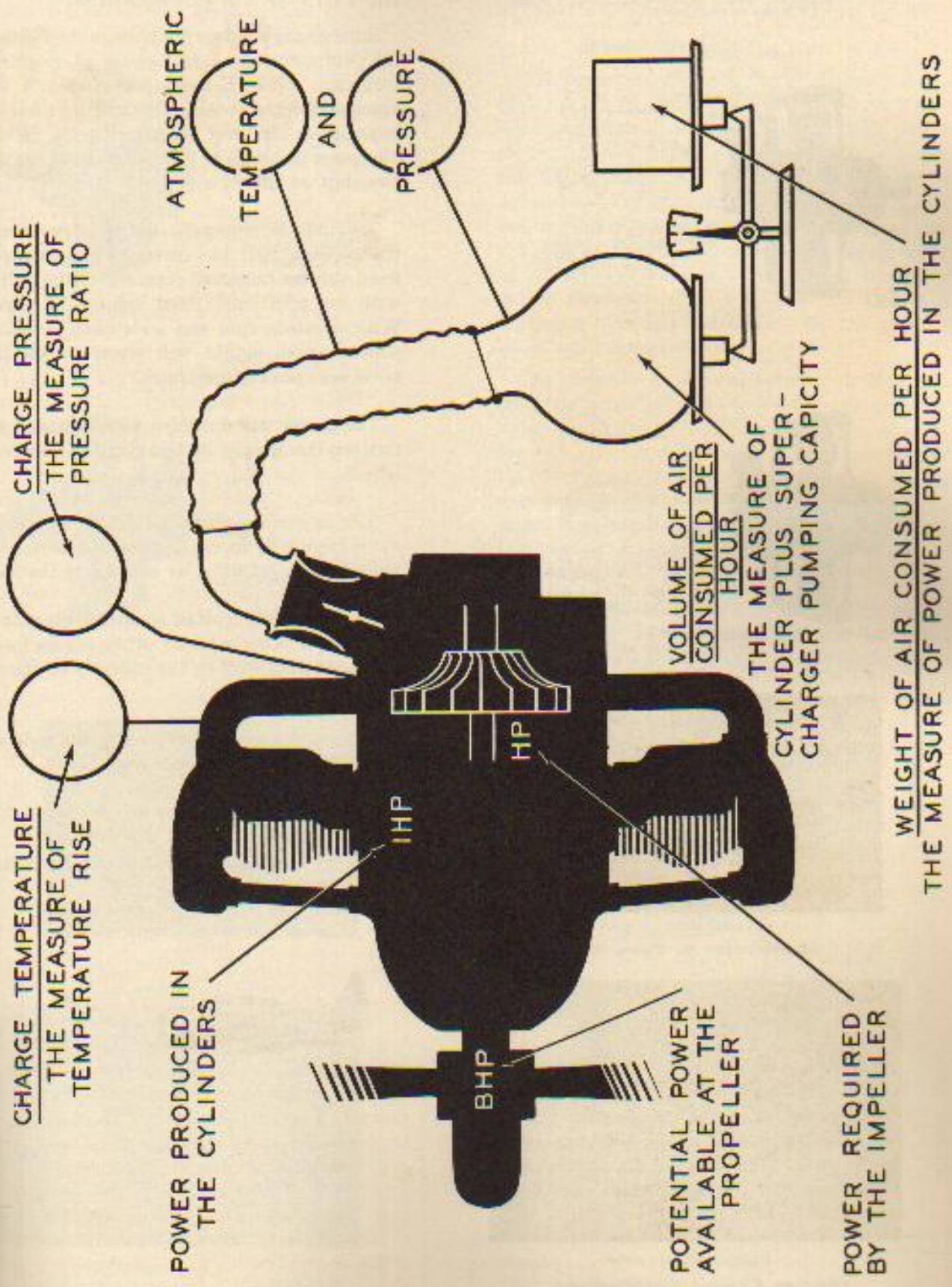

TYPICAL UNSUPERCHARGED
(NORMALLY ASPIRATED)

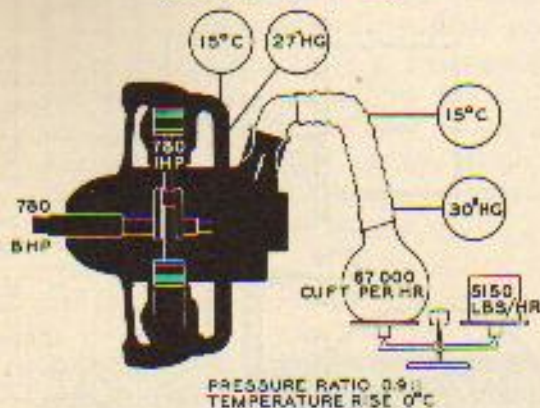

TYPICAL SUPERCHARGED

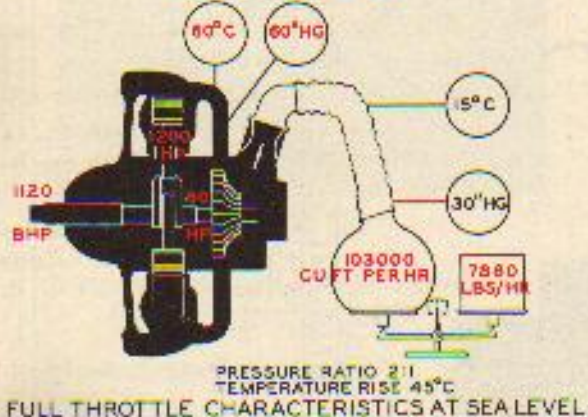

RESULTS OF SUPERCHARGING

Supercharging does not change the fundamental performance characteristic of engine performance with change of altitude. A supercharged engine obtains 100% of its total power capacity at sea level. At any altitude, full throttle power at constant rpm follows the same relationship, as shown in Fig. 43.

This will be understood if it is realized that the supercharger has merely supplemented the fixed volume pumping capacity of the cylinders with an additional fixed volume of capacity. With constant rpm and wide open throttle the supercharged engine will always draw in the same volume of atmosphere.

The power will diminish with increasing altitude as the weight of this fixed volume diminishes.

The engine designer could have obtained the same results by increasing the size or number of cylinders or, possibly, by increasing the rpm.

The essential result of supercharging, then, is that the pumping capacity of the engine has been increased and, with it, the capacity of the cylinder to produce power.

The supercharger illustrated is a single-stage, single-speed supercharger because

1. The compression is accomplished in one operation or stage
2. The impeller is driven at one fixed ratio to the crankshaft

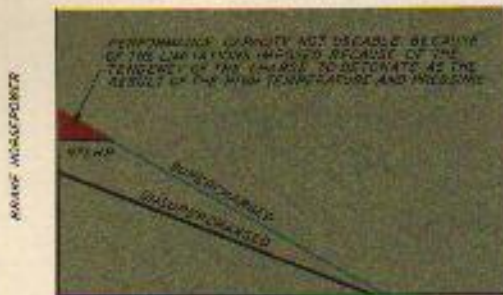

Comparison of Power

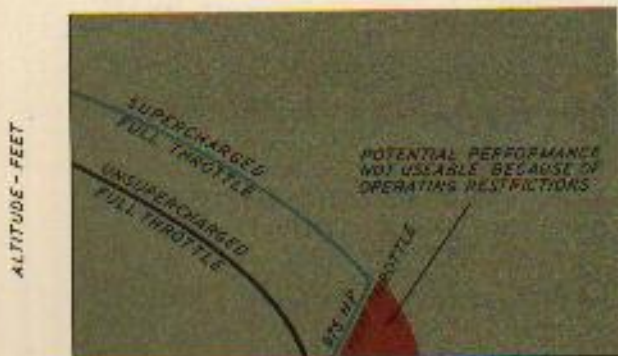

Effect on Airplane Performance



TYPICAL SYSTEM WITH 6:1 IMPELLER DRIVE RATIO
PRESSURE RATIO 1.5:1
TEMPERATURE RISE 30°C

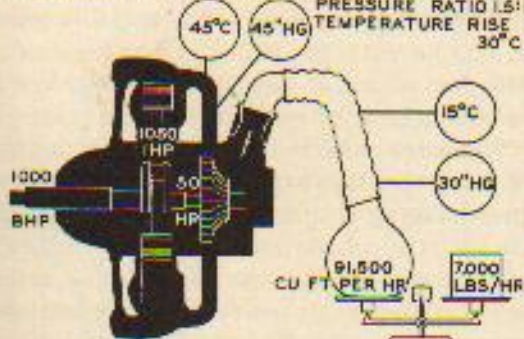

CHARACTERISTICS AT SEA LEVEL

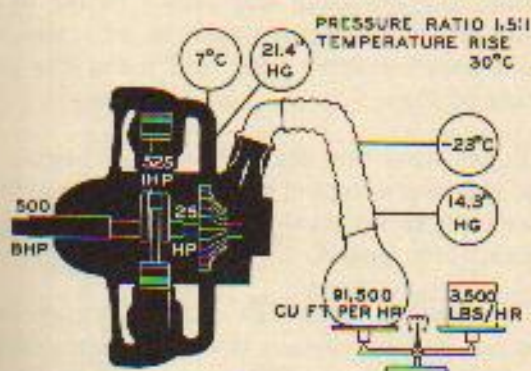

CHARACTERISTICS AT 19,000 FT. ALTITUDE

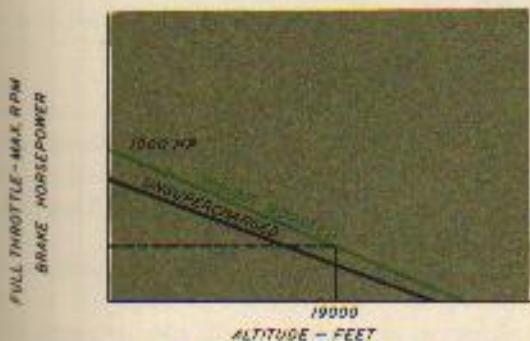

Comparison of Power



Effect on Airplane Performance

STEPS IN SINGLE-STAGE DEVELOPMENT

1. Ground Boosting

The power developed by the engine in this example is the maximum usable sea level performance which can be obtained from the basic power section. If the impeller drive ratio were lower the engine would not receive sufficient air to develop this output. If the ratio were higher, the increased charge temperature would require that the maximum pressure be limited in order to prevent detonation. The power available within this restriction would be less than the maximum power obtainable with the ground boost supercharger.

The example shown was selected to illustrate that the given ground boost supercharger provides the means of obtaining the highest possible sea level performance. Any supercharger that increases the power capacity of an engine over that obtainable without supercharging and which does not result in a restriction of operation requiring throttling at low altitude is considered a ground boost supercharger.

Engines equipped with ground boost supercharging are used on basic training and light transport aircraft. The simplicity of operation resulting from freedom of restrictions recommend it for this class of airplanes.



Effect on Installed Weight

	Unsupercharged	Ground-Boosted
Weight	900	1000
hp @ S.L. Rating	775	1000
wt/hp @ S.L.	1.16	1.00

TYPICAL SYSTEM WITH 7:1 IMPELLER DRIVE RATIO
PRESSURE RATIO 2:1
TEMPERATURE RISE 45°C

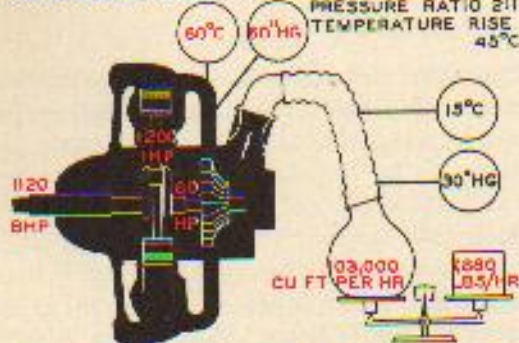

FULL THROTTLE CHARACTERISTICS
AT SEA LEVEL

PRESSURE RATIO 2:1
TEMPERATURE RISE 45°C

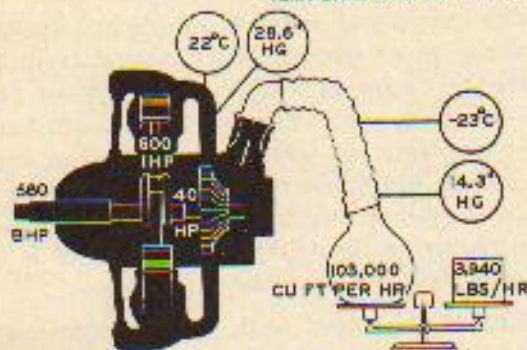

FULL THROTTLE CHARACTERISTICS
AT 19,000 FT.

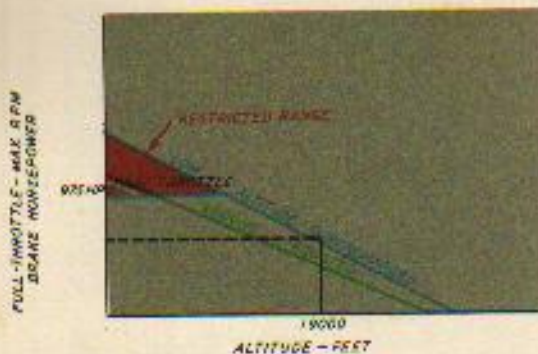

Comparison of Power

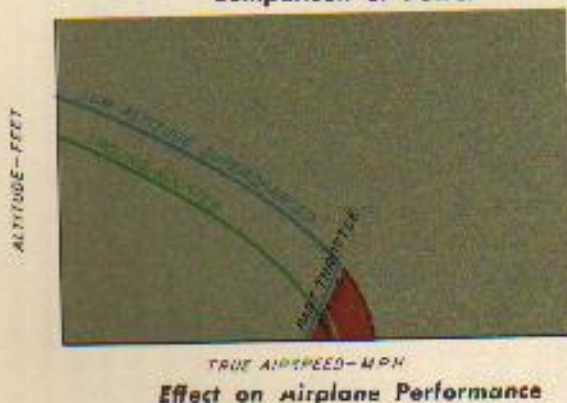

Effect on Airplane Performance

2. Low Altitude Supercharging

Stepping up the speed of the impeller provides the engine with the capacity to consume more cubic feet of air at any altitude. Near sea level the engine has the power capacity to exceed the performance that has been set up as a goal by the designer. However, because this degree of supercharging results in an increased temperature rise, the maximum usable power, or rating, must be sufficiently low so that the pressure used combined with the resulting higher charge temperature will not produce detonation.

The maximum usable power within this limitation is lower than the usable power of the ground-boosted engine provided with the optimum impeller drive ratio and using the same grade of fuel.

In selecting this degree of supercharging the designer has accepted the small loss in performance close to sea level in order to gain considerable altitude output.

The engines using this degree of supercharging can usually sustain their maximum ratings to 3000-5000 feet. This characteristic recommends their installation on transport aircraft in order to provide the required take-off performance at airports located above sea level and to obtain good cruising performance at moderate altitudes.

The usual cruising powers of these engines are sustained to 8000-14000 feet which provides a satisfactory altitude range for medium distance airline operation without cabin supercharging.

With engines equipped with a lower degree of supercharging, engine speed is the only major restriction in operation. With the introduction of altitude supercharging a new limit must be observed. This new limit is charge pressure and is indicated in the cockpit by the manifold pressure gage.

Effect on Installed Weight

	Ground Boosted	Altitude Supercharged
Weight	1000	1000
hp @ S.L. Rating	1000	975
wt./hp @ S.L.	1.00	1.03
* * * *		
hp @ 4000 ft.	875	975
wt./hp @ 4000 ft.	1.14	1.03

TYPICAL SYSTEM WITH 10:1 IMPELLER DRIVE RATIO
PRESSURE RATIO 3:1
TEMPERATURE RISE 60°C

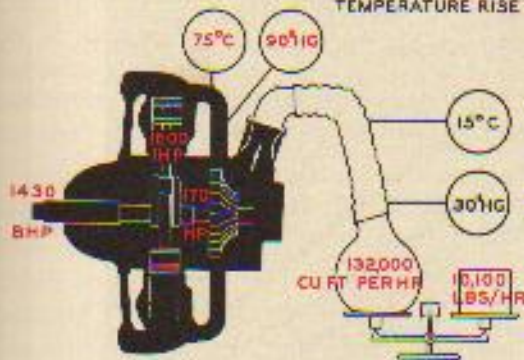

FULL THROTTLE CHARACTERISTICS AT SEA LEVEL

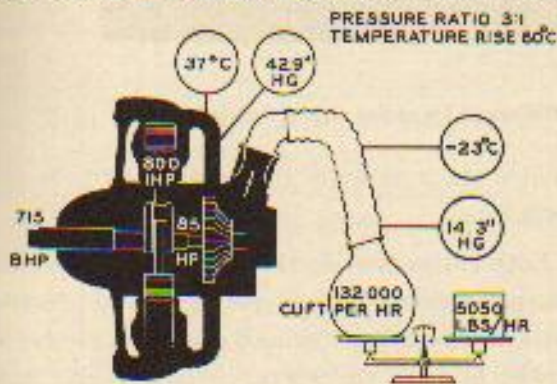

FULL THROTTLE CHARACTERISTICS AT 19000 FT.

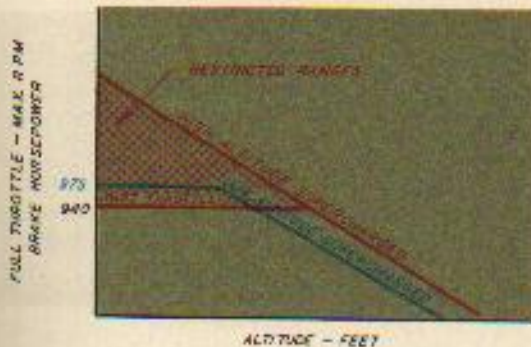

Comparison of Power



Effect on Airplane Performance

3. High Altitude Supercharging

Further increase in impeller speed still further increases the volume of atmosphere drawn into the engine and the potential power capacity has been correspondingly enlarged. However, the supercharger heat rise is now of such magnitude that the maximum power restriction is severe and the performance at low altitude is considerably reduced.

These characteristics recommend the use of engines equipped with this degree of supercharging to those airplanes requiring maximum altitude performance but which are able to take off and climb with relatively low power. Fighters are examples of this class of aircraft.

Effect on Installed Weight

	Supercharger	
	Low Altitude	High Altitude
Weight	1000	1000
hp @ S.L. Rating	975	940
wt hp @ S.L.	1.03	1.06
* * * *		
hp @ 12000 ft.	733	940
wt hp @ 12000 ft.	1.37	1.06

LIMIT OF IMPELLER SPEED

It can be seen that each step of increasing impeller drive ratio has made it necessary to impose more severe restrictions upon the brake horsepower that can be safely used at low altitude. Eventually, this restriction will become so severe that sufficient power will not be available for satisfactory performance at sea level.

Between the limits of optimum ground boost impeller speed and the limiting maximum speed, the engine designer has the choice of an infinite number of impeller drive ratios.

His selection of any one is based on the type of performance which must predominate. If maximum output is required at sea level the consequent lack of performance at altitude must be accepted. Conversely, if maximum altitude output is essential a reduction in maximum usable power is unavoidable.

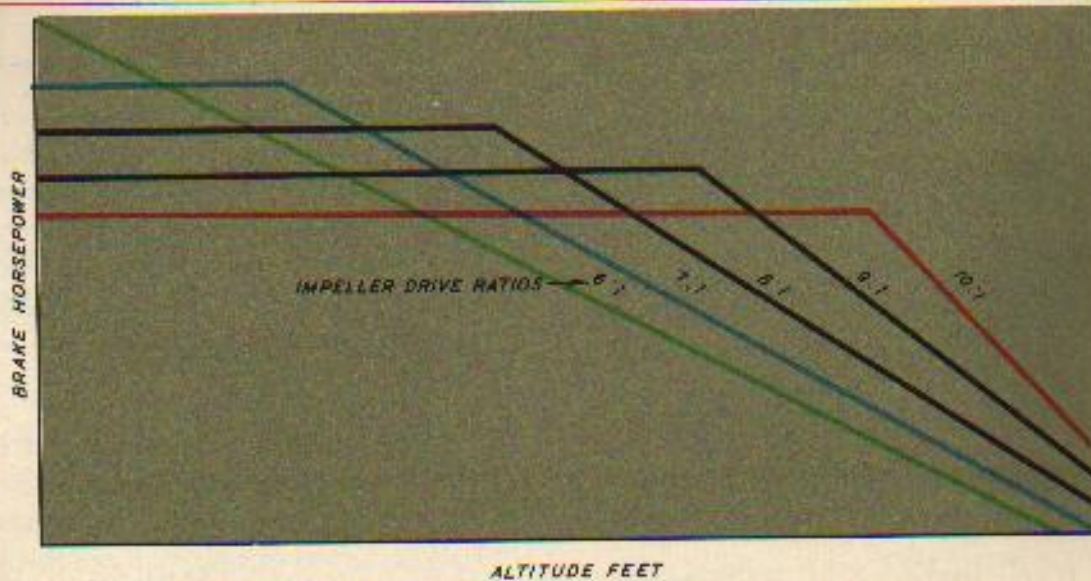

Fig. 48 — Engine Altitude Performance With Different Impeller Drive Ratios

The comparative powers obtainable through the usable range of impeller gear ratios is shown above.

ADDITIONAL SINGLE-STAGE DEVELOPMENT

The engine designer cannot reach the goal of maintaining constant power at any altitude with a single-stage supercharger using a single fixed impeller ratio. Each time he reaches for more altitude performance he loses ground near sea level. If he is to realize the possible gains of high impeller ratios without losing the advantages of the lower degree of supercharging he must devise a drive system which allows the impeller to be driven at a speed more nearly optimum to the altitude of operation. This necessity has brought about the development of the multiple and variable speed impeller drives.

THE SINGLE-STAGE, TWO-SPEED SUPERCHARGER

By providing a two-speed impeller drive and selecting ratios from Fig. 48 giving best performance at two desired altitudes, greater altitude range of airplane performance is obtained.

The low ratio is selected to give the desired output near sea level and can be any degree of supercharging from ground boost to that for low altitude. The high ratio is usually selected

to give the maximum single-stage altitude performance.

Both ratios provide the engine with the same characteristics of air volume consumed, pressure ratio, temperature rise and supercharger horsepower as with the corresponding single ratio drives.

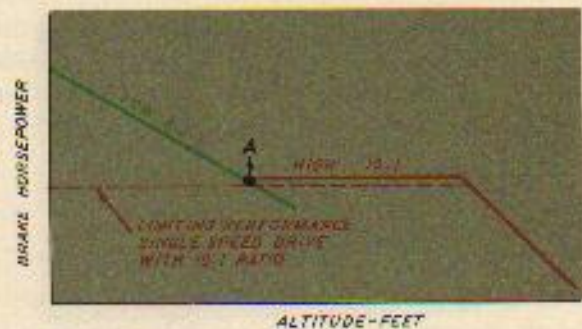

Comparison of Power

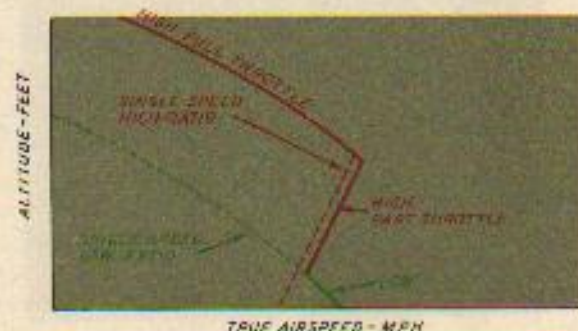

Effect on Airplane Performance

The single-stage, two-speed supercharger enables the engine to develop high power for take-off at or near sea level and, at the same time, permits the engine to maintain high airplane performance throughout the medium altitude range.

It will be noticed that in this case the maximum permissible high ratio power is greater than that of an engine having a single-speed drive of the same ratio. The gain is possible because the use of the higher ratio is reserved for altitudes where it will permit the engine to develop more power than with low ratio. For example, at 10,000 feet (Point A), the permissible engine power can be based on a charge temperature of -5 C plus the supercharger temperature rise. The same impeller speed at sea level will produce a charge temperature of 15 C plus supercharger temperature rise. The 20 C more favorable charge temperature permits a greater charge pressure and, consequently, more power.

The availability of this additional power makes it imperative that the high ratio be used only where advantageous. Premature engagement of high ratio will very probably result in detonation.

This premium of extra power when using high ratio power makes it necessary to assign two different limiting carburetor air temperatures with single-stage, two-speed engines. The higher limit is allowed with low ratio supercharging only. When high ratio is engaged, the lower limiting entrance temperature must be observed. It is only by the use of these carburetor air temperature restrictions that this additional high ratio power rating can be offered and it is essential that these considerations be understood when using carburetor preheat for ice prevention or when flying in air of extremely high temperature.

The addition of the two-speed drive involves little additional weight to the powerplant (20-40 lb) and no additional drag. Operation is somewhat more involved as ratings, limiting powers, rpm, manifold pressures and bmep are not the same for each ratio. In effect, the pilot is operating two different engines and must be aware of the differences in order to maintain proper conditions and to obtain the most efficient utilization of the powerplant.

Because of the increased versatility of performance possible with the single-stage two-speed engine it is used on a wide variety of aircraft requiring maximum performance from sea level to medium altitude.

Effect on Installed Weight

	Single-Speed Ground-Boosted Engine	Single-Speed With High Ratio Drive	Two-Speed	
			Low	High
Weight	1000	1000	1040	1040
Hp @ S.L. Rating	1000	940	1000	—
Wt/hp @ S.L.	1.00	1.06	1.04	—
* * * *				
Hp @ 12000 ft.	658	940	—	940
Wt/hp @ 12000 ft.	1.52	1.06	—	1.11

LIMITATIONS OF FIXED RATIO DRIVES

Even the multiple speed drive is a compromise. The fixed ratios are selected to give maximum performance at specific altitudes and possible performance between these points is sacrificed.

For example, the engine is provided with an 8:1 drive ratio and is rated at 750 hp at 2500 rpm. The highest altitude to which this performance can be maintained is 10,000 feet which is termed the critical altitude for this power and rpm. At this rpm and at full throttle the supercharger pressure ratio is 2.25:1.

When operating at 5000 feet the impeller speed has not changed and, hence, its pressure ratio remains the same as at 10000 feet. However, as the atmospheric pressure has increased to 24.9 in. Hg, full throttle operation would result in raising the manifold pressure to 56.0 in. Hg which, in combination with the increase in charge temperature to 55 C, would result in detonation.

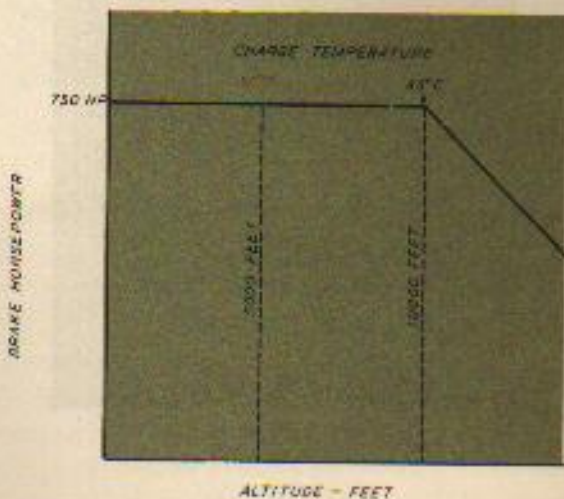

In order to restrict the engine output it is necessary to use the throttle so that the pressure at the face of the impeller does not exceed that obtained at this same point when operating at 10000 feet and with full throttle.

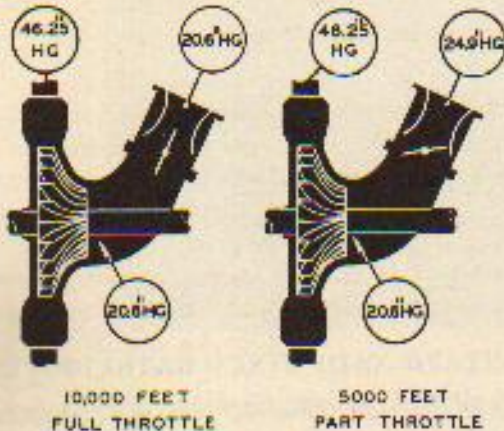

As the impeller speed remains constant the power required to drive the impeller is unchanged.

THE SINGLE-STAGE VARIABLE SPEED SUPERCHARGER

If, instead of restricting the supercharger output by means of the throttle, the necessary regulation could be obtained by means of varying the impeller drive ratio while holding full open throttle an appreciable decrease in power required to drive the impeller will result.

Taking the previous example at 5000 feet, the power delivered to the propeller can now be increased to 775 hp because the power required to

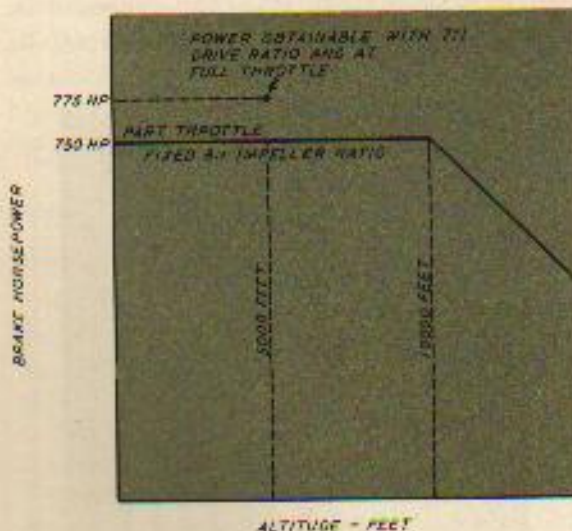

drive the impeller at 5000 feet is lower with 7:1 than with 8:1 drive ratio. This represents a direct gain in power delivered to the propeller.

By providing a variable speed impeller drive the engine designer enables the single stage engine to deliver the maximum possible performance at all altitudes and provides it with the greatest operating flexibility.

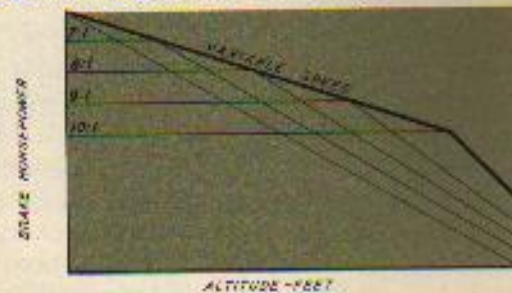

Comparison of Power

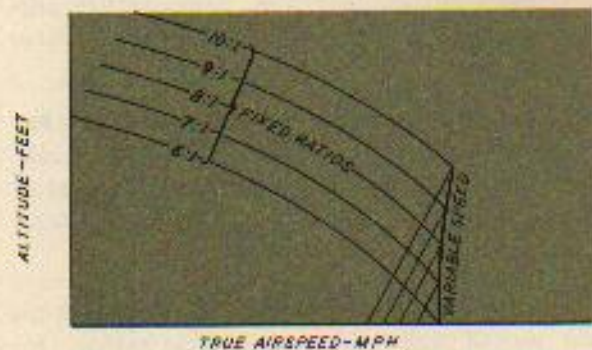

Effect on Airplane Performance

Effect on Installed Weight

	1-Stage 2-Speed	1-Stage Variable Speed
Weight	1040	1070
Hp @ S.L.	1000	1000
Wt/hp @ S.L.	1.04	1.07
Hp @ 6500 ft.	940	960
Wt/hp @ 6500 ft.	1.11	1.09
Hp @ 12000 ft.	940	940
Wt/hp @ 12000 ft.	1.11	1.14

The variable speed supercharger results in a performance which is the combination of the maximum altitude outputs obtainable with an infinite number of drive ratios varying from maximum ground boost to limiting maximum. At any impeller speed the supercharger has the same characteristics of air consumption, pressure ratio, temperature rise and supercharger horsepower as with the corresponding single ratio drive.

The variable speed drive provides the single stage engine with the maximum versatility of operation. The cost in weight is low (50-100 lb) and no increase in drag is involved. As its operation is, by necessity, automatic, control is greatly simplified.

These qualities recommend its use on all aircraft requiring maximum performance from sea level to medium altitude.



The foregoing examples trace the development of the single-stage supercharger from the variations in performance obtainable by means of different types of impeller drive. In actual practice the designer utilizes a considerable number of possible changes in the design of the impeller, induction passages and diffuser in order to obtain the most efficient combination to give the desired performance in a specified altitude range. The considerations involved in the design of a low altitude supercharger, which handles small volumes of air, differ somewhat from the design of a supercharger required to make possible maximum engine performance at 15000 feet. However, these factors do not have appreciable effect upon the method of operation and the precautions necessary for protection of the engine.

THE TWO-STAGE SUPERCHARGER

A single-stage compressor, even though all components are designed for the highest possible altitude of operation, reaches its limitations in the medium altitude range. These limitations are:

1. Size

While the examples previously shown are discussed on the basis of maintaining constant the physical dimensions of the supercharger while varying only the impeller speed, in actual practice the entire size of the compressor is increased. Entrance passages, impeller diameter and width, diffuser and collector undergo increases in size in order to handle efficiently the larger volume of air. Accordingly, a supercharger with proper sized components for high altitude will not be capable of efficient performance near sea level.

As the volume of air to be pumped becomes greater and the diameter of the impeller is increased, so does the size of the cases housing the impeller. Engine installation requirements make it essential to keep this engine section below a definite maximum diameter.

2. Temperature rise

As the pressure ratio increases, the resulting temperature rise becomes excessive and imposes limitations on usable brake horsepower that are impractical.

These limitations are avoided by dividing the supercharger into two separate parts and accomplishing the compression in two steps. This system is called the two-stage system as the compression is accomplished in two steps or stages. The stages are connected in series and the limitations of the single-stage system are avoided as follows:

1. Size

Two stages of compression are provided. The main stage is identical to the supercharger of the single-stage engine and, on the system used by Pratt and Whitney Aircraft, it is possible to operate near sea level using the main stage only. By this means, the size of the main stage components is optimum for low altitude performance. The auxiliary stage is designed to handle efficiently the larger volume of air at high

altitude. It delivers the air to the main stage at approximately sea level pressure so that, at all times, the main stage is functioning near its point of best performance.

By using two small impellers having the same airflow capacity as one of large size, the diameter of the supercharger section is held within reasonable installation limitations.

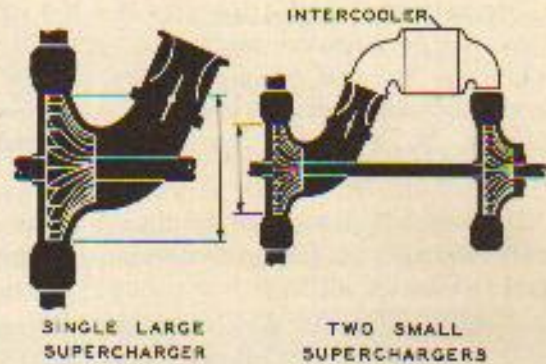

BOTH PUMP THE SAME QUANTITY OF AIR

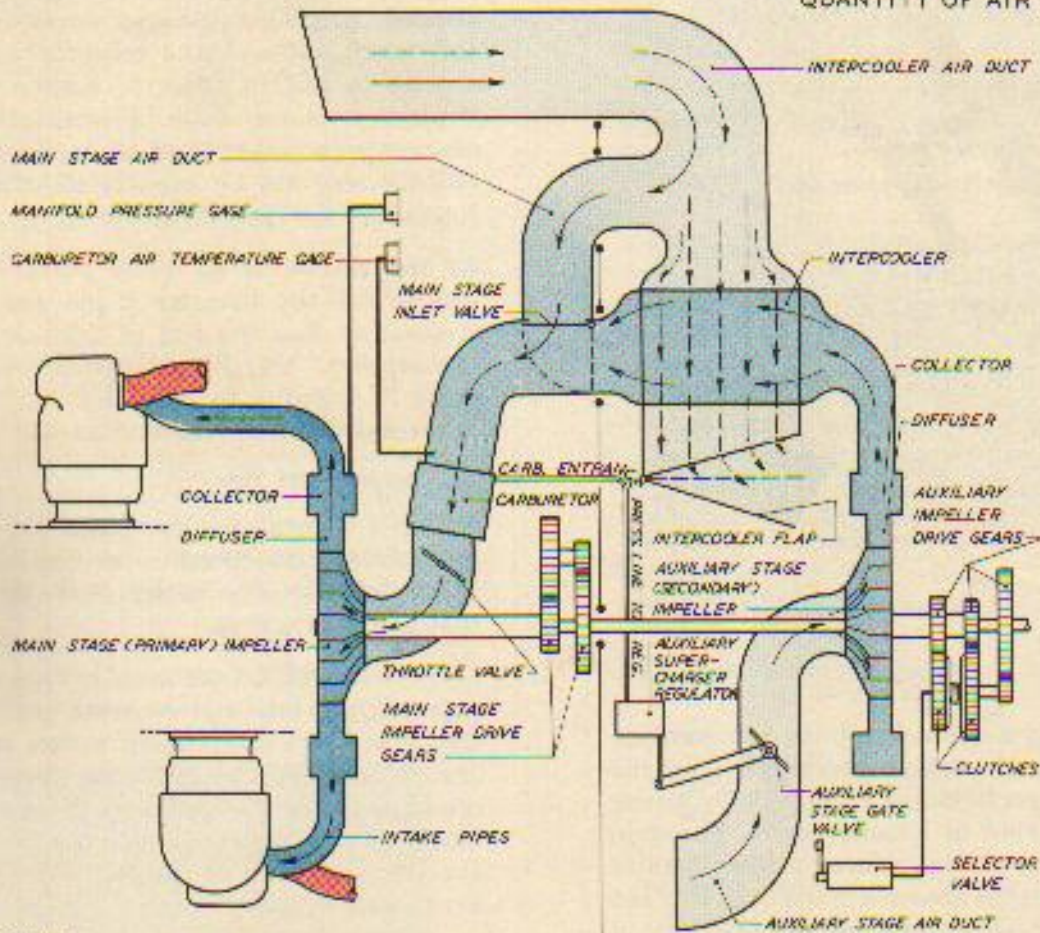

Main Stage
Same as single-stage, single-speed. This stage is always engaged. The impeller drive ratio is selected to give the desired performance near sea level without the use of the auxiliary stage. For take-off, maximum performance near sea level, and cruising economy, operation is with main stage only.

Auxiliary Stage
Engaged when performance requirements cannot be met by sole use of the main stage.

Fig. 49 — The Two-Stage System with Gear Driven, Two-Speed Auxiliary Stage

2. Control of temperature rise

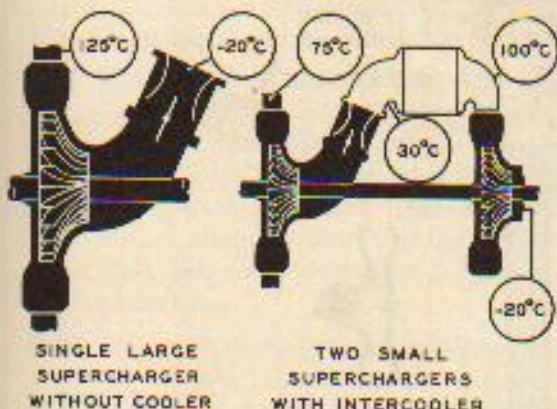

By cooling the charge between the steps of compression the temperature at the intake port, is held within safe limits. This between-stage or intercooling is utilized on all Pratt & Whitney Aircraft two-stage systems but it is not necessarily used on all two-stage engines.

EFFECT OF TWO-STAGE SYSTEM ON AIRPLANE

The addition of the auxiliary stage to the single-stage engine involves penalties in the form of increased engine weight and size, and additional weight, size and drag to the airplane. In addition to the added engine weight, the supercharger must be charged with the weight of the intercoolers, ducts and extra controls. The in-

creased airplane size, plus the drag involved in passing cooling air through the intercoolers, detracts from the aerodynamic cleanliness of the installation.

Taking two similar airplanes, one using single-speed supercharging, the other two-stage, and both designed to obtain the best utilization of their powerplants, the airplane with the single-stage will be lighter and cleaner and will have

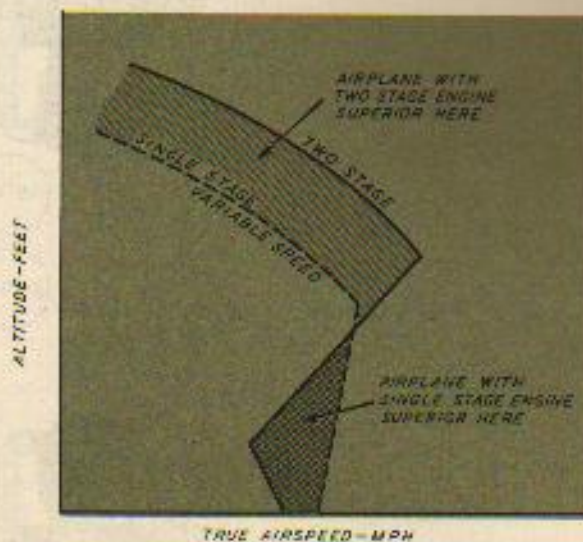

superior performance in the altitude range where its engine can maintain equal power.



TYPICAL SYSTEM WITH THE FOLLOWING IMPELLER DRIVE RATIOS
 MAIN STAGE (NEUTRAL) 6:1
 AUXILIARY STAGE LOW 6.5:1
 AUXILIARY STAGE HIGH 8:1

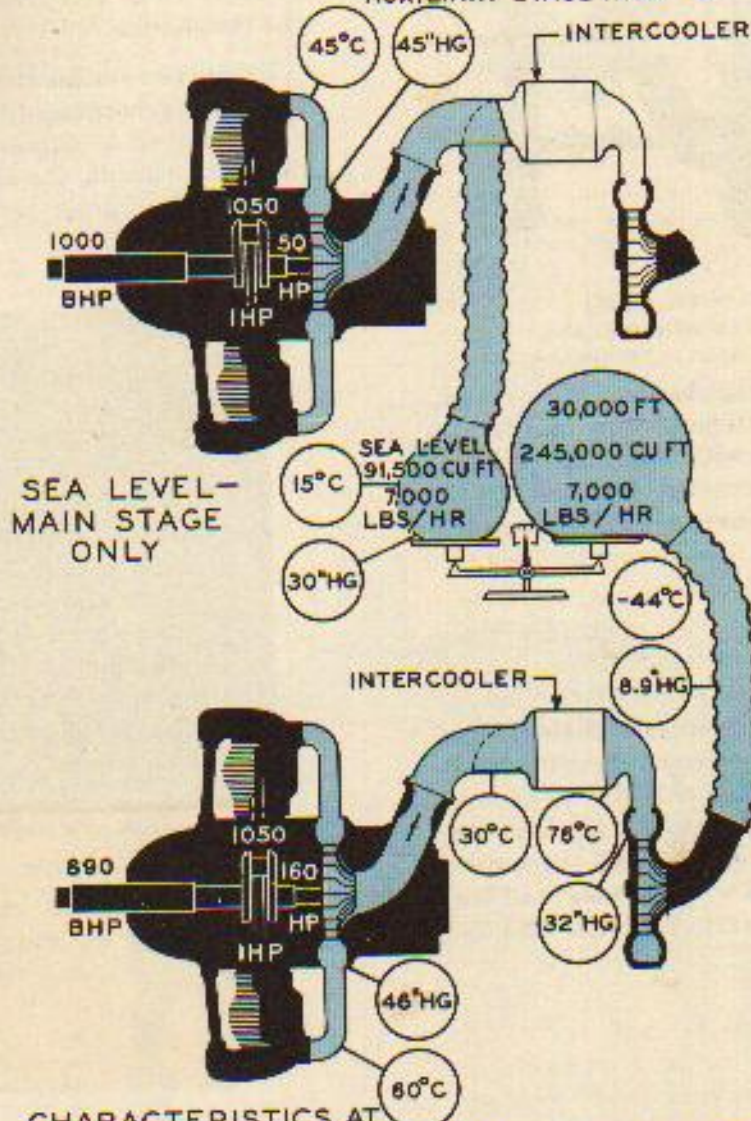

A Typical Two Stage System

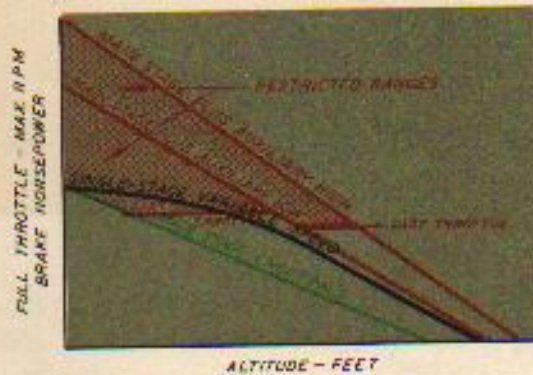

Comparison of Power



Effect on Airplane Performance

TWO STAGE SYSTEMS

1. Gear-Driven Auxiliary Stage
a. Fixed Ratio Drive

The use of the two-stage, two-speed supercharger allows the engine to deliver its maximum output at or near sea level and at the same time makes it possible to maintain high output to higher altitudes than could be obtained with the most advanced single-stage system.

These characteristics recommend the use of this type of compressor on installations requiring a uniform high performance through a wide range of altitude without unduly penalizing the compactness of the installation. Many of the most effective fighters used in World War II utilized engines equipped with this type of supercharger.

Efficient operation of the two-stage, two-speed supercharger places greater demands upon the pilot than single-stage systems. In effect, three different engines are selectively available and in each stage, different limitations of power, bmep and carburetor air temperature are called for. Efficiency is largely determined by the knowledge of the correct altitude range in which to use each degree of supercharging so that the maximum potential performance or economy can be realized.

For example, if the shift from "neutral" to "low" is made prematurely, considerable power is lost as "neutral" will furnish more power to the propeller as long as it can maintain the manifold pressure to which "low" is limited.

If the shift is delayed by allowing the full throttle manifold pressure to fall off below the proper shift value while in "neutral," possible performance is again lost by not taking advantage at the right time of the increased permissible power capacity of "low." The same considerations apply when shifting from "low" to "high." While rough "rule of thumb" procedures for shifting have sufficed to obtain a reasonably effective use of this equipment, maxi-

imum efficiency can only be obtained by a thorough knowledge of the principles applying to its operation.

Effect on Installed Weight

	1-Stage, Variable	2-Stage, 2-Speed
Wt. Engine	1070	1320
Extra Items, Intercoolers, Ducts, etc.		250
Total	1070	1570
Power @ S.L. Rating	1000	1000
Wt/hp @ S.L.	1.07	1.57
Power @ 30000 Ft.	483	890
Wt/hp @ 30000	2.22	1.76

b. Variable Speed Drive

The two-stage gear-driven supercharger can be provided with a variable speed drive similar to that used on the single-stage engine. It is possible to use this type of drive on both main and auxiliary stages or to drive the main stage impeller at a fixed ratio reserving the variable speed operation for the auxiliary supercharger. The advantages realized are the same as with the single-stage supercharger.

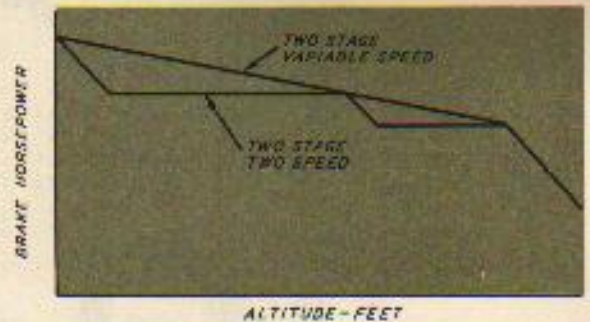

Comparison of Power

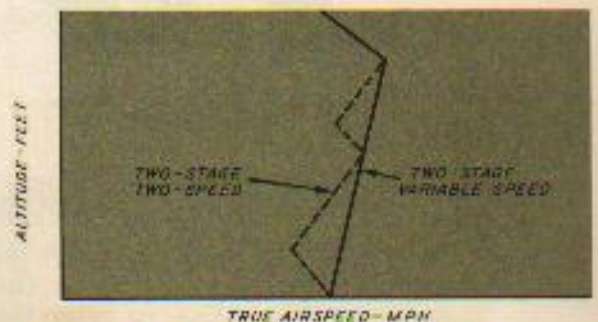

Effect on Airplane Performance

While the mechanism required to drive and control the two-stage, variable-speed supercharger represents in-

creased complications, it results in relieving the pilot of considerable responsibilities for decisions regarding the use of the various compressor stages. Operation is entirely automatic and calls for little more cockpit attention than would be required by a single-stage engine.

c. Other Arrangements of Gear-Driven Two-Stage Superchargers

The two-stage arrangement shown in Fig. 49 is the one that has been used successfully on Pratt and Whitney Aircraft engines. Other engine manufacturers have used other arrangements successfully. The selection of the system depends upon the engine configuration and the installation problems involved.

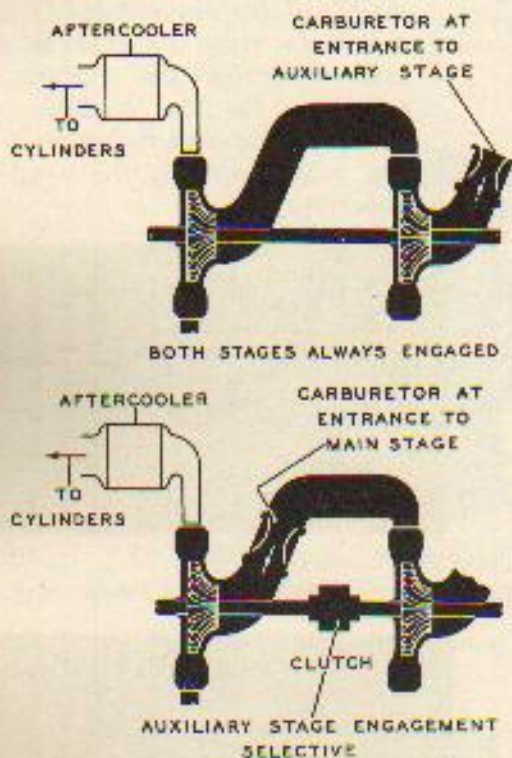

The above combinations can be rearranged almost indefinitely with the carburetor before the auxiliary stage, interstage or after the main stage. The cooler can be interstage or after the main stage. Sometimes it is omitted. The configuration of the radial engine makes it most logical for it to use the arrangement originally shown.

2. The Exhaust Turbine-Driven Auxiliary Stage

The exhaust turbine-driven supercharger is basically the same as the auxiliary stage of the gear-driven two-stage supercharger. The impeller, diffuser and collector are designed to accomplish the same function as a gear-driven auxiliary stage. The essential difference is that with the turbo supercharger the impeller is driven by a turbine utilizing the energy available in the exhaust gases. The relation between the auxiliary and main stage, intercoolers and carburetors are the same in both systems. A turbine-driven supercharger is, then, a variable speed auxiliary stage compressor and its use allows the maintenance of sea level power to high altitude within the limits of allowable turbine speed and over-all temperature rise.

SUMMARY

Supercharging offers the means of obtaining wide varieties of application of a given basic engine power section to different altitude requirements. The engine designer, utilizing the same cylinders, pistons, main cases, etc., is able, by the addition of the proper degree of supercharging, to make the same basic engine fit the peculiar requirements of several types of aircraft. To accomplish the same results by means of unsupercharged engines, the engine designer would have to provide a completely different engine for each altitude need. The advantages of manufacturing economy and in supply and maintenance are obvious.

Each additional increase, in the degree of supercharging, enlarges the restrictions necessary in order to insure safe engine operation. It is essential that the operator understand the necessity for these restrictions and base his operating procedures on a well-founded knowledge of the effect of the supercharger used on engine operating efficiency and safety.

For the users of engines equipped with one of the several superchargers, Pratt & Whitney Aircraft has publications available which discuss in detail the operating problems peculiar to specific supercharger models. These instructions are supplementary to this general instruction and are available to those operators having definite need for this information.

APPENDIX

The following information was originally issued as Engine Operation Information Letters which supplemented *The Manual of Engine Operation*. The subjects covered are of general interest to engine operators and, therefore, are included in this reprinted copy.

Carburetor Air Temperature Measurement On Single Row Engines	A3
Attention: Operators With Float Type Carburetors	A3
Fuel Pressure Limits With Pressure Injection Carburetors	A4
Magneto Check On Wasp (R-1340) Engines	A5
Twin Wasp "C" (R-1830) and "D" (R-2000) Cylinder Head Temperature Limits	A5
Consideration Of Engine Temperatures During Practice Feathering And Unfeathering	A6
Reverse Pitch Propeller Operation	A7
Procedure To Be Followed In The Event Of Runaway Propeller	A8
Take-off And Carburetor Air Temperature Limitations On The Use Of High Impeller Ratio	A9
Magneto Checks During Flight	A10
Pre-flight Power Checking	A10
Use Of Full Take-off Power	A12
Control Of Power	A13
Torque Pressure Drop Method Of Setting Cruise Mixture	A14
Engine Overspeeding	A25
Checking Propeller After Reverse Pitch Operation	A26
Use of Fuel Boost Pumps	A27
Power Loss In Double Wasp CA (R-2800) Engines Under Moist Air Conditions	A28
The Effect Of Mixture Strength On Cylinder Head Temperature And Break Horsepower	A30
Idle Mixture Setting	A33
Manifold Pressure vs Rpm At Part Throttle	A33
Extinguishing Engine Blower Fires During Starting	A37
Prestart Engine Procedure	A38
Minimum Manifold Pressure	A40
Emergency Use Of Prime To Restore Power Under Icing Conditions	A41
Water Injection For Reciprocating Engines	A42