

Nomenclature

x, y	longitudinal, spanwise positions	S_h	horizontal tail area
S	reference area (wing area)	S_v	vertical tail area
b	wing span	ℓ_h	horizontal tail moment arm
c	average wing chord ($= S/b$)	ℓ_v	vertical tail moment arm
AR	wing aspect ratio	AR_h	horizontal tail aspect ratio
C_L	lift coefficient	V_h	horizontal tail volume coefficient
Υ	wing dihedral angle	V_v	vertical tail volume coefficient
β	sideslip angle	B	spiral stability parameter
ϕ	bank angle	α	angle of attack
R	turn radius	V	velocity

Role of Simple Design Rules

Aircraft must have a certain amount of inherent stability and controllability to be flyable. It is therefore important to consider these characteristics when designing a new aircraft. Accurate evaluation of the stability characteristics of any given aircraft is a fairly complicated process, and is not well suited for preliminary or intermediate design. Fortunately, we have alternative criteria which give reasonable estimates and are vastly simpler to apply.

The criteria involve basic dimensions, shown in Figure 1. Longitudinal x locations are typically

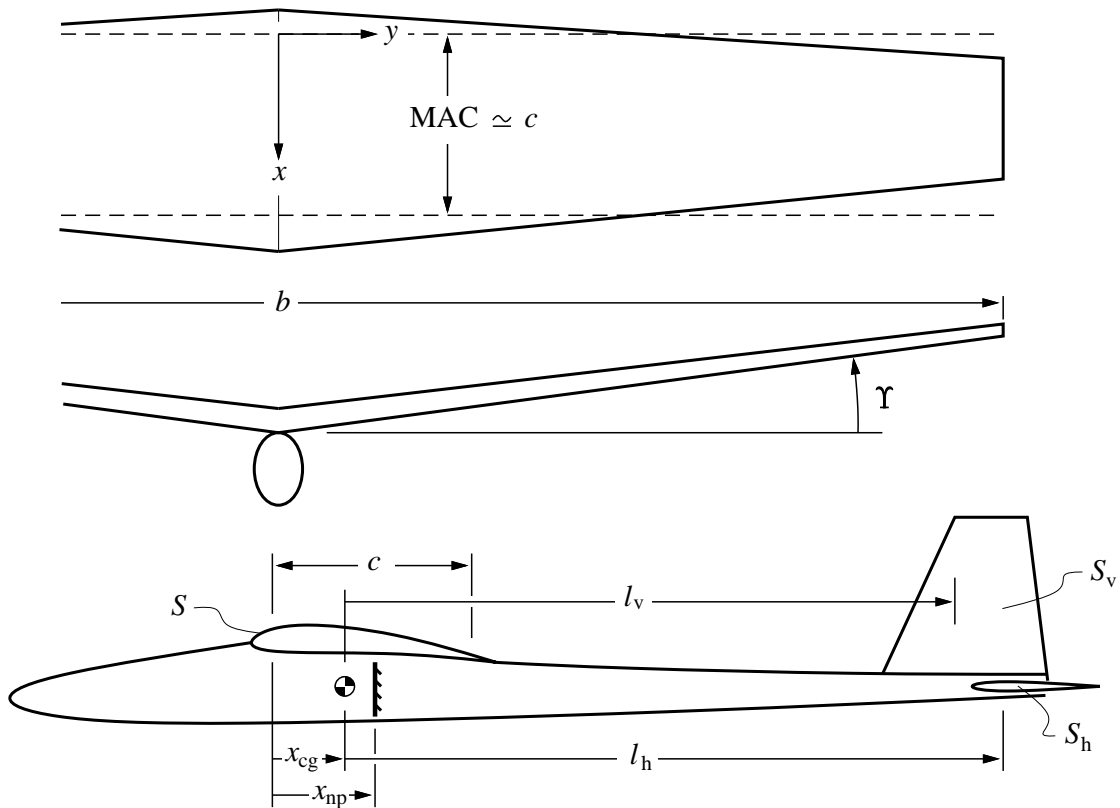

Figure 1: Lengths, areas, and angles used in simple stability criteria.

measured relative to the leading edge of the wing's *Mean Aerodynamic Chord*, or MAC, which is the root-mean-square average chord. For most wings this is very nearly equal to the simple-average chord c .

The l_h and l_v tail moment arms are the distances between the Center of Gravity (CG) and the average quarter-chord locations of the horizontal and vertical tail surfaces. The criteria which will use these dimensions are estimates, so it's acceptable to estimate the CG position and to "eyeball" the tail average quarter-chord locations when measuring l_h and l_v .

Center of Gravity Position

An aircraft's horizontal tail size and position, and the CG position are the dominant factors controlling the aircraft's *pitch stability*, which is the tendency to automatically maintain an angle of attack and airspeed. The basic effects of moving the CG position are:

- Decrease x_{cg}/c (move CG fwd.): increased stability; more resistance to α and V changes.
- Increase x_{cg}/c (move CG back): decreased stability; less resistance to α and V changes.

There is one particular CG position which gives *neutral* stability, which is called the *Neutral Point* (NP). This is shown as x_{np} in Figure 1. The degree of pitch stability or instability is traditionally specified by the *Stability Margin*.

$$\text{S.M.} = \frac{x_{np} - x_{cg}}{c} \quad (1)$$

Figure 2 illustrates the natural behaviors of an airplane after a pitch disturbance, for different values of S.M. The unstable behavior occurs when S.M. is negative, i.e. when the CG is behind the NP. Because pitch instability makes the aircraft very difficult or impossible to control, the NP position is considered to be a practical *aft CG limit*.

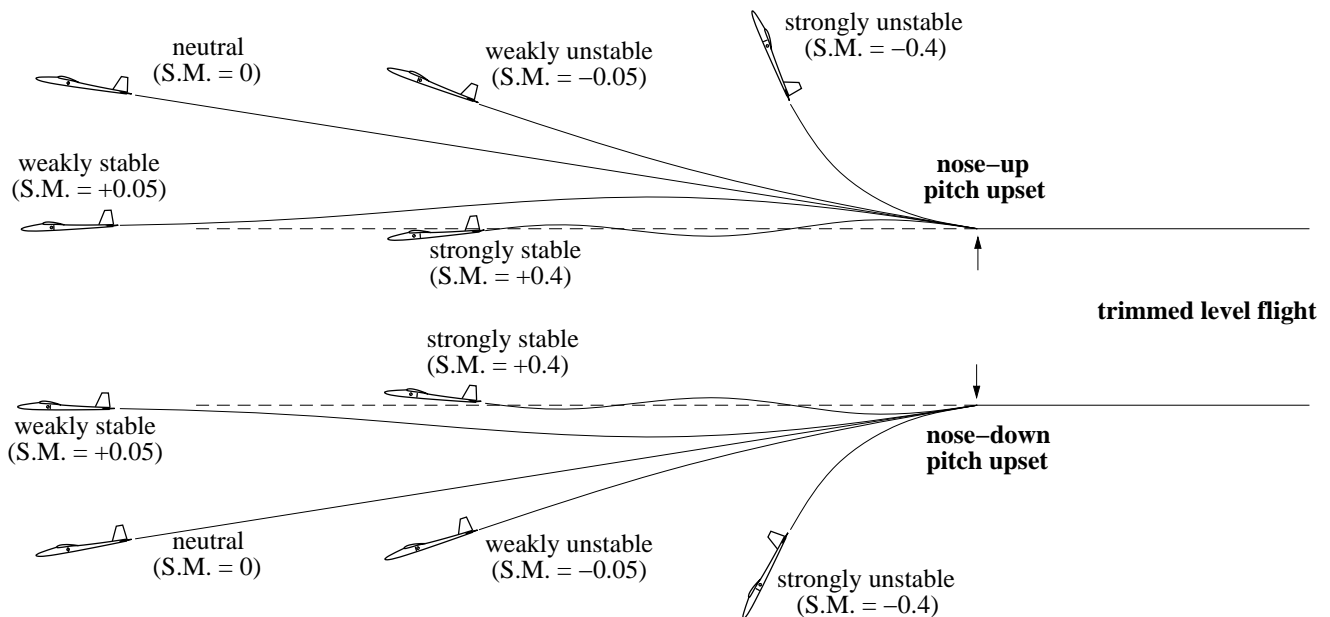

Figure 2: Natural aircraft responses to a pitch disturbance, for different amounts of pitch stability.

Making the S.M. strongly positive by moving the CG far forward will give plenty of pitch stability and a strong resistance to pitch upsets, but it also has undesirable side effects. One large drawback

of a large S.M. is that it causes large (and annoying) pitch trim changes with changing airspeed. Figure 3 shows the flight paths of airplanes with different nonnegative S.M., immediately after an airspeed increase caused by a power increase. The straight-ahead acceleration of the weakly stable or neutral airplane is more desirable for the pilot.

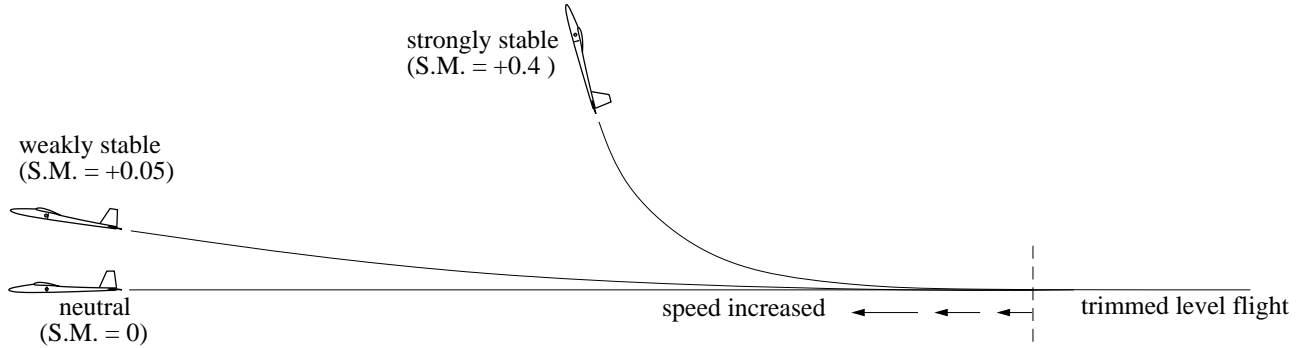

Figure 3: Pitch-up behavior from an airspeed increase, for large and small Static Margin.

More specifically, the strongly stable airplane shown in Figure 3 requires a relatively large elevator angle change commanded by the pilot to restore it to level flight. Figure 4 compares the situation for the strongly and weakly stable airplanes. In effect, a large positive S.M. degrades the *pitch trim authority* of the elevator, since large trim deflections are needed to maintain level flight in response to airspeed changes.

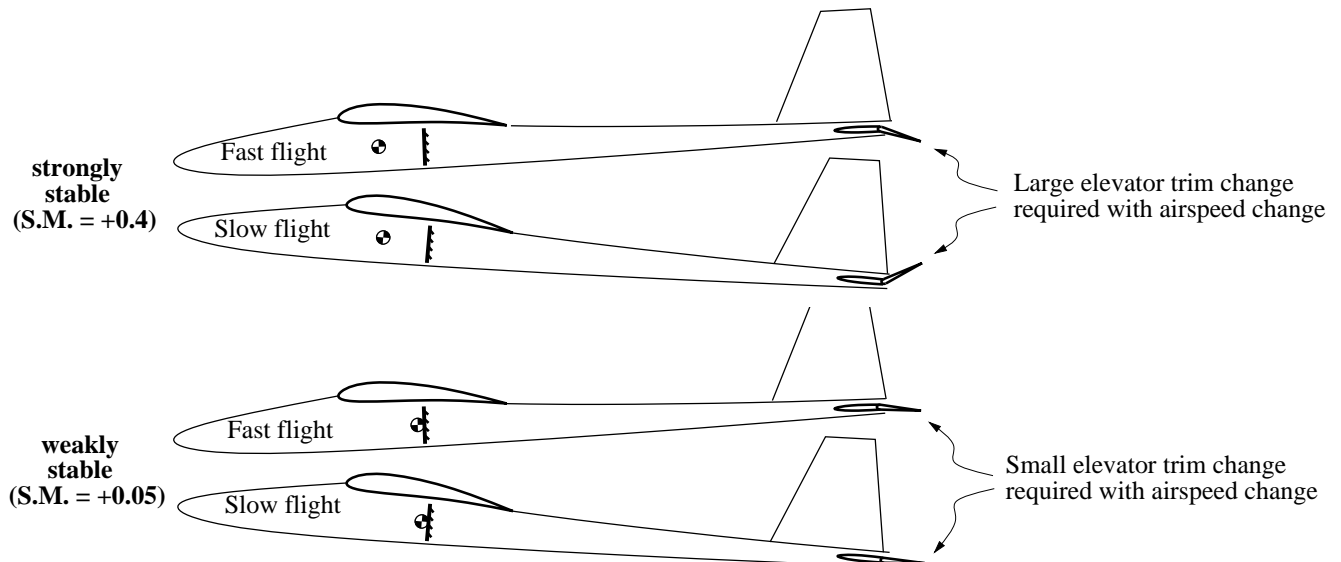

Figure 4: Elevator trim adjustment with changing airspeed, for large and small Static Margin.

This situation illustrates the benefit of reducing the S.M., by moving the CG closer to the NP. However, if the CG is moved behind the NP, the airplane will now have a negative S.M., and be unstable in pitch to some degree, with the results illustrated in Figure 2. This makes it difficult or even impossible to fly. In general, the small positive S.M. suggested by rule (2) is the ideal situation.

$$S.M. \equiv \frac{x_{np} - x_{cg}}{c} = +0.05 \dots +0.15 \quad (2)$$

Horizontal Tail Sizing Criteria

The Neutral Point location x_{np} is primarily controlled by size of the horizontal tail and its moment arm from the CG. A measure of this tail effectiveness is the *horizontal tail volume coefficient*:

$$V_h \equiv \frac{S_h \ell_h}{S c} \quad (3)$$

A well-behaved aircraft typically has a V_h which falls in the following range:

$$\boxed{V_h = 0.30 \dots 0.60} \quad (4)$$

If V_h is too small, the aircraft's pitch behavior will be very sensitive to the CG location. It will also show poor tendency to resist gusts or other upsets, and generally "wander" in pitch attitude, making precise pitch control difficult.

The V_h also directly affects the NP location x_{np} , which can be estimated by the following expression.

$$\frac{x_{np}}{c} \simeq \frac{1}{4} + \frac{1 + 2/AR}{1 + 2/AR_h} \left(1 - \frac{4}{AR + 2} \right) V_h \quad (5)$$

The derivation of this formula is beyond scope here, but it is straightforward to evaluate for any aircraft configuration. With x_{np} estimated via (5), the CG location x_{cg} can be positioned at a good and safe location using rule (2).

Vertical Tail Sizing Criteria

The primary role of the vertical tail is to provide *yaw damping*, which is the tendency of yaw oscillations of the aircraft to subside. The vertical tail also provides *yaw stability*, although this will be almost certainly ensured if the yaw damping is sufficient. One measure of the vertical tail's effectiveness is the *vertical tail volume coefficient*:

$$V_v \equiv \frac{S_v \ell_v}{S b} \quad (6)$$

Most well-behaved aircraft typically have a V_v which falls in the following range:

$$\boxed{V_v = 0.02 \dots 0.05} \quad (7)$$

If V_v is too small, the aircraft will tend to oscillate or "wallow" in yaw as the pilot gives rudder or aileron inputs. This oscillation, shown in Figure 5, is called Dutch Roll, and makes precise directional control difficult. A V_v which is too small will also give poor rudder roll authority in an aircraft which uses only the rudder to turn.

Picking suitable V_h and V_v values for any new aircraft design is partly a matter of experience. One common approach is to simply duplicate the V_h and V_v values of an existing aircraft which is known to have good stability and control characteristics.

Dihedral Sizing Criteria – Spiral Stability

The *dihedral angle* of the wing, denoted by Υ in Figure 1, provides some degree of natural spiral stability. A spirally-unstable aircraft tends to constantly increase its bank angle at some rate, and therefore requires constant attention by the pilot. Conversely, a spirally-stable aircraft will tend to

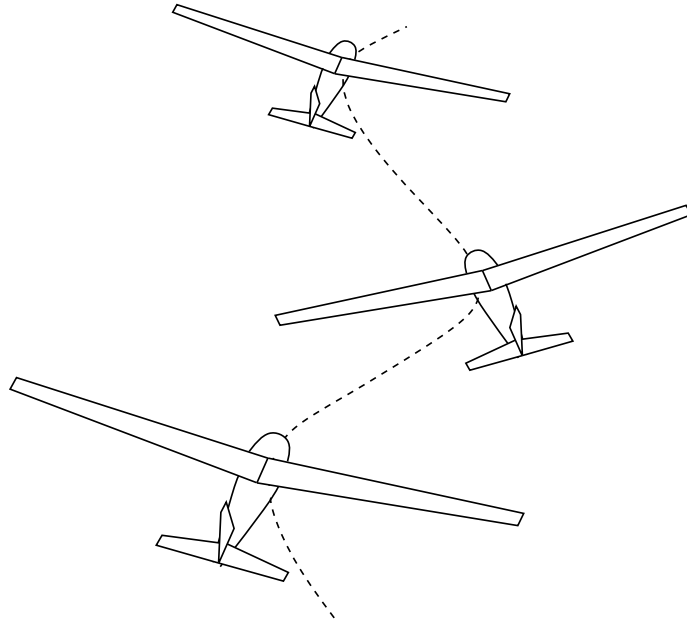

Figure 5: Dutch roll oscillation tendency from insufficient vertical tail volume.

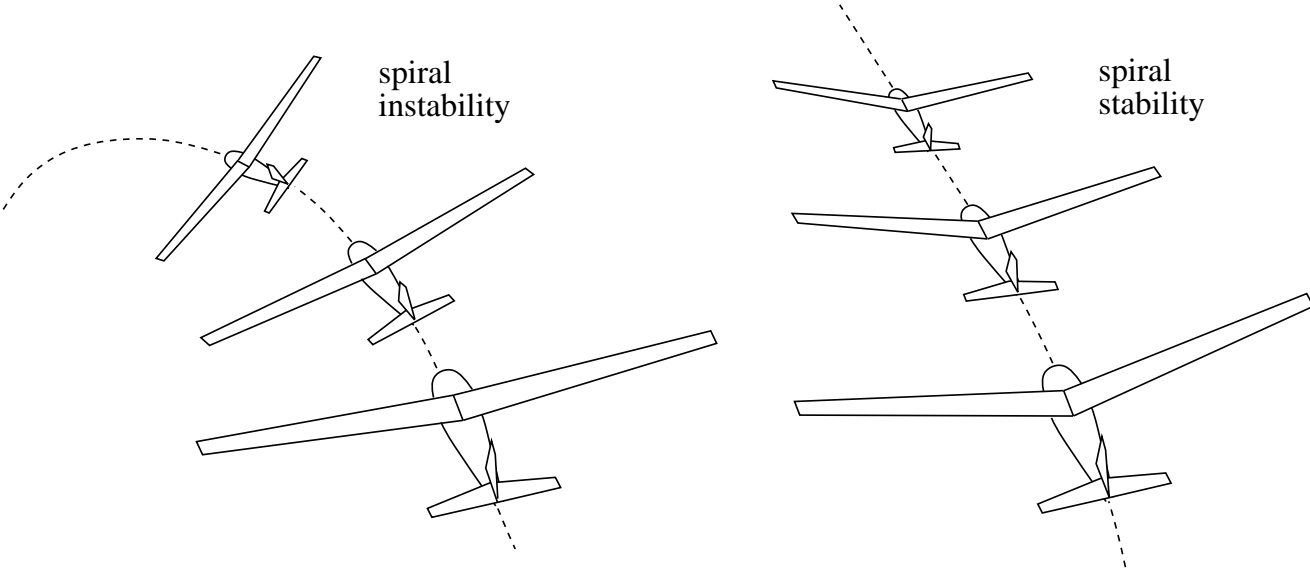

Figure 6: Spiral instability and spiral stability, depending on amount of dihedral.

roll upright with no control input from the pilot, and thus make the aircraft easier to fly. Figure 6 compares the two types of behavior.

Whether an aircraft is spirally stable or unstable can be determined via the spiral parameter B (named after its originator Blaine Rawdon, from Douglas Aircraft):

$$B \equiv \frac{\ell_v}{b} \frac{\Upsilon}{C_L} \quad (\Upsilon \text{ in degrees}) \tag{8}$$

$B > 5$, spirally stable $B = 5$, spirally neutral $B < 5$, spirally unstable	$\tag{9}$
--	-----------

The main parameter which is used to adjust B in the design phase is the dihedral angle Υ .

Spiral stability is not a hard requirement, and most aircraft are in fact spirally unstable. Level flight is then ensured either by the pilot, or by a wing-levelling autopilot, provided the instability is slow enough. RC aircraft which can fly stably hands-off must be spirally stable, although a small amount of instability ($B = 3 \dots 4$, say) does not cause major difficulties for an experienced pilot.

Dihedral Sizing – Roll Control

On rudder/elevator aircraft, the rudder acts to generate a *sideslip angle* β , which then combines with dihedral to generate a roll moment and thus provide roll control. The effect is shown in Figure 7. A criterion for adequate roll authority is obtained by the product of V_v and B :

$$\boxed{V_v B = 0.10 \dots 0.20} \quad (10)$$

The 0.10 value will likely give marginal roll control, while 0.20 will give very effective control.

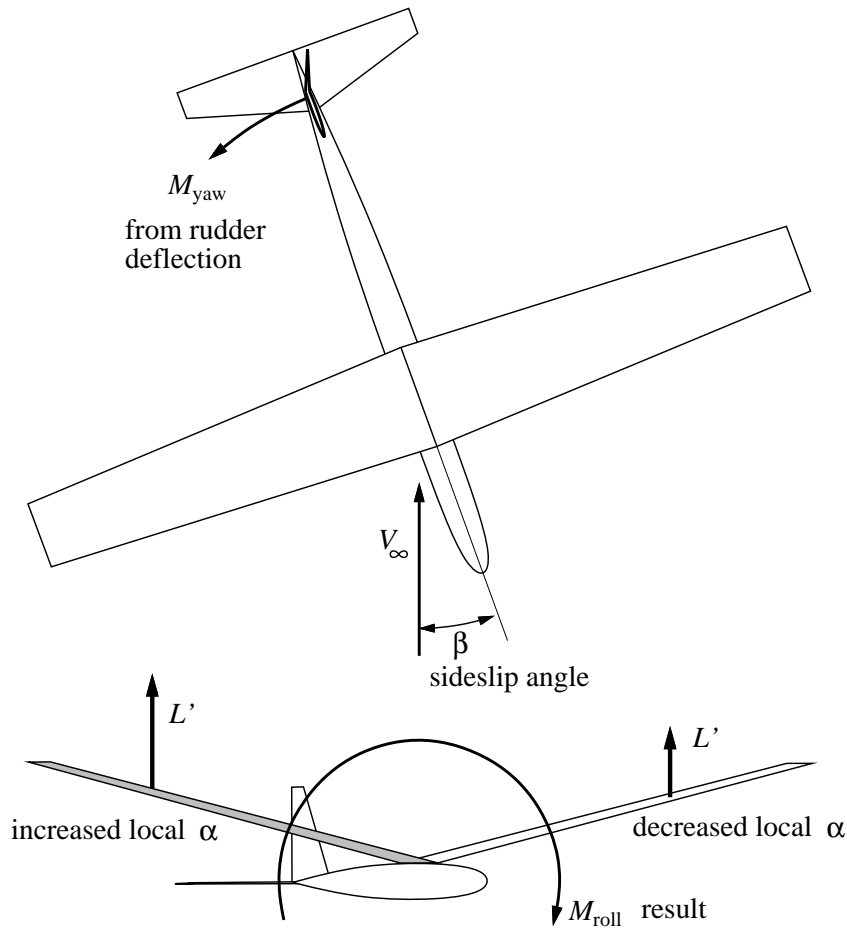

Figure 7: Rudder causes sideslip angle β , which acts with dihedral to create roll moment.

Dihedral Sizing Criteria – Steady Sideslip in Turns

An aircraft in a steady level turn must have a bank angle ϕ , equal to

$$\phi = \arctan \frac{V^2}{gR}$$

where R is the turn radius. The turning aircraft also sees a linear relative velocity variation $u(y) = V(1 - y/R)$ across the span, as shown in Figure 8. This increases the lift on the outboard tip relative to the inboard tip, and causes a roll moment tending to increase the bank angle and thus steepen the turn.

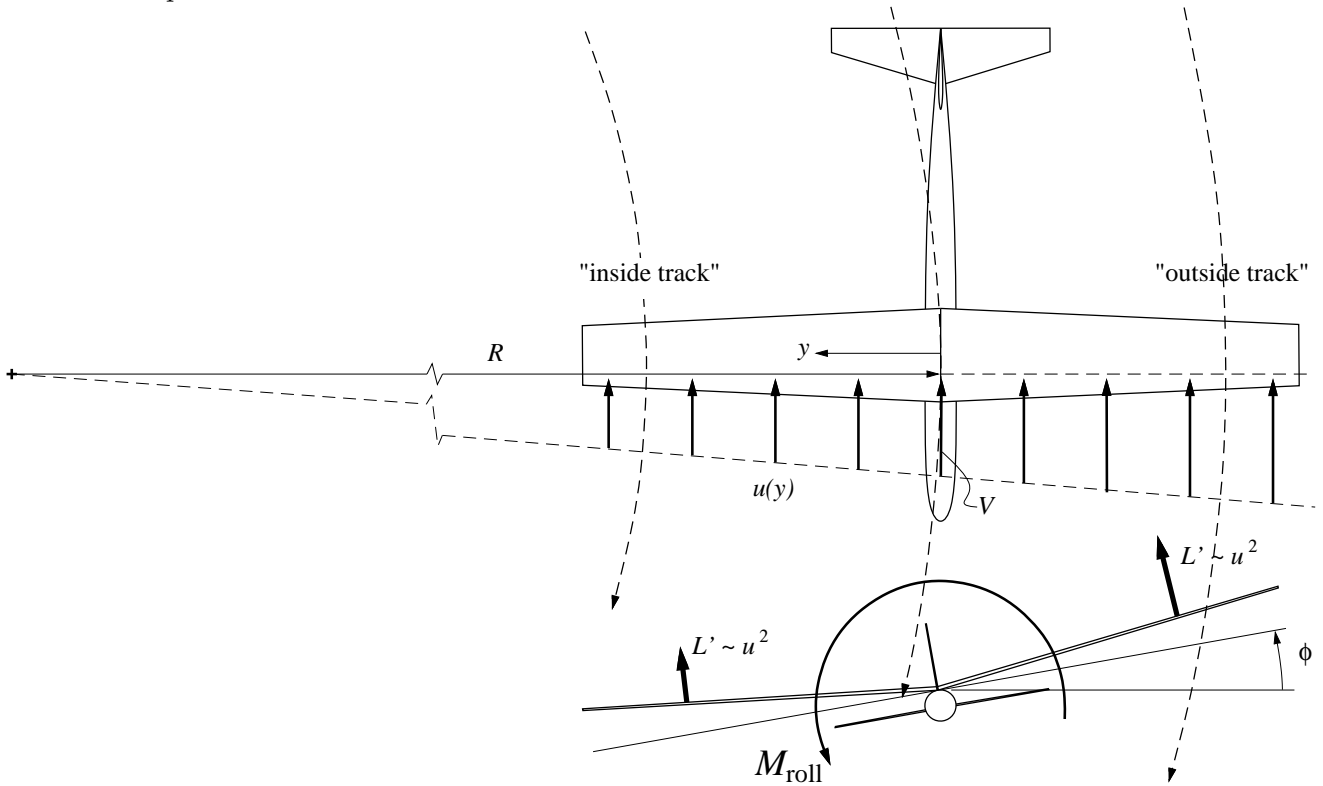

Figure 8: Curved flight path in a turn causes a relative velocity $u(y)$ variation across the span, which produces an inward rolling moment from the resulting lift imbalance.

On most airplanes, the inward rolling moment is normally cancelled by a very slight outward aileron deflection, as shown in Figure 9.

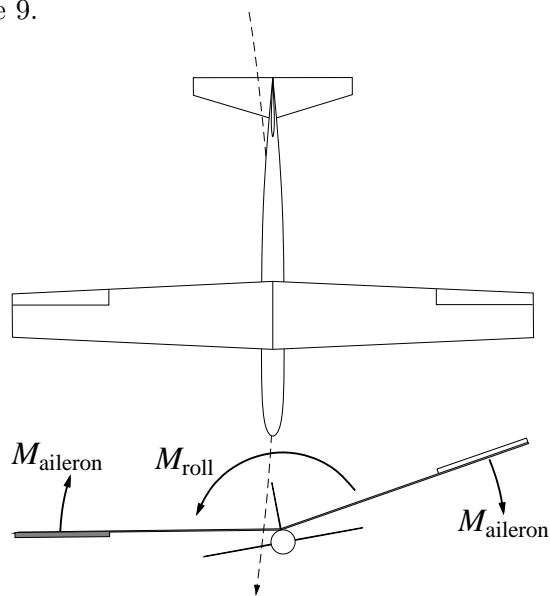

Figure 9: Outward roll moment from ailerons cancels inward roll moment from curved flight path.

On aircraft without ailerons, this inward rolling moment can only be neutralized by a steady sideslip angle with the nose pointing outside of the flight circle, as shown in Figure 10. The sideslip angle

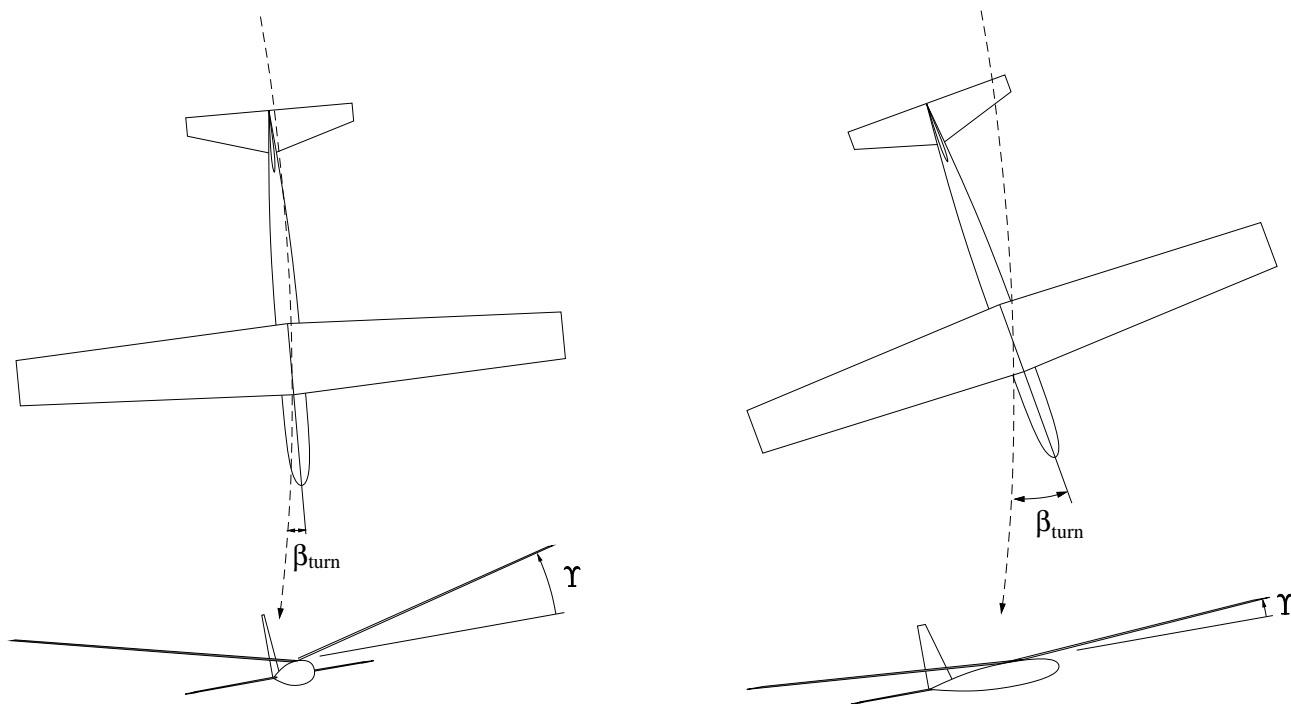

Figure 10: Outward roll moment from sideslip angle β_{turn} cancels inward roll moment from curved flight path. Smaller dihedral Υ requires larger β_{turn} .

necessary to cancel the roll moment effect of the $u(y)$ variation is approximately

$$\beta_{\text{turn}} \simeq \frac{1}{\Upsilon} \frac{C_L}{dC_L/d\alpha} \frac{b}{2R} \cos \phi \quad (\beta, \Upsilon \text{ in radians})$$

Flying at a constant sideslip angle in the turn can produce a large drag increase if the sideslip is excessive, mainly due to the fuselage being partly broadside to the oncoming flow. Hence, it is desirable to design the aircraft so that it doesn't exceed some maximum acceptable steady sideslip angle, especially if it's power-limited in the turn. A suitable maximum β_{turn} value is difficult to choose, but for most aircraft it will likely be in the range

$$\boxed{(\beta_{\text{turn}})_{\text{max}} = 5^\circ \dots 15^\circ} \quad (11)$$

Note that β_{turn} is inversely proportional to Υ . So to reduce the maximum β_{turn} below the limit, especially in a slow turn at high C_L , the dihedral must be made sufficiently large.