



2017 REGULATIONS

8-15 OCT 2017

Document Control

Release version 2 issued 1 September 2017

Changes from previous version

1.7.1 (text updated) ...organised by (Events South Australia)

1.7.1 Address corrected

1.8.1 Titles updated

1.9 List updated

1.12 Addition of the Darwin Waterfront BWSC Festival

2.2.3 has been clarified

2.2.4 formatting amended

2.4.3 example calculation changed

2.4.4 (added text) ...total aperture (area) of the solar collector

2.5.3 (added text) ...of the (cell models) they intend to use

2.5.4 (added text) ...each cell (model) must be specified

2.5.10 (removed text) ...(and) are not considered

2.12.2 (added text) ...(about a vertical axis,) from the forward direction

2.14.1 (added text) ...FAI 8853/98, (FAI 8854/98)

2.16.2 Paragraph re-worded

2.29.5 (added text) ...disc (and the activation mechanism) must be clearly

3.11.2 Location updated

3.18.1 (added text) ...system (or powering the solar car) from an unauthorised

E&OE

© World Solar Challenge

IMPORTANT This printed version may not contain all updates and bulletins.

For the latest information please refer to (www.worldsolarchallenge.org/regulations)

Contents

Introduction and welcome.....	7
1 Administration	9
1.1 Scope	9
1.2 Correspondence	9
1.3 Time zones	9
1.4 Conduct of the event.....	9
1.5 Eligibility.....	10
1.6 Entrant obligation.....	10
1.7 Event organiser.....	10
1.8 Organising committee	10
1.9 Officials of the event	11
1.10 Stewards of the event	12
1.11 Judges of Fact	12
1.12 Schedule.....	12
1.13 Entering the event.....	13
1.14 Entry fees	13
1.15 Other fees.....	15
1.16 Refunds	15
1.17 Cancellation of the event.....	15
1.18 Insurance.....	15
1.19 Team members.....	16
1.20 Team identification.....	16
1.21 Permits	17
1.22 Freight	17
1.23 Visas.....	17
1.24 Vehicle preparation.....	17

1.25	Copyright and Intellectual Property	17
1.26	Sponsorship obligations	18
1.27	Media and promotional obligations.....	18
1.28	Unmanned Aerial Vehicles (Drones)	19
1.29	Compulsory documentation	19
2	Solar car regulations	21
2.1	Classes	21
2.2	Dimensions	21
2.3	Wheels.....	21
2.4	Solar collector	21
2.5	Energy storage	22
2.6	Vehicle identification	24
2.7	Signage	25
2.8	Ballast.....	25
2.9	Tracker	26
2.10	Safety	26
2.11	Occupant cell.....	27
2.12	Seats	27
2.13	Occupant space	28
2.14	Safety-belts.....	29
2.15	Egress	30
2.16	Cooling and hydration	30
2.17	Forward and sideward vision	30
2.18	Rear vision.....	30
2.19	Steering	31
2.20	Stability	31
2.21	Brakes	32
2.22	Tyres.....	33

2.23	Reversing	33
2.24	Lighting	33
2.25	Audible warning device	35
2.26	Instrumentation	35
2.27	Automatic functions.....	35
2.28	Electrical safety.....	36
2.29	Electrical safe state.....	37
3	The Adventure	39
3.1	Supervision	39
3.2	Safety	39
3.3	Safety-belts.....	39
3.4	Helmets	40
3.5	Safety equipment.....	40
3.6	Support vehicles	40
3.7	Escort vehicle signage.....	41
3.8	Communication.....	41
3.9	Heavy vehicles.....	42
3.10	Preparation and testing.....	42
3.11	Team registration and scrutineering.....	42
3.12	Static scrutineering	43
3.13	Dynamic scrutineering	44
3.14	Modifications or changes after scrutineering	45
3.15	Briefings.....	45
3.16	Observers	45
3.17	Start line and grid.....	46
3.18	Energy collection	46
3.19	Route.....	47
3.20	Timing.....	47

3.21	Tracking.....	48
3.22	Solar car drivers and passengers.....	48
3.23	Driving conduct	48
3.24	Stopping	49
3.25	Obstructing other road users.....	49
3.26	Control stops.....	49
3.27	Overnight stops.....	50
3.28	Water spraying.....	51
3.29	Trailing.....	51
3.30	Withdrawal	51
3.31	Penalties.....	51
3.32	Protests and appeals	52
4	Achievement and celebration	53
4.1	Provisional results.....	53
4.2	Completing the course	53
4.3	Challenger class	53
4.4	Cruiser class.....	54
4.5	Adventure class	55
4.6	Awards.....	55
4.7	Pack-down facilities	56

Glossary

2017 Bridgestone World Solar Challenge Regulations

Introduction and welcome

The purpose of the World Solar Challenge is to stimulate research into, and development of, sustainable road transport. The World Solar Challenge is primarily a design competition. The regulatory philosophy is to provide the parameters on which to base the design, rather than specify exactly how to build a solar car. Science and technology evolve and to encourage the most innovative ideas, event requirements also evolve. It is the established practice for the detailed requirements and dates of the competition to be announced on World Environment Day, 5 June, in the year preceding the event.

Participation in the 2017 Bridgestone World Solar Challenge calls for the design and construction of a solar car within given design parameters, and driving the solar car across the continent of Australia in accordance with these regulations.

Each World Solar Challenge is different. Revisions for the 14th edition retain the clear distinction between Challenger and Cruiser classes: Challenger cars will be fast, and Cruiser cars will be practical. The winner of each class will be recognised as holder of the World Solar Cup in their class.

The major changes for 2017 are:

- The maximum allowable size for cars has been increased to allow greater diversity of design, and provisions made to find synergy with other international events.
- Challenger solar collector area has been reduced to 4 m² (for silicon PV) half of what was allowed in the first World Solar Challenge in 1987.
- Cruiser solar collector area is reduced to 5 m² for silicon PV cells, to make it easier to fit a solar collector on a practical car.
- The apertures of solar reflectors and concentrators will be restricted.
- Refinements have been made to the requirements for occupant protection and vehicle dynamics. In addition there is a new requirement for mechanical braking on all road wheels.
- Energy storage limits have been removed for Cruiser Class, which will be run as a single stage 'regularity trial', Success in Cruiser Class will be based on energy efficiency practicality and adherence to time targets.
- Adventure Class will be non-competitive.

The information contained in this document is for the purposes of conducting the 2017 Bridgestone World Solar Challenge and must not be regarded as constituting definitive instructions as to how a solar car should be constructed or operated.

This document is organised as far as practical into the following sections:

- Administration
- Solar car regulations
- Adventure (Darwin and on-road protocols)
- Achievement and celebration.

Additional information or clarification of the intent of regulations is included in italics.

The name 'World Solar Challenge' and the sun device logo are Registered Trade Marks maintained by the Government of South Australia. This work is copyright © World Solar Challenge 2017. The World Solar Challenge asserts its moral right to be identified as the copyright owner of the intellectual property contained in this document whether in physical or electronic form.

1 Administration

1.1 Scope

- 1.1.1 These regulations apply to the 2017 Bridgestone World Solar Challenge® (hereinafter called 'the event'), and comprise participants' eligibility, pre-event preparation, scrutineering, testing, on-road components and any associated activities published by the event organiser as being part of the event.
- 1.1.2 The event will be conducted under the regulations described in this document (which supersede regulations for any previous edition of the World Solar Challenge) and any further regulations or bulletins that may be issued.

1.2 Correspondence

- 1.2.1 All correspondence shall be conducted in English, the official language of the event.
- 1.2.2 Official correspondence will only be conducted between the event organiser and the entrant's nominated representative (normally the team manager) as detailed by the entrant on the entry form. Specific written instruction to include others in team correspondence will be accepted.

1.3 Time zones

- 1.3.1 At the time of the event, Darwin and the Northern Territory observe Australian Central Standard Time (ACST = UTC + 9.5) while Adelaide and South Australia observe Australian Central Daylight Time (ACDT = UTC + 10.5). The event will observe ACST (Darwin time) throughout the journey to Adelaide.
- 1.3.2 After arrival at the finish line, all activities will be conducted in ACDT (Adelaide time).

1.4 Conduct of the event

- 1.4.1 The on-road component of the event is conducted on public roads between Darwin and Adelaide, Australia — a distance of approximately 3000 km. In addition to these event regulations, all activity is conducted under applicable traffic codes, civil laws and regulations.
- 1.4.2 Specific instructions contained in route notes will be considered part of the event regulations.
- 1.4.3 All activities conducted by a registered entrant, including any conducted prior to the commencement of the official event period, are governed by the relevant statutory regulations, breaches of which may incur event penalties.

1.5 Eligibility

- 1.5.1 Eligible vehicles will be those which meet the design criteria described by these regulations. Authority to use public roads must be granted by the civil authorities. Further information will be included in the Team Manager's Guide.

1.6 Entrant obligation

- 1.6.1 Entrants are required to know and understand the regulations of the event and participation will constitute their full acceptance.
- 1.6.2 The manager of each team is responsible for the actions of team members, and any other individuals associated with the team.
- 1.6.3 Entrants are expected to act fairly and in good faith in accordance with the regulations.
- 1.6.4 Penalties (which may include exclusion) will be applied to any team deemed to have departed from the spirit of the event by deliberately acting to gain an unfair advantage over others, or by conduct that could bring the event into disrepute.

1.7 Event organiser

- 1.7.1 The event is organised by Events South Australia, a Division of the South Australian Tourism Commission ('the event organiser').

The Registered Office is:

Bridgestone World Solar Challenge
South Australian Tourism Commission
L3, 121-125 King William Street, Adelaide, South Australia, 5000
Postal address: GPO box 1972, Adelaide 5000
Telephone: +61 8 8212 8500
E-mail: admin@worldsolarchallenge.org
Web: www.worldsolarchallenge.org
ABN: 80 485 623 691

- 1.7.2 The event is owned by the Government of South Australia.

1.8 Organising committee

- 1.8.1 The organising committee is:

- Hitaf Rasheed, Executive Director Events South Australia
- Nathan Cayzer, General Manager Bridgestone World Solar Challenge
- Chris Selwood AM, Event Director, Bridgestone World Solar Challenge.
- Naomi Misiajlo, Event Operations Manager, Bridgestone World Solar Challenge
- Kelvin McAlpine, General Manager Commercial Sales
- Andrew Fotheringham, General Manager Marketing & Communications

1.8.2 Scientific Faculty:

- A/Prof Peter Pudney
- Dr David Rand AM FTSE
- Paul Gwan
- Dr Glenn Platt
- Prof John Storey
- Dr David Snowdon
- Dr John Ward

1.8.3 Operational advisory group:

- Bill Muirhead
- Harry McCallum
- Vince Ciccarello
- Mark Woods

1.9 Officials of the event

Event Director	Chris Selwood AM
Event Operations Manager	Naomi Misajlo
Clerk of the Course	Vince Ciccarello
Deputy Clerks of the Course (Red-Shirts)	Harry McCallum, Tony Schick
Event Officials & Safety Marshals (Red-Shirts)	Ian Basey, James Buchanan Geoff Capper, Robert Clark David Clegg, Jeffrey Gill Bruce Hartley, Christine Haydon Adrianna Ottaway, Ron Ottaway Chris Payne, David Patterson Terry Poustie, Alison Washusen
Control Stop Managers	Kim Bannan, Brian Little, Bohdan Dorniak, Hendrik Vandenberg Jon Marsden, Martin Bull, John Duval Peter Collins, Ricky Reeves
Operations & Logistics Coordinator / Site Manager Hidden Valley	John Pengelly ('JP')
Chief Safety Officer	Peter Schloithe ('Safety Pete')
Chief Medical Officer	Dr Bill Boyd
Chief Participant Liaison Officer	Paige Lepoidevin
Chief Scientist	Prof John Storey
Chief Energy Scientist	Dr David Rand AM FTSE
Chief Scrutineer	Paul Gwan

Chief Timekeeper	Barry Frost
Tracking & Timing Coordinator	Mark Woods
Chief Steward	Roger Brown
Chair of Technical Committee	A/Prof Peter Pudney
International Steward	Leandro Valencia Vio
Cruiser Class Manager	Dr David Snowdon ('Dr Cruise')

1.10 Stewards of the event

1.10.1 The Stewards of the event are the only authority empowered to resolve disputes regarding the interpretation of the regulations.

1.11 Judges of Fact

1.11.1 Each official appointed by the event is considered to be a Judge of Fact on any event-related activity.

1.11.2 Observers appointed by the event are considered to be Judges of Fact on all event-related activities.

1.12 Schedule

5 June 2016 (World Environment Day)	Event dates announced 2017 regulations published Applications for entry open
Friday 21 October 2016	Early Applications close
Friday 31 March 2017	Applications for entry close
Monday 5 June 2017	Entry list published
Friday 30 June 2017	Group A Documentation submission deadline
Friday 28 July 2017	Group B Documentation submission deadline
Friday 25 August 2017	Group C Documentation submission deadline
Tuesday 3 October 2017	Group D Documentation
Tuesday 26 September 2017	Event Headquarters open in Darwin
Tuesday 26 September 2017	Official event period commences
Sunday 1 October 2017	Darwin Waterfront BWSC Festival
Monday 2 October 2017	Team Managers briefing
Tuesday 3 October 2017	Static scrutineering commences

Thursday 5 October 2017	Official Team Welcome function
Friday 6 October 2017	Chief Minister's VIP Reception
Saturday 7 October 2017	Dynamic scrutineering commences
Saturday 7 October 2017	Team briefing
Saturday 7 October 2017	Media briefing
Sunday 8 October 2017	Ceremonial Start in Darwin
Thursday 12 October 2017	Ceremonial Finish Line opens in Adelaide
Friday 13 October 2017	Cruiser class finish
Saturday 14 October 2017	Cruiser class public judging
Sunday 15 October 2017	Award Ceremony
Wednesday 18 October 2017	Pack-down area closes, official event period closes

1.13 Entering the event

Applications for entry are invited from any entrant prepared to meet the standards and obligations of the competition.

- 1.13.1 Applications may be made from the time these regulations are published, until noon Friday 31 March 2017 (ACDT), or such other time as the event organiser may determine.
- 1.13.2 Applications for entry must be made via the official online entry form, available on the [World Solar Challenge website](#).
- 1.13.3 All entries are subject to an application fee.
- 1.13.4 The number of places is limited. Applications received after the limit is reached may be placed on a reserve list.
- 1.13.5 The granting of a place in the event will become void if the entry fees have not been received by the due date.
- 1.13.6 Entrants who do not satisfy the Chief Scrutineer that they will achieve compliance with the regulations (through documentary submission) may fail to qualify for the event and their place may be offered to a team on the reserve list.
- 1.13.7 The Organiser reserves the right to accept or reject any application without explanation.

1.14 Entry fees

The World Solar Challenge is not a commercial operation. The cost of staging an event over three weeks and 3000 km is significant and the organiser, whilst cognisant of the cost of participation, recognises that the basic costs of the operation must be borne by the Entrants.

- 1.14.1 Entry fees include **Australian tax (GST)** and are based on the class requested on the entry form. For example, if a Challenger class team fails to qualify and is offered a place in the Adventure class, no refund of the difference is payable.
- 1.14.2 An application fee of 10% of the total entry fee is required. Payment of this fee will be via credit card as part of the online entry form process. An official tax receipt will be provided via email.
- 1.14.3 The application fee, which forms part of the total entry fee, is non-refundable.

Entrants will be provided with an invoice for the remaining entry fee within one month of receipt of their completed official entry form and application fee. Acceptable methods for payment of entry fees will be detailed in the invoice document.

- 1.14.4 International banking charges are the responsibility of the entrant. Minor adjustment (up to AU\$150) can be settled at registration in Darwin.
- 1.14.5 Applications submitted before 17:00 (ACDT) on Friday 21 October 2016 will be considered an Early Entry and qualify for the Early Entry fee.

Early entry fees must be paid in full by 31 October 2016. Failure to pay by due date will void the qualification for Early entry fees and a secondary invoice will be issued for the Standard entry fee.

- 1.14.6 Applications received after 17:00 (ACDT) on Friday 21 October 2016 and before 17:00 (ACDT) on Friday 31 March 2017 will qualify for the Standard entry fee.
- 1.14.7 All entry fees are payable in full by 17:00 (ACDT) Wednesday 31 May 2017; failure to pay by the due date will void the application. Any refund will be subject to the terms outlined under Regulation 1.16.
- 1.14.8 The entry fees are:

Class	Early Entry Fee	Standard Entry Fee
Challenger	AU\$12,000	AU\$13,200
Cruiser	AU\$12,000	AU\$13,200
Adventure	AU\$10,000	AU\$11,000

- 1.14.9 The organiser reserves the right to accept late entries. Entry requests granted after the close of entries will attract a 10% late fee.

All enquiries regarding fees or payments should be directed to Participant Liaison via email teams@worldsolarchallenge.org or phone +61 8 8212 8500 during (Central Australian) business hours - 0900-1630 Monday-Friday).

1.15 Other fees

- 1.15.1 A fee of AU\$30 will be levied on each team member travelling from Darwin to Adelaide. This fee will include remote area air-ambulance emergency evacuation insurance, and is payable in Darwin.
- 1.15.2 A fee (estimated at AU\$76) will be payable to the Motor Accident Commission by the owner of each solar car in respect of compulsory third party bodily injury insurance required by operators of motor vehicles.

1.16 Refunds

- 1.16.1 Refund entitlement is based on date of withdrawal. The application fee and bank charges are not refundable.

Withdrawal date	Refund
Before 31 March 2017	Full refund
Before 30 June 2017	85% refund
Before 25 August 2017	50% refund
After 25 August 2017	No refund

1.17 Cancellation of the event

- 1.17.1 The event organiser reserves the right to cancel or abandon the event for any reason. The organiser's liability for costs incurred by an entrant are limited to the amount of the entry fee received (including application fee).

1.18 Insurance

- 1.18.1 The event organiser holds a \$20,000,000 Public Liability policy which covers registered participants. The cost of this coverage is included as part of the entry fee.
- 1.18.2 The event organiser will arrange for Third Party Bodily Injury insurance required to operate the solar car on public roads, a fee for which may be payable by the owner of the vehicle.
- 1.18.3 Cover has been arranged to cover any claims on the event organiser for damage caused by a participating solar car during the event. The cost is part of the entry fee.
- 1.18.4 Comprehensive insurance for personal effects, tools, equipment, solar cars and other vehicles is the responsibility of the entrant.

Participants are advised that a personal travel insurance policy in respect of theft, loss, sickness and accidents is highly recommended. The Australian Government has reciprocal agreements covering limited subsidised health services for medical treatment with some countries through Medicare. More detailed information can be found at [Medicare Australia](#). The event organiser will

ensure that the costs of remote area evacuation and emergency medical treatment are covered in the event of an accident. As this can be tens of thousands of dollars, the fee described in Regulation 1.15.1 will be levied on each individual team member travelling from Darwin to Adelaide as part of the event.

1.19 Team members

1.19.1 Each team must include (but not be limited to):

- Team Manager
- Safety Officer
- Battery Officer
- an interpreter if the Team Manager is not proficient in English
- at least two and at most four solar car drivers
- at least two drivers for each support vehicle
- at most eight registered solar car passengers (for Cruiser class).

1.19.2 Each team member will be required to register online, and be physically present at team registration in Darwin.

1.19.3 A person holding the position of Team Manager, Safety Officer or Battery Officer may not hold any other of these roles.

1.19.4 Each solar car driver must hold an appropriate motor vehicle driver's licence recognised by Australian authorities and valid for the total period of the event.

Driving licences will be inspected and verified by Australian road transport authorities as part of the scrutineering process. Acceptable driving licences must include a photograph of the holder, the class of vehicle for which the licence applies and the expiry date. If these details are not in English, either the licence must be accompanied by a certified translation, or a valid International Driving Licence is required.

1.19.5 Every solar car driver must have a minimum experience of 12 hours driving the solar car, as demonstrated by the presentation of a log book and a signed declaration by the team manager.

1.19.6 The event organiser is unable to take responsibility for any person born after 25 September 1999.

An entrant may make a request for a minor to be included in their team provided such request is accompanied by a document giving permission and acknowledging that supervision of the person concerned is the responsibility of the team manager, not the event organiser. The document must be signed by both the parent or legal guardian of the proposed participant, and the team manager.

1.20 Team identification

1.20.1 Team and solar car names will be taken from the online entry form.

1.20.2 A request to change entry details must be made in writing by the team manager to teams@worldsolarchallenge.org and will be subject to the approval of the event organiser.

- 1.20.3 Each team will be allocated a team number on acceptance of entry.
- 1.20.4 Early entry applications may make a special request for the use of a particular team number. Requested numbers should contain two digits. '01' is the privilege of the current holder of the World Solar Cup.
- 1.20.5 Allocation of any number is at the sole discretion of the event organiser.

1.21 Permits

- 1.21.1 Motor vehicles entering Australia require a federal import permit.

The organiser will make application on behalf of solar cars entered.

- 1.21.2 Import permit arrangements for other vehicles (including road trailers) are the responsibility of the entrant.

1.22 Freight

- 1.22.1 The event organiser will appoint a freight agent licensed by Australian Customs Service.
- 1.22.2 Freight deliveries to the Hidden Valley Motorsport Complex outside the dates of the event will not be accepted.

Details of all freight, customs and quarantine arrangements will be provided in the Team Manager's Guide.

1.23 Visas

- 1.23.1 Citizens of countries other than Australia or New Zealand need a visa to enter Australia.

Details of visa requirements can be found from the Australian [Department of Immigration and Border Protection](#). The event is registered with the Australian Department of Immigration and Border Protection. Details of how the event organiser is permitted to support visa applications will be provided in the Team Manager's Guide.

1.24 Vehicle preparation

- 1.24.1 Preparation facilities will be available at the Hidden Valley Motorsport Complex in accordance with the dates listed in the schedule.

Responsibility for all operations at the Hidden Valley site is with the event organiser. Hidden Valley management are unable to assist with early arrivals, pit allocations or freight issues. Detailed arrangements will be published in the Team Manager's Guide.

1.25 Copyright and Intellectual Property

- 1.25.1 The Government of South Australia is the owner of the Intellectual Property of the Event, and owns the copyright and trademarks of the World Solar Challenge.

- 1.25.2 It is a condition of participation that the entrant acknowledges that the intellectual property of the event is owned by the event organiser, and as such the event organiser holds the right to license any and all commercial, or non-commercial, depictions of the event in any form including—but not limited to—electronic, print or other media.
- 1.25.3 The correct title of the event is the *Bridgestone World Solar Challenge*. The correct title is the *Word Mark* of the event. Entrants and their sponsors **must** use the correct title in all references to the event.
- 1.25.4 The *Official Logo* of the event will be published as an appendix to these regulations. The *Official Logo* will be supported by a style guide that details its conditions of use.
- 1.25.5 Registered entrants and their sponsors wishing to use the *Word Mark* and *Official Logo* in non-commercial publicity may do so in accordance with the requirements of the style guide.
- 1.25.6 Registered entrants and their sponsors wishing to use the *Word Mark* and *Official Logo* in a commercial context (i.e. merchandise offered for sale) must seek the written permission of the event organiser.
- 1.25.7 Individual teams or their sponsors may not represent ‘whole of event’ data as their own.
- 1.25.8 Notwithstanding the provisions of Regulation 1.27.6, the event organiser will respect the Intellectual Property of the respective owners.

1.26 Sponsorship obligations

- 1.26.1 It is a condition of participation that the entrant acknowledges event and category sponsors in their own publicity. Failure to do so may result in the team being delisted from event publicity.

1.27 Media and promotional obligations

A promotional schedule will form part of the schedule of activities. The promotional schedule will contain details of official media calls and other promotional activities created for the benefit of the event, the entrants and their sponsors.

- 1.27.1 Teams must attend official media calls with the solar car and any other team vehicles or equipment requested.
- 1.27.2 Registered entrants must notify the event organiser of public or media promotional activities held for or on behalf of their attendance in the event, not less than 7 days prior to the activity taking place. Commercial In Confidence and media embargos will be honoured.
- 1.27.3 Media travelling with or in support of any team must meet, and act, in accordance with the event media accreditation requirements.

- 1.27.4 Entrants will be held accountable, through the application of event penalties, for the unacceptable actions of media representatives travelling with or in support of their team, whether registered as such or not.

Standard operational procedure of Australian police is to first remove the cause of any problem. Police have advised that, where media vehicles following a particular team are creating a danger for other road users, they will take the solar car off the road. Teams are advised to reinforce this point in their own language.

- 1.27.5 Registered entrants who maintain an internet presence are required to provide a link to the official Bridgestone World Solar Challenge website: www.worldsolarchallenge.org.
- 1.27.6 By entering the event, entrants implicitly agree to the use, in perpetuity, of their names, images, depictions and technical data of their vehicles, equipment and crew, in any publicity material generated by the event, its sponsors or licensees.
- 1.27.7 The creation and use of any sound recordings or still or moving images of the event used for commercial gain or public performance by the entrant or their sponsors are subject to the prior written approval of the event organiser, and any terms and conditions imposed as part of the approval process. Teams are advised to contact the event organiser prior to entering into any commitment (for example as a condition of individual team sponsorship) for any such commercial arrangement, as failure to observe these conditions may lead to Breach of Copyright action by the State of South Australia.
- 1.27.8 Non-commercial media content generated by the entrant must reference the event in accordance with the provisions of Regulation 1.25.3.
- 1.27.9 Teams or their sponsors shall not engage in any marketing or promotional activity that will materially detract from the value and standing of the sponsors of the event.
- 1.27.10 Activity by sponsors of teams shall not imply ownership of the event.
- 1.27.11 Entrants are responsible for the activities of their sponsors.

1.28 Unmanned Aerial Vehicles (Drones)

- 1.28.1 Unmanned Aerial Vehicle (UAV/drone) operations may be conducted only with the approval of the event organiser.
- 1.28.2 Unmanned Aerial Vehicle (UAV/drone) operations must be conducted in accordance with the [policy document](#) of the Confederation of Australian Motor Sport.
- 1.28.3 Unmanned Aerial Vehicle (UAV/drone) operations must comply with [Australian regulations governing the use of Remotely Piloted Aircraft](#).

1.29 Compulsory documentation

- 1.29.1 Each team must submit the following documentation using templates provided, by the dates stated in the event schedule. Documents are divided into four groups.

Group A

- General Specification
- Electrical System Specification
- Solar Collector Specification
- Energy Storage System Specification.

Group B

- Battery Incident Plan
- Team Safety Plan
- Publication-quality information and photographs of the team and solar car.

Group C

- Logistics schedule
- Travel, arrival and accommodation information.

Group D

- Two printed A4 copies of a diagram (plan view, front of the solar car at the top), clearly showing how emergency isolation is to be activated.
- The original signed Roadworthiness Certificate.
- A simplified wiring diagram, printed on A4 paper, showing how the main functional blocks (PV array, energy storage packs, electronics modules, etc.) are connected together, together with circuit breakers, contactors and fuses.

1.29.2 Any requests to make changes to items described in the compulsory documentation, after the submission deadline, must be sent to the event organiser in writing by the Team Manager. If granted, any document submitted by a team will supersede all previous versions.

2 Solar car regulations

2.1 Classes

2.1.1 The 2017 Bridgestone World Solar Challenge will have three classes of solar car:

- **Challenger** class is for single-seat solar cars designed to be fast.
- **Cruiser** class is for efficient, practical solar cars with two or more seats.
- **Adventure** class is for solar cars designed to participate in previous events but not eligible for Challenger or Cruiser class. Adventure class is non-competitive.

2.2 Dimensions

2.2.1 When driving in a straight line, the solar car must fit inside a right rectangular prism 5000 mm long, 2200 mm wide and 1600 mm high, with the base of the prism coincident with the ground.

2.2.2 The eyes of every occupant must be more than 700 mm above the ground.

2.2.3 The fully-laden solar car must be able to drive off a road with a 50mm vertical edge drop without any part of the solar car, other than the tyres, touching the ground.

2.2.4 Future International Solarcar Federation (ISF) regulations will allow supplementary solar collectors for some events. Challenger Class solar cars must include internal space to carry supplementary solar collectors: 2m² if the main solar collector uses Si cells, 1.78m² if the main solar collector uses thin film GaAS cells, or 1.32m² if the main solar collector uses multijunction cells. Supplementary solar collectors will not be allowed in the 2017 Bridgestone World Solar Challenge; this space must be empty.

2.3 Wheels

2.3.1 Challenger and Cruiser solar cars must be supported by four wheels: two front wheels and two rear wheels. Points of contact between the tyres and the road must be symmetrical about the longitudinal centreline of the solar car.

2.3.2 For Challenger and Cruiser solar cars, the distance between the front tyre centres and the distance between the rear tyre centres must each be more than half the width of the solar car.

2.4 Solar collector

2.4.1 The primary energy source for a solar car is solar irradiation collected by the solar car.

A standard solar collector uses photovoltaic cells without reflectors or concentrators. Teams wishing to use some other form of solar collector must contact the event organiser.

2.4.2 If the solar collector comprises photovoltaic cells all of the same chemistry and used without concentrators such as reflectors or lenses then the total cell area, found by

summing the exposed surface areas of the component photovoltaic cells, must not exceed the allowable total cell area:

Class	PV Cell Chemistry	Allowable Total Cell Area (m ²)
Challenger	Si	4.000
	thin film GaAs	3.560
	multijunction	2.640
Cruiser	Si	5.000
	thin film GaAs	4.440
	multijunction	3.300

2.4.3 Teams must provide calculations that demonstrate compliance.

Example calculation: The area of a SunPower E60 cell is less than 0.015333m², and so the area of 260 cells is less than 3.987 m² and the area of 326 cells is less than 4.999m².

2.4.4 If the solar collector comprises photovoltaic cells used with concentrators such as reflectors or lenses then the total aperture area of the solar collector must not exceed the allowable total cell area, by cell chemistry, for non-concentrator photovoltaic solar collectors. Teams wishing to use concentrator photovoltaic solar collectors must contact the event organiser for more information.

2.4.5 Teams wishing to use other solar collector types, or a mix of solar collector types, must contact the event organiser and provide details of their proposed collector. Useable power should be equivalent to that of a non-concentrator photovoltaic solar collector.

2.4.6 *This regulation (The solar collector may be reconfigured ... only while ... stationary) has been removed.*

2.4.7 All devices used for solar charging must be carried in the solar car. This includes stands, supports and cables.

2.5 Energy storage

A solar car may store energy. A standard energy storage system uses rechargeable electrochemical cells. Teams wishing to use some other form of energy storage must contact the event organiser.

2.5.1 If the energy storage system comprises rechargeable electrochemical cells all of the same chemistry then the allowable total cell mass for Challenger and Adventure solar cars is:

Electrochemical Cell Chemistry	Allowable Total Cell Mass (kg)
Li-S	15.00
Li-ion	20.00
Li-polymer	20.00
LiFePO ₄	40.00

- 2.5.2 Teams must contact the event organiser for the allowable total cell mass if other cell chemistries or a mix of cell chemistries is proposed.

The allowable total cell mass of rechargeable electrochemical cells is not restricted for Cruiser solar cars. However, the external energy used by a Cruiser class solar car, including the energy stored at the start, will contribute to its energy efficiency score.

- 2.5.3 Teams must submit detailed specifications of the cell models they intend to use.

- 2.5.4 The nominal mass of each cell model must be specified and endorsed by the manufacturer.

Specifications from third party suppliers or found on the internet might not match those endorsed by manufacturers.

- 2.5.5 If the event organiser receives conflicting or unclear specifications of nominal cell mass for a particular cell model, the Chief Energy Scientist will determine the nominal cell mass for cells of that model.

- 2.5.6 The sum of the nominal cell masses (i.e., summed over all cells) must be not more than the allowable total cell mass.

- 2.5.7 The energy storage system must be contained within at most two packs.

- 2.5.8 Electrochemical cells must not, at any time, be operated outside of the operating ranges for voltage, current and temperature specified by the manufacturer.

Teams must provide documentation that describes how they monitor their electrochemical cells, and what the team and the solar car will do if any cell goes outside specified operating limits. Teams must obtain endorsement by their certifying engineer that an adequate and effective monitoring regime has been designed and implemented, and that any fault condition can be safely managed.

- 2.5.9 Any charging system with ac input that is used to recharge the energy storage system (when allowed) must meet the following requirements:

- the charger must be used with a residual current device
- the charger must be either permanently connected to the energy storage system, or connect to the energy storage system using an appropriate connector
- the output of the charger must be electrically isolated from the ac input
- the charger must stop charging automatically when the energy storage system is full or if a fault occurs.

- 2.5.10 Batteries used only to

- power a real time clock when the solar car is turned off; or
- retain data when the solar car is turned off; or
- power wireless tyre pressure monitors

are not considered to be part of the energy storage system, provided that the total energy capacity does not exceed 2.0 Wh.

- 2.5.11 Batteries or cells inside devices such as handheld radios, cameras, mobile telephones or wristwatches that are carried by the driver are not considered to be part of the energy storage system, provided that they are not electrically connected to the solar car, its instrumentation or control systems.
- 2.5.12 Capacitors are not considered to be part of the energy storage system if their total energy storage capacity is less than 10.0 Wh. Such capacitors must be automatically discharged to less than 60 V within five seconds of the solar car being placed in safe state (see Regulation 2.29).

An external battery is not necessary to start a solar car. Possible alternatives include:

- *Use a small galvanically isolated dc/dc converter inside an energy storage pack to supply voltage to a remote start switch. You can use a separate switch on the energy storage pack to turn off this dc/dc converter if it is not going to be used for an extended period.*
 - *If the driver can reach the energy storage pack, put the start switch on the energy storage pack.*
 - *Use an air switch inside an energy storage pack, with an air line to a remote start button.*
- 2.5.13 Energy storage packs must be mounted in the solar car so that they will be restrained in a 20 g acceleration.
- 2.5.14 If an energy storage pack is capable of spilling dangerous liquids when damaged, there must be a spill-proof barrier between that energy storage pack and the solar car occupants.
- 2.5.15 If an energy storage pack is capable of emitting dangerous gases when damaged, the solar car must be designed so that any gases will be vented to the exterior of the solar car behind any occupant ventilation intake.
- 2.5.16 Removable energy storage packs enable teams to work on their solar car while their energy storage packs are impounded. If energy storage packs are removable then:
- each energy storage pack must remain in safe state while not connected to the solar car
 - the team must provide a lockable box for storing energy storage packs while they are impounded.
- 2.5.17 Energy storage packs must be constructed so that each pack can be sealed using tamper-evident plastic seals, similar to 3 × 100 mm plastic cable ties. With seals fitted, it must not be possible to remove any cell from a pack without breaking the seal. Seals will be provided by, and fitted by, the event organiser at scrutineering.

2.6 Vehicle identification

- 2.6.1 The solar car must have a unique Vehicle Identification Number (VIN), which must be permanently attached to a substantial part of the solar car chassis or frame.

VINs meeting the requirements of the event can be issued by the [International Solarcar Federation](#).

- 2.6.2 Solar cars must have a flat vertical surface 220 mm wide and 110 mm high on which a rear licence plate will be mounted. The licence plate must be readable from every position behind the licence plate in the range 15° up, 0° down, 45° left and 45° right.

2.7 Signage

- 2.7.1 Unbroken rectangular spaces 200 mm high and 500 mm wide must be provided on both the left and the right sides of the solar car for event signage. Event signage will be provided by the event organiser at scrutineering.
- 2.7.2 Teams must display their team number on the left and the right sides of the solar car, in digits that are more than 150 mm high and that are clearly visible against their background.
- 2.7.3 Event signage and team numbers must be completely visible from a distance of 3 m perpendicular to the side of the solar car and at a viewing height of 1.8 m above the ground.
- 2.7.4 Solar cars must have an unbroken front signage area on the solar car body at the front of the car. The projection of a 600 mm × 150 mm rectangle onto the solar car body, perpendicular to the plane of the rectangle (see the diagram below), must fit entirely within the front signage area. The entire front signage area must be visible in plan view and in front elevation view, and must not overlap with the solar collector. Part of the front signage area must be further forward than every part of the solar collector. A 150 × 150 mm event logo must be placed within the front signage area; artwork or a sticker will be provided by the event organiser. The front signage area should also include the name of the team or the name of the car.



- 2.7.5 The national flag of the country of entry must be displayed on the solar car, adjacent to the windscreen. Minimum size is 70 mm × 40 mm.

2.8 Ballast

- 2.8.1 Ballast will be supplied by the organiser in the form of steel shot packed in canvas bags.

The approximate density of the ballast material is 5 kg per litre. Ballast provided by teams will not be accepted.

- 2.8.2 The solar car must have a means of securing ballast within 300 mm of the hip point of each occupant, in a position accessible by the observer.
- 2.8.3 The combined mass of each occupant and their ballast must be at least 80 kg.
- 2.8.4 Ballast bags must be returned to the pack-down area at the conclusion of the event.

2.9 Tracker

- 2.9.1 The solar car must have provision to carry a self-contained tracker provided by the event organiser.

The box will be at most 200 mm long, 150 mm wide and 100 mm high. The upper face of the box will be marked with a circular window with a diameter of 125 mm, as shown in the diagram. The tracker will be self-powered. It will not require any electrical connection from the solar car. The mass of the tracker will not exceed 5 kg. The unit will be given to the team for installation during scrutineering.

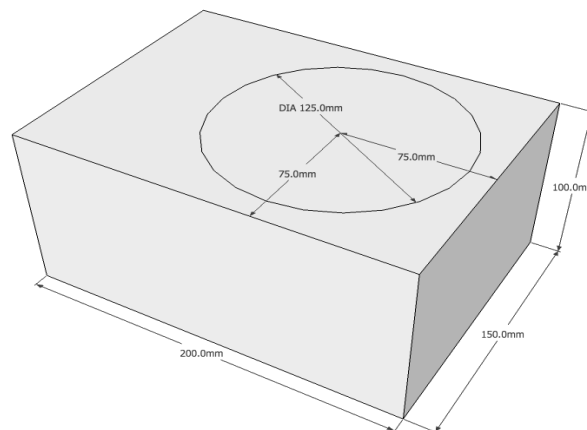

- 2.9.2 When the tracker box is installed in the car, it must be possible to construct a right circular cone with an apex angle of 120° , and to orient the cone so that the circular window is entirely within the cone, and no ray from the apex and within the cone passes through the ground or through any part of the car that is not radio-transparent at frequencies between 300 and 3000 MHz.
- 2.9.3 The tracker unit must be returned to the organiser at the conclusion of the event.

2.10 Safety

- 2.10.1 Teams are responsible for the safety and roadworthiness of their solar cars. Compliance with the regulations and passing scrutineering does not mean that a solar car is safe, roadworthy, and fit for purpose.
- 2.10.2 Each team must engage a professional engineer, who must certify that the solar car is designed and constructed using sound engineering practice, and is roadworthy and fit for purpose.

- 2.10.3 The event organisers may, at any stage, remove a solar car from the event if they consider the solar car or the behaviour of the team to be unsafe.

2.11 Occupant cell

- 2.11.1 Solar car occupants must be enclosed in an occupant cell designed to protect them from injury.
- 2.11.2 Teams must provide documentation that specifies which parts of their solar car constitute the occupant cell.
- 2.11.3 When occupants are seated normally, with safety-belts and helmets on, no part of any occupant or their helmet may intersect with the convex hull of the occupant cell.
- 2.11.4 No point of any occupant's helmet may lie within 50 mm of the convex hull.

Imagine stretching a rubber skin around the occupant cell; no part of any occupant may touch the skin, and helmets must be more than 50 mm from the skin.

- 2.11.5 Each team must provide calculations, certified by the team's certifying engineer, to show that the occupant cell will not deform by more than 25 mm and will not fail at any point when subjected to the following load cases, based on the fully-laden mass of the solar car:
- frontal impact: a 5 g load, opposing the direction of travel, applied to the front of the occupant cell in an area less than 250 mm high and less than 600 mm wide
 - side impact: a 5 g load into the side of the safety cell, applied adjacent to the driver's torso in an area less than 250 mm high and less than 600 mm wide
 - top impact: loads of 5 g down, 1.5 g sideways and 4 g backwards, applied simultaneously at each area of contact between the occupant cell and the ground when the occupant cell is upside down; the contact area for each test load must have a diameter less than 150 mm.
- 2.11.6 The solar car body and occupant cell must be designed so that parts, such as the solar collector, cannot detach and injure occupants.

To reduce the risk of injury from impacts, the interior of the occupant cell adjacent to each occupant's pelvis, abdomen, thorax and shoulder should be covered with energy absorbing material at least 50 mm thick and with a compressive strength of 500–1000 kPa.

2.12 Seats

- 2.12.1 Cruiser solar cars must be designed to carry more than one occupant.
- 2.12.2 Each solar car occupant must have a seat that faces forward at an angle less than 10°, about a vertical axis, from the forward direction of travel.
- 2.12.3 Each seat must have a back and a head restraint. The distance from the hip point to the top of the head restraint must be at least 800 mm for front seats and at least 750 mm for

rear seats (UNECE Regulations 17 and 25). The hip point may be approximated as shown in the diagram below.

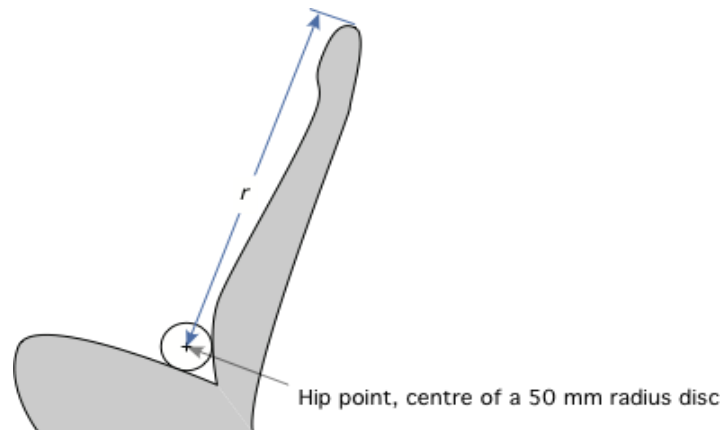

2.12.4 Each occupant's heels must be below their hip point.

2.12.5 The angle between each occupant's shoulders, hips and knees must be more than 90°.

2.13 Occupant space

2.13.1 Occupant space for each seat must comply with Section LK of the Australian National Code of Practice for Light Vehicle Construction and Modification, as shown in the following diagram. The 835 mm radius arm must be able to move 45° forwards, 25° backwards and 7° either side of vertical. The solar car structure, including the windscreen, must lie wholly outside the occupant space. The steering wheel, mirrors, seat backs and head restraints may be inside the occupant space, but must be designed to minimise the risk of injury in a crash.

This minimum occupant space requirement is based on a 50-percentile male and does not allow for a helmet. Taller team members may need more occupant space.

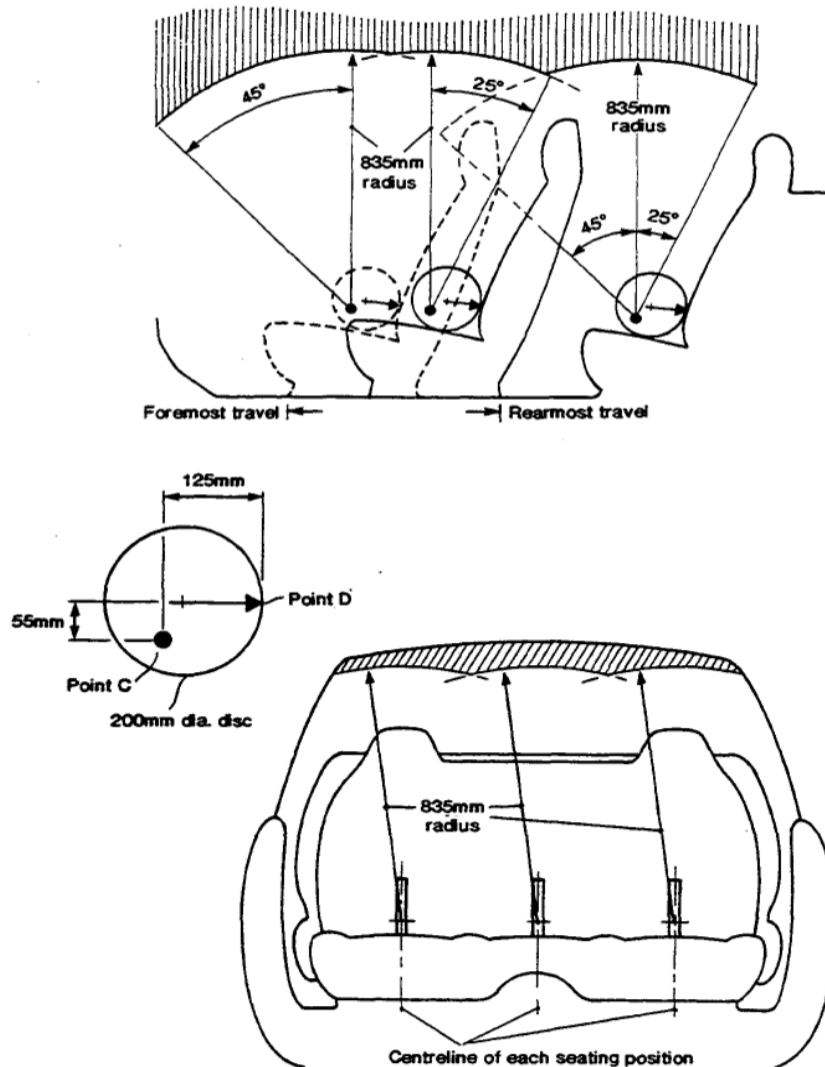

2.14 Safety-belts

2.14.1 Safety-belts must be fitted for each seating position. Safety-belts must be compliant with at least one of the following standards: UNECE Regulation 16, US FMVSS 571.209, SFI 16.1, SFI 16.5, FAI 8853/98, FAI 8854/98.

The occupant cell will provide the greatest protection when occupants are secured into the cell with four-point or five-point harnesses.

2.14.2 Safety-belts must be fitted and used according to the manufacturer's instructions.

2.14.3 Safety-belt anchorages must meet the intent of UNECE Regulation 14. In particular:

- upper anchorages for each seat must withstand a force of 13.5 kN applied to the upper safety-belt straps
- lower anchorages for each seat must withstand a force of 13.5 kN applied to the lower safety-belt straps
- the location of anchor points must comply with the instructions of the safety-belt manufacturer, or with UNECE Regulation 14 Annex 3.

2.14.4 Compliance must be confirmed by the team's certifying engineer.

2.15 Egress

2.15.1 Teams must demonstrate that all occupants can exit the solar car in less than 15 seconds, without assistance.

2.15.2 Doors and canopies must be capable of being secured and released from inside the solar car and from outside the solar car.

2.15.3 Emergency openings, and the methods of opening, must be clearly indicated on the exterior of the solar car, and be visible to an emergency services first responder.

2.15.4 Except in emergency, occupants must exit the solar car without assistance during the event.

2.16 Cooling and hydration

2.16.1 Each solar car occupant must be provided with ventilation or cooling sufficient to ensure that they will not overheat. The team must describe the system and have it approved by their certifying engineer.

2.16.2 Each solar car occupant must have at least two litres of drinking water in the solar car at the beginning of each day and when departing each control stop.

2.17 Forward and sideward vision

2.17.1 Each driver, when seated in the normal driving position with safety-belt and helmet on, must be able to identify 75 mm high letters at every point of forward travel that is:

- 4 m from the driver's eyes, and
- between 0.4 m below eye level and 0.7 m above eye level, and
- between 100° left and 100° right of the direction of travel.

2.17.2 Forward and sideward vision must be achieved without the aid of mirrors, lenses or electronic vision systems.

2.17.3 The windscreen used for forward and sideward vision must have an optical transmittance more than 75%.

2.17.4 Traffic light colours must be discernable through the windscreen.

2.18 Rear vision

2.18.1 The solar car must have rear vision systems that enable the driver, when seated in the normal driving position with the safety-belt fastened, to see the ground in the shaded areas shown in the diagrams below (UNECE Regulation 46, Section 15).

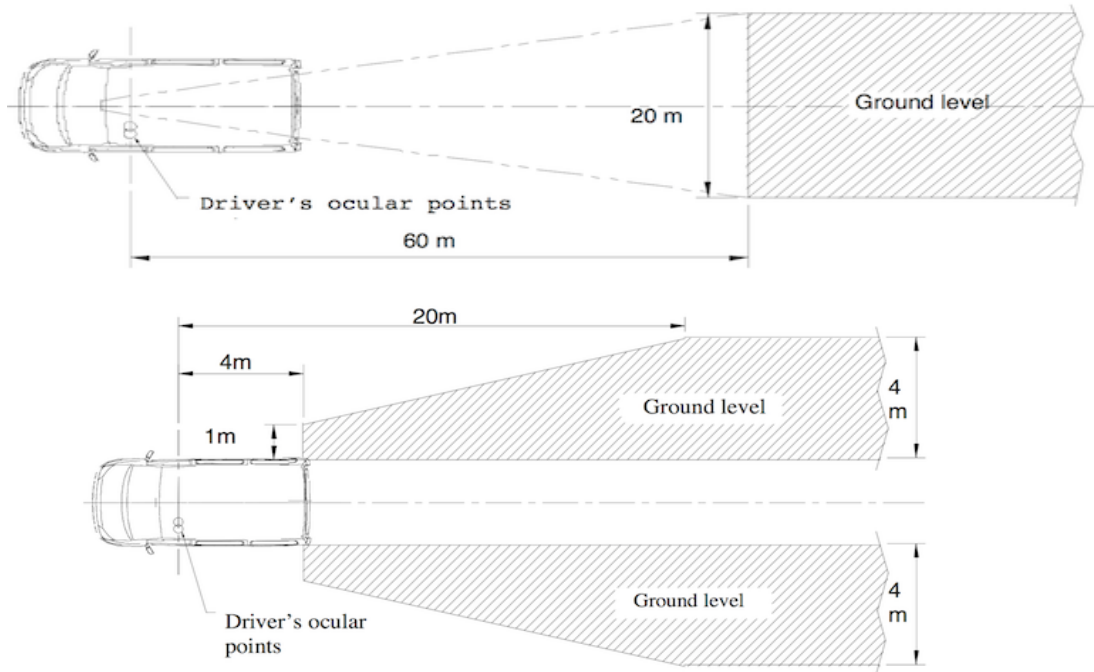

2.18.2 Rear vision systems may be electronic, mirrors, or both. Rear vision systems must operate whenever the solar car is in motion under its own power. Rear vision images must be oriented so that objects on the right of the solar car are on the right of the image.

2.19 Steering

2.19.1 Steering must be controlled by a steering wheel designed so that it cannot catch on clothing while driving or when the driver exits the solar car.

2.19.2 Failure of any non-mechanical component of the steering system must not prevent effective steering of the solar car.

2.19.3 Steering shafts must be designed so that they will not spear the driver in a crash. A collapsible boss is an acceptable method to reduce steering wheel impacts.

2.20 Stability

2.20.1 Solar cars must be able to negotiate a Figure-8 course in less than 9 seconds per side and less than 18 seconds overall.

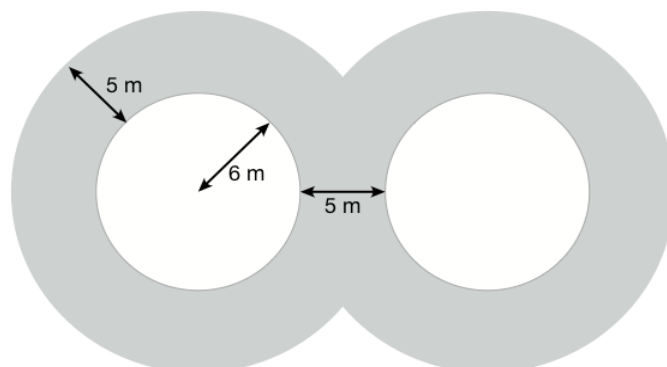

2.20.2 Solar cars must be able to negotiate a slalom course in less than 11.5 seconds.

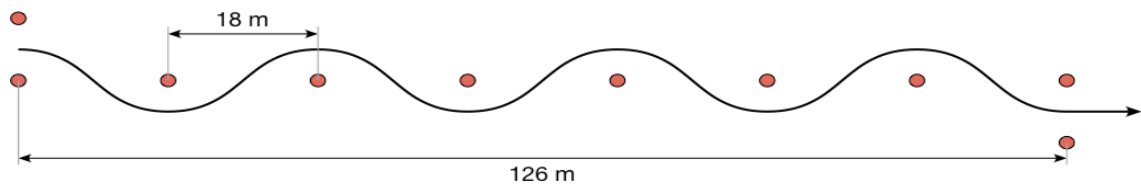

2.20.3 The solar car must be stable at all achievable speeds and in crosswinds.

Wind gusts exceeding 100 km/h are possible.

2.21 Brakes

Braking requirements are based on UNECE Regulation 13-H.

2.21.1 The braking system must be approved by the team's certifying engineer.

2.21.2 The solar car must be equipped with independent primary and secondary mechanical braking systems, so that if the primary system fails the secondary system can still stop the solar car.

2.21.3 Independent braking systems may share components deemed 'not liable to failure' provided that they are amply dimensioned and readily accessible for maintenance. Components 'not liable to failure' are:

- a brake pedal and its bearing
- hydraulic cylinders and their pistons
- hydraulic control valves
- brake cylinders and their pistons
- brake lever and cam assemblies.

2.21.4 Hydraulic brake hoses and lines are regarded as liable to failure.

2.21.5 For Challenger and Cruiser class vehicles, the primary braking system must apply mechanical braking effort to all road wheels.

2.21.6 Braking must not cause the solar car to yaw. This requirement applies to both the primary braking system and the secondary braking system.

2.21.7 For solar cars without anti-lock brakes, the front wheels must lock up before the rear wheels.

2.21.8 The primary braking system must be able to stop the fully laden solar car within distance

$$0.1 v + 0.0060 v^2$$

metres from any speed v , in km/h, that the solar car can achieve.

2.21.9 If the primary braking system fails, the secondary braking system must be able stop the fully laden solar car within distance

$$0.1 v + 0.0158 v^2$$

metres from any speed v , in km/h, that the solar car can achieve.

- 2.21.10 Solar cars must be equipped with a parking brake that can be operated by the driver from the normal driving position. The parking brake must be capable of holding the fully-laden solar car on a 20% incline or decline.

2.22 Tyres

- 2.22.1 Tyres must be approved by the certifying engineer.

- 2.22.2 Solar cars must be fitted with tyres that are:

- compliant with UNECE Regulation 30, UNECE Regulation 75 or US FMVSS 571.109, as indicated by a DOT or E approval marking on the tyre; or
- otherwise approved by the event organiser.

Teams wishing to use tyres that do not have appropriate approval markings must be approved by the Australian road traffic authorities. The event organiser will administer this process, which requires the tyre manufacturer to submit a sample tyre and written technical specifications to the event organiser's office not later than 30 April 2017. A positive outcome to the approval process, which may take up to three months, is not *guaranteed*.

- 2.22.3 The speed rating of the tyres must be more than the maximum speed of the solar car. The load rating of the tyres must be more than the maximum static load imposed by the fully-laden solar car.
- 2.22.4 Tyres must be used in accordance with their manufacturer's recommendations at all times.
- 2.22.5 Tyres must be free of any apparent defect.

2.23 Reversing

- 2.23.1 Solar cars must be able to be driven backwards under their own power with the driver seated in the normal position.

2.24 Lighting

- 2.24.1 Solar cars must be fitted with:

- two rear stop lamps
- one central stop lamp
- left and right front direction indicator lamps
- left and right side direction indicator lamps
- left and right rear direction indicator lamps

- 2.24.2 Stop lamps must emit red light. Direction indicator lamps must emit amber light.

- 2.24.3 Lamps must be compliant with UNECE Regulations 6, 7 and 37, or the SAE/DOT equivalents. Teams must demonstrate compliance by either:

- the presence of compliance markings on the lamps, or
- documentation confirmed by the certifying engineer.

2.24.4 Solar cars must have the correct type of lamp in each position. For example, side marker lamps may not be used as stop lamps.

Lamp position and visibility requirements are based on UNECE Regulation 48.

2.24.5 Rear stop lamps must be within 400 mm of the extreme outer edge of the solar car on each side, at least 600 mm apart (at least 400 mm apart if the solar car is less than 1300 mm wide), and at least 350 mm above the ground. They must be visible 15° up, 5° down and 45° to the left and right.

2.24.6 A central stop lamp is required. Viewed from behind the solar car, the lateral position of the lamp must coincide with the visual centre of the solar car (see the examples in the following diagram). The lamp must be higher than a point 150 mm below the rear windscreen or canopy. The lamp must be visible 10° up, 5° down and 10° to the left and right.

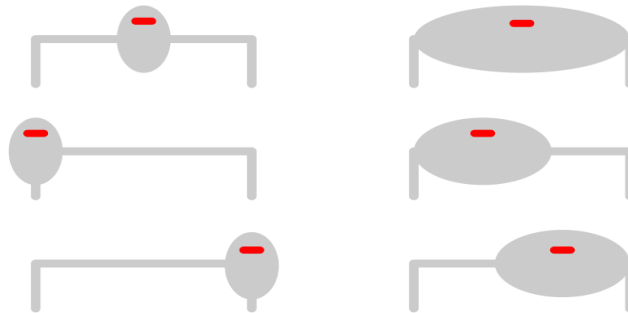

2.24.7 Front and rear direction indicator lamps must be within 400 mm of the extreme outer edge of the solar car on each side, at least 600 mm apart (at least 400 mm apart if the solar car is less than 1300 mm wide), and at least 350 mm above the ground.

2.24.8 Side direction indicator lamps must be less than 1800 mm behind the front most part of the solar car.

2.24.9 Direction indicator lamps must be visible 15° up and 5° down. Minimum horizontal visibility requirements of the right direction indicator lamps are shown in the following diagram.

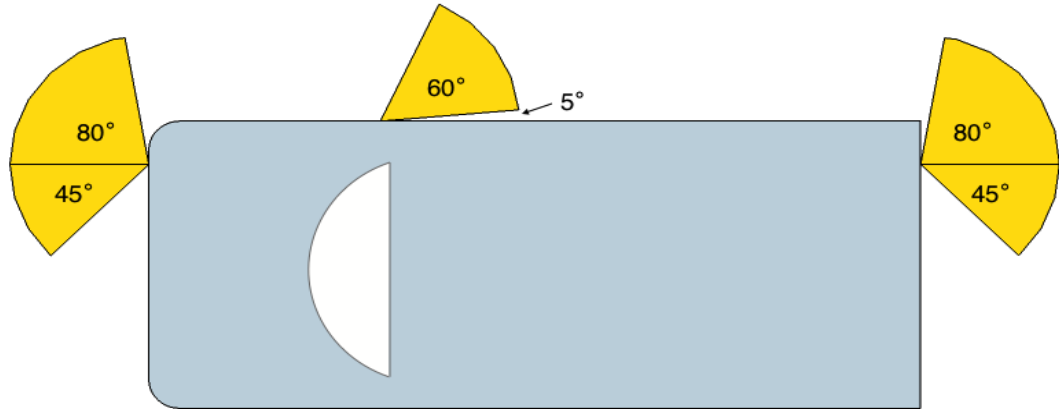

2.24.10 Direction indicators must flash at 90 ± 30 flashes per minute.

2.24.11 It must be possible to flash the left and right direction indicator lamps simultaneously, as a hazard warning signal.

2.25 Audible warning device

2.25.1 An audible warning device complying with the intent of UNECE Regulation 28 must be fitted to the solar car.

2.25.2 Sound pressure level must be more than $L_A = 105$ dB measured 2 m from the horn.

The horn should be mounted so that solar car occupants are not subjected to excessive sound pressure levels.

2.25.3 The device must emit a continuous and uniform sound.

2.26 Instrumentation

2.26.1 The following information must be provided to the driver at all times while driving:

- the speed of the solar car
- whether the direction indicators are operating
- whether the hazard lights are operating
- energy storage system warnings
- electronic rear vision images (if fitted).

2.26.2 This instrumentation must be powered from the energy storage system, and not from separate batteries.

2.27 Automatic functions

2.27.1 Any cruise control function must automatically deactivate when the brake is operated or the car is turned off.

- 2.27.2 Any automatic driving function must immediately deactivate on manual input or when the car is turned off.

2.28 Electrical safety

Electrical safety requirements are based on Section 5 of UNECE Regulation 100. The term 'high voltage' means more than 60 V dc or more than 30 V rms ac.

- 2.28.1 Protection against direct contact with high-voltage parts, including conductors, must be achieved using double insulation, enclosures or barriers. It must not be possible to remove protection without the use of tools.
- 2.28.2 Protection against direct contact with high-voltage parts inside the driver, passenger and luggage compartments must be designed to exclude objects larger than 1 mm diameter (Ingress Protection rating IPXXD).
- 2.28.3 Protection against direct contact with high-voltage parts inside areas other than the driver, passenger and luggage compartments must be designed to exclude fingers (Ingress Protection rating IPXXB).
- 2.28.4 Double insulation must meet the AS 3001/IEEE 100 definition: comprising both basic insulation and supplementary insulation. A single layer of reinforced insulation is also acceptable. Electrical tape wrapped around an insulated wire is not acceptable—anything damaging the electrical tape is likely to damage the insulation too. The surfaces of a photovoltaic cell are deemed to be double-insulated if properly encapsulated.
- 2.28.5 High-voltage energy storage packs must be marked with the high-voltage symbol shown in the following diagram.



- 2.28.6 The high-voltage symbol must also be visible on any enclosure or barrier that can be accessed without using tools, if removing the enclosure or barrier exposes high-voltage parts.
- 2.28.7 The resistance between any exposed conductive part and each terminal of the energy storage system must exceed $100 V$ ohms, where V is the nominal voltage of the energy storage system.
- This is equivalent to a maximum leakage current of 10 mA.*
- 2.28.8 The resistance between any exposed conductive part and each terminal of every solar cell must exceed $100 V$ ohms, where V is the maximum circuit voltage of the solar collector.
- 2.28.9 Exposed carbon fibre is considered to be an exposed conductive part and so must be isolated from the energy storage system and from the solar collector.

2.28.10 Each energy storage pack must be protected by a fuse or circuit-breaker rated to interrupt the short-circuit fault current of the pack. This fuse or circuit-breaker must be mounted in or on the energy storage pack.

2.29 Electrical safe state

2.29.1 The solar car must have a 'safe state' which minimises the risk of electrical fire and electric shock to occupants, team members, emergency response personnel, and bystanders. When in the safe state:

- there must not be a high voltage across any pair of conductors emerging from energy storage packs or from the solar collector
- every conductor emerging from each energy storage pack must be galvanically isolated from every energy storage cell
- low voltage must not be present across any pair of conductors emerging from energy storage packs or the solar collector unless the pair of conductors is incapable of delivering more than 50 mA of current.

2.29.2 Any conductor that is more than 200 mm from the nearest PV cell or from an associated electronics module such as a maximum power point tracker is considered to be outside of the solar collector.

2.29.3 All mechanisms for placing the solar car into safe state and maintaining safe state must employ mechanical switches or 'normally open' contactors designed to be fail-safe; if an electrical activation mechanism fails, the solar car must automatically and immediately place itself into safe state, and must remain in safe state indefinitely.

2.29.4 The driver must be able to place the solar car into safe state while seated in the normal driving position and without releasing the safety-belt.

2.29.5 For emergency use, an activation device that immediately places the solar car into safe state must be provided on the exterior of the car. The activation device must be placed within a yellow disc with a minimum diameter of 180 mm. Also in the yellow disc must be a blue equilateral triangle (minimum side length 150 mm) that contains a red flash, with the legend Emergency Electrical Isolation. In addition, there must be a clear instruction on how to operate the device (e.g., PULL or PRESS). The yellow isolation disc and the activation mechanism must be clearly visible to an emergency services first responder approaching the driver, and must be within 100 mm of the base of that part of the windscreen used to meet the forward vision requirement, and adjacent to the driver egress opening.



3 The Adventure

3.1 Supervision

- 3.1.1 The Clerk of the Course is responsible for supervising on-road activities.
- 3.1.2 Communication with the Clerk of the Course may be made through deputies and assistants (Red-Shirts) and other senior officials.

3.2 Safety

- 3.2.1 The team manager must appoint a safety officer to be responsible for the general safety of the team (see also Regulation 1.19.3).
- 3.2.2 The team manager must appoint a battery officer to be responsible for the safe operation of batteries and for supervising response to any battery emergency (see also Regulation 1.19.3).
- 3.2.3 Battery incident response kits must be readily available to the solar car and any other vehicle carrying solar car batteries.
- 3.2.4 Each team must have at least one member holding a recognised first-aid certificate, current for the duration of the event. This person must travel in the front or rear escort vehicle.
- 3.2.5 It is the responsibility of each team to ensure that the vehicles under their control are maintained in a safe, roadworthy condition and are operated safely and within the law at all times.
- 3.2.6 All solar cars and escort vehicles are operated and driven at the team's own risk.
- 3.2.7 The Clerk of the Course may exclude any team from the event at any time if any team member operates a solar car or any other vehicle in an unsafe manner.
- 3.2.8 Teams must look after the health and safety of their team members.

Fatigue and dehydration are serious hazards in this event. This is especially relevant to drivers, particularly those of solar cars.

- 3.2.9 Drivers, team members, officials and observers are to be drug free and maintain a blood alcohol level less than 0.01% whilst engaged in any duties associated with the event.

3.3 Safety-belts

- 3.3.1 The use of safety-belts is mandatory for all occupants of motor vehicles in Australia, including solar cars.

3.4 Helmets

- 3.4.1 Each occupant of a solar car must wear an approved motorcycle helmet securely fitted and fastened in accordance with the manufacturer's instructions.
- 3.4.2 An approved motorcycle helmet must have a mark certifying compliance with at least one of the following standards:
- Australian/New Zealand Standard AS/NZS 1698:2006
 - United Nations Economic Commission for Europe Regulation No 22 (UNECE 22.05)
 - an equivalent JIS or DOT standard.
- 3.4.3 Helmets must not be modified, have unauthorised attachments or be used in any way contrary to the manufacturer's instructions.

3.5 Safety equipment

- 3.5.1 Suitable and appropriate safety equipment must be carried at all times. The minimum safety equipment that must be carried in the rear escort vehicle is:
- a first-aid kit
 - safety glasses and gloves for handling batteries
 - at least two hazard warning cones
 - two yellow warning flags, minimum size 300 mm x 300 mm
 - suitable fire extinguishers
 - fire blankets
 - sand (or similar material) for extinguishing fires
 - a spade
 - suitable containers for damaged electrochemical cells
 - safety vests
 - two whistles.

3.6 Support vehicles

- 3.6.1 Each team must supply a front and a rear escort vehicle, a means of transporting the solar car, and sufficient additional vehicles to transport and support the team and its equipment during the event.
- 3.6.2 The minimum requirement for transporting the solar car is a suitable truck or trailer, which must accompany the team throughout the journey.

Many vehicle rental companies in Australia require the hirer and all drivers to be at least 23 years of age. One-way interstate rentals may not be possible. Trailers, in particular, should be booked early.

- 3.6.3 Each solar car must, at all times when in motion on the route, be accompanied by two escort vehicles—one immediately in front of the solar car and one immediately behind the solar car.

- 3.6.4 A minimum of two drivers must be available for every vehicle associated with the team.
- 3.6.5 The rear escort vehicle must not be a bus, truck or large campervan, or be towing a trailer.

If traffic approaching from behind sees a large vehicle with a flashing light, the immediate perception is that that vehicle itself is the hazard, not the solar car it is escorting. This may lead to a member of the public overtaking a large rear escort vehicle only to encounter an unexpected and previously unseen solar car.

3.7 Escort vehicle signage

- 3.7.1 All team vehicles must carry a sign, visible from 30 m to the rear, stating the name and team number of the team to which they belong.
- 3.7.2 All team vehicles equipped with Citizen's Band (CB) radio must carry a sign, visible from 30 m to the rear, advising the CB channel number in use.
- 3.7.3 A warning sign larger than 900 mm x 300 mm with black lettering on a yellow background, clearly visible from a distance of 30 m, must be displayed on the rear of the rear escort vehicle, stating

CAUTION: SOLAR VEHICLE AHEAD

- 3.7.4 No vehicle other than the rear escort vehicle may carry such a sign.
- 3.7.5 Front and rear escort vehicles must be fitted with amber flashing lights visible from all directions at a distance of at least 200 m in daylight. Flashing amber lights must not be obscured by signs or other equipment on the roof of an escort vehicle.

Beacons designed as warning devices for industrial equipment are unlikely to meet the visibility requirement.

3.8 Communication

- 3.8.1 Every solar car must have means of two-way voice radio communication with its rear escort vehicle when driving.
- 3.8.2 Each team must carry a satellite telephone, and notify the event organiser of its number. This notification will be required at registration. An external antenna is usually required when using a satellite telephone in a vehicle.
- 3.8.3 The front and rear escort vehicles (at least) for each solar car must each have a UHF CB radio compliant with [Australian regulations](#). Teams must monitor the channel they have been allocated at all times while on the road, and respond promptly and courteously to reasonable communications with other road users, teams and officials.

3.9 Heavy vehicles

- 3.9.1 Any team operating or contracting a vehicle over 3 tonnes GVM or a passenger vehicle with 12 or more seats must register the full details with the event organiser.
- 3.9.2 Compliance with Australian National Heavy Vehicle regulations concerning [driving hours, record keeping and fatigue management](#) is mandatory.

3.10 Preparation and testing

- 3.10.1 The event organiser will work with the relevant authorities to provide on-road testing facilities. Detailed arrangements will be published in the Team Manager's Guide.

Teams who make direct contact with Australian road authorities delay this process.

- 3.10.2 Any team driving a solar car on a public road without a permit is liable to civil penalties and exclusion from the event.
- 3.10.3 The event organiser will provide facilities for team preparation and track testing of solar cars at the Hidden Valley Raceway in accordance with the dates listed in the schedule.
- 3.10.4 [Australian workplace standards](#) will apply to all event-related activities in Australia.
- 3.10.5 The event organiser will appoint a paddock manager and a track controller to supervise the preparation and test facility. The directions of the paddock manager must be followed.
- 3.10.6 No test driving is to be conducted in the paddock, car park or access roads.
- 3.10.7 The track must not be accessed without clearance from the track controller.
- 3.10.8 The Clerk of the Course may impose event penalties for breaches of speed limits or other rules at the Hidden Valley Motor Sports Complex.
- 3.10.9 The event organiser reserves the right to request a security deposit against damage, rubbish removal or cleaning beyond reasonable expectations.
- 3.10.10 Teams electing to prepare their vehicles in other locations will be provided with temporary pit facilities to assist their attendance at dynamic scrutineering.

3.11 Team registration and scrutineering

- 3.11.1 All participants are required to attend with their team to complete the registration process, and present their solar car for the scrutineering process. The scrutineering process is divided into static and dynamic operations.
- 3.11.2 Team registration and static scrutineering will take place at the Darwin Convention Centre or such other place as determined by the event organiser at the time and date described in the schedule.
- 3.11.3 Teams must attend registration and static scrutineering with:

- the team manager, and an interpreter if required
- all solar car drivers, with their driving licences and their driver training log books
- any waiver documents required for participants under the age of 18
- all solar car passengers
- the team safety officer
- the team battery officer
- the solar car, in road-ready condition
- front and rear escort vehicles, including any trailer that may be attached to the front escort vehicle, in road-ready condition
- the solar car trailer or solar car transport truck they intend to use in the event
- for Cruiser class teams, any external charger to be used to charge the energy storage system during the event
- tools and personnel required to facilitate inspection of the solar car
- a list of all vehicles associated with the team, including make, model, colour and registration number
- Group D compulsory documentation
- a spare solar car tyre of each type
- a sample energy storage cell (if cells inside the energy storage packs are not clearly visible)
- the lockable box in which energy storage packs can be impounded where required.

3.11.4 Solar cars must be transported to scrutineering on the solar car trailer or truck that will be used during the event.

3.11.5 The team manager must attend all registration and scrutineering stations. A team manager not proficient in English must provide an interpreter to accompany them at all times during this process.

3.11.6 All team members must complete their online registration by signing in at registration.

3.12 Static scrutineering

3.12.1 Static scrutineering will check for compliance with the regulations, and will include a regulatory compliance and roadworthiness inspection by the Northern Territory road transport authority.

3.12.2 Qualification must be achieved in road-ready condition. Teams' unable to present at the designated time in road-ready condition may fail to qualify.

3.12.3 Up to seven members of a team (including an interpreter and any team media personnel) may accompany the solar car on the scrutineering floor. Team members may be substituted between inspection stations.

3.12.4 Some dismantling (such as removal of the solar collector or top shell) may be required to facilitate inspection of the following components:

- mechanical systems (including seats, tyres, brakes and steering)
- electrical systems
- energy storage system.

- 3.12.5 Dismantling and reassembly of the solar car when required to facilitate inspection of the solar car must be conducted (in the sole opinion of the Chief Scrutineer) in a reasonable time.
- 3.12.6 Checks and inspections with the solar car in a road-ready configuration will include, but not be limited to:
- signage
 - dimensions
 - solar collector type and size
 - egress—all solar car drivers and passengers are required
 - vision—all solar car drivers are required
 - lights, indicators and horn
 - electrical compliance.
- 3.12.7 All energy storage devices must be declared at static scrutineering. Failure to declare any energy storage device may lead to disqualification.
- 3.12.8 The mass of each solar car driver or passenger, with helmet and driving clothes, will be determined at scrutineering. If the mass of a driver or passenger is less than 80kg, ballast provided by the event organiser will be added to make up the difference. No credit will be given if a driver or passenger weighs more than 80kg.
- Deliberate consumption of excessive food and drink prior to weigh-in is not in keeping with the spirit of the event and may be hazardous to the health of the individual.*
- 3.12.9 Drivers and passengers may be weighed at any time during the event. Changes in weight considered unreasonable by the Chief Medical Officer will be referred to the Clerk of the Course.
- 3.12.10 Non-compliance penalties may be imposed at the absolute discretion of the Chief Scrutineer, and may include failure to qualify.

3.13 Dynamic scrutineering

- 3.13.1 Dynamic scrutineering exercises will test the speed, stability and braking capability of the solar car.
- 3.13.2 Dynamic scrutineering will be held at the Hidden Valley Motor Sports Complex, or such other place as determined by the event organiser, on Saturday 7 October 2017. Attendance of team managers and drivers at 0700 roll call is mandatory.
- 3.13.3 No solar car may be submitted for dynamic scrutineering without having first passed static scrutineering.
- 3.13.4 Solar cars must complete dynamic scrutineering in road-ready condition and with occupant ballast in place.
- 3.13.5 Cruiser class solar cars must complete dynamic scrutineering with all seats occupied.

3.13.6 No solar car will be given permission to start the event until it has passed dynamic scrutineering. Any solar car failing dynamic scrutineering will only be permitted to re-present at the absolute discretion of the Chief Scrutineer. Dynamic scrutineering will close at 12:30 on Saturday 7 October 2017.

3.14 Modifications or changes after scrutineering

3.14.1 Once a solar car and its drivers have passed static scrutineering, no changes to the design or configuration of the solar car (that is, to any items described in the compulsory documentation) or changes to drivers will be permitted.

3.14.2 Once a solar car has passed dynamic scrutineering, no component exchange, modification or repair of the solar car is permitted without the approval of the Chief Scrutineer until after the official start.

3.15 Briefings

3.15.1 A compulsory team manager meeting will be held in Darwin on Monday 2 October 2017 at a time and place to be advised. This briefing is for team managers only. Team managers not proficient in English must be accompanied by an interpreter.

3.15.2 A compulsory safety and procedural briefing will be held on Saturday 7 October 2017. All team members must attend.

3.16 Observers

3.16.1 The Clerk of the Course will appoint an observer to travel with each team. Observers may be changed between teams at any time during the event.

3.16.2 The observer's responsibilities are:

- to record the locations and times that teams start and stop
- to record the locations and times of all activities and incidents that may affect the outcome of the event
- to record the number of Cruiser occupants travelling between control stops
- to record whenever a Cruiser team charges from an external source
- to check that any ballast is correct and properly stowed following each driver or passenger change
- to be satisfied that the energy storage system cannot be charged or interfered with between sunset and sunrise, except as allowed for Cruiser class solar cars
- to notify the Clerk of the Course at the earliest opportunity if any breach of regulation is suspected, energy storage cells or modules have been changed or an energy storage system seal broken, or if they have any concerns about the actions of the team.

3.16.3 Observers are not permitted to interpret regulations or give advice to teams.

3.16.4 Each team's responsibilities to the observer are:

- to assist the observer in their duties at all times
- to provide reasonable food for the observer at least three times a day, and such drinking water as the observer may require
- if requested by the observer, to send for assistance from the event organiser or transmit information to Mission Control
- to provide a proper seat in the rear escort vehicle
- to provide space for the observer's luggage in the rear escort vehicle
- to not make any demands of the observer to assist team operations.

3.16.5 Each team must allocate the front passenger seat of the rear escort vehicle to the observer. This includes fair and reasonable space with, for example, the foot well not being filled with computer equipment such that the passenger space is restricted.

3.17 Start line and grid

3.17.1 The ceremonial start of the event will be held in State Square, Darwin, from 08:15 on Sunday 8 October 2017, or such other place and time as the Clerk of the Course may direct.

3.17.2 Starting position will be determined by class and performance during dynamic scrutineering.

3.17.3 The detailed procedural instructions (to be issued in Darwin), will be part of these regulations.

3.17.4 All solar cars must be in their starting grid position by the appointed time for final inspections. Any solar car not present will have their start time amended.

3.17.5 Teams must not work on their solar cars on the start grid.

3.17.6 Two team members must stay with the solar car on the start grid to assist officials with final inspections.

3.17.7 Front and rear escort vehicles must be in their designated places by 08:00.

3.17.8 Escort vehicles must be in position with the solar car before entering public roads. Solar cars which have left the start line and whose escort vehicles are not able or not ready to merge will be directed to return to the start area.

Team managers should recognise that it is not a realistic expectation for escort vehicle crew members to witness the start and re-join their vehicles to make a timely departure.

3.18 Energy collection

3.18.1 Charging the energy storage system or powering the solar car from an unauthorised source will lead to exclusion from the event.

3.18.2 Cruiser class solar cars may recharge from external sources at any time except during control stop time. The recharge energy will contribute to the energy efficiency score.

- 3.18.3 External devices intended to increase the irradiance on the solar collector or increase the efficiency of the solar collector must not be used at any time. Ground sheets used when charging must not increase the irradiance on the solar collector.

Spraying of water from external sources is no longer allowed

- 3.18.4 From the official start of the on-road component of the event until finish or withdrawal, the energy storage system must never be removed from the observer's control.
- 3.18.5 Damaged energy storage cells may be bypassed, but must not be removed from the energy storage system unless it would be unsafe to leave them in. Cells removed must be replaced by ballast with mass greater than the mass of the removed cells. If a solar car is unable to continue because too many cells have been damaged, the team may, with the event organiser's permission, replace cells and continue the event in Adventure class.

3.19 Route

- 3.19.1 The event course will be the major highways between Darwin, Northern Territory, and Adelaide, South Australia—a distance of approximately 3000 km.
- 3.19.2 One printed copy of the official route notes will be provided to each registered team. Additional copies will be available for download from the 2017 Bridgestone World Solar Challenge website from September 2017.
- 3.19.3 Mandatory control stops will be established along the route. The locations of the control stops will be published in the official route notes.
- 3.19.4 Any detour signs erected by the civil authorities must be observed and the correct route re-joined at the first opportunity.
- 3.19.5 The event organiser may change the course at any time.

3.20 Timing

- 3.20.1 The official start time on Day 1 will be 08:30 for all teams.
- 3.20.2 The official start time each day after Day 1 is 08:00. The official finish time each day is 17:00.
- 3.20.3 A time penalty of one minute will be imposed for each minute taken past the official finish time, up to and including 10 minutes past the official finish time. Beyond 10 minutes, each additional minute will attract a penalty of two minutes. Time penalties incurred in this manner will determine an adjustment of the official start time the following day.

Example: If a team finishes at 17:07 on Day 2, the official start time for Day 3 will be adjusted to 08:07. If a team finishes at 17:13 on Day 2, the official start time for Day 3 will be adjusted by $1 \times 10 + 2 \times 3$ minutes to 08:16.

- 3.20.4 A solar car starting before its official start time will be subject to a penalty of 2 minutes for each offending minute.

3.21 Tracking

- 3.21.1 Each solar car must carry a data logging and tracking device provided by the event organiser. The specifications of the tracking device are described in Regulation 2.9
- 3.21.2 Information concerning progress and operation of solar cars may be publicised during the event.
- 3.21.3 Satellite tracking data will not be accepted as basis for inter-team protests.

3.22 Solar car drivers and passengers

- 3.22.1 Only registered solar car drivers may drive the solar car during event hours.
- 3.22.2 When driving, ballast must be carried in accordance with the provisions of Regulation 2.8.

3.23 Driving conduct

- 3.23.1 Each team must ensure that all vehicles associated with their attendance at the event are driven in a careful and courteous manner at all times.
- 3.23.2 Overtaking must be done in a safe manner and take into account prevailing conditions.

A team seeking to overtake another team should communicate with the other team via radio, and both teams should maintain communication throughout the manoeuvre.

- 3.23.3 The organiser reserves the right to determine if any individual is acting de facto as a part of a team.
- 3.23.4 The front and rear escort vehicles must have their amber flashing lights operating whenever they are escorting the solar car. Support vehicles must not have amber flashing lights operating if they are not (directly) escorting the solar car.
- 3.23.5 Except when pushing a disabled solar car to a place of safety, solar cars must not be pushed along the road. Push starting the solar car is not allowed.
- 3.23.6 Whilst travelling on the open road, the front escort vehicle must be within 500 m of the solar car. The solar car must be allowed a safe stopping distance appropriate to the speed and conditions prevailing.
- 3.23.7 Whilst travelling on the open road, the rear escort vehicle must be within 5 seconds of the solar car, and must at all times maintain a safe stopping distance appropriate to the speed and conditions prevailing.
- 3.23.8 Solar cars must not be driven on any public road between sunset and sunrise.
- 3.23.9 Teams must comply with any requirements imposed by road traffic authorities, police, or event officials.
- 3.23.10 Solar cars, escort vehicles and other team vehicles may be subject to scrutineering at any time during the event to ensure compliance with the regulations.

3.24 Stopping

- 3.24.1 No team vehicle may stop on the road except in an emergency or when required by traffic conditions.

Stopping on the road so that you can lift your car off the road is dangerous, and will attract a penalty determined by the Clerk of the Course.

- 3.24.2 When stopped adjacent to a road, all wheels of all vehicles must be clear of the road.
- 3.24.3 Wherever possible, vehicles must be parked, and all team activity must occur, at least 10 m from the edge of the road.
- 3.24.4 Where any activity takes place less than 2 m from the road, two team members must be positioned in a place of safety to warn approaching traffic using yellow flags, and to warn the team of approaching traffic using a whistle.

3.25 Obstructing other road users

- 3.25.1 Vehicles associated with a team must not obstruct other road users, including other teams. Infringement of this regulation will incur a penalty for each incident.
- 3.25.2 To avoid obstructing other road users, each driver of a team vehicle other than the solar car and front and rear escort vehicles must leave at least 200 metres of space in front of their vehicle so that other road users can overtake and occupy the space in front of them. If it is safe to do so and will help clear traffic building up behind a vehicle, drivers of team support vehicles should pull off the road to allow other road users to pass.

3.26 Control stops

- 3.26.1 Solar cars must stop for 30 minutes at designated control stops along the route. The locations of the control stops will be specified in the official route notes provided by the event organiser.
- 3.26.2 All vehicles must obey control stop speed limits.
- 3.26.3 Teams must obey all directions given by the control stop manager.
- 3.26.4 Once all occupants are out of the car, the arriving driver, alone, may reconfigure the car for charging before control stop timing commences.
- 3.26.5 Control stop timing commences when the arriving driver activates the control stop timing system.
- 3.26.6 No team member, including the driver, may touch the solar car during the 30 minutes of the control stop. The solar car may reconfigure itself.

The control stop manager may reset the remaining time to 30 minutes if team members interfere with the solar car during the 30-minute control stop period.

- 3.26.7 (Teams may not spray water on the solar collector during the ... control stop) is redundant – see 3.18.3

- 3.26.8 Control stop timing concludes when the departing driver deactivates the control stop timing system.
- 3.26.9 The departing driver, alone, may (after deactivating the control stop timing system) reconfigure the car for driving.
- 3.26.10 The departing car will not be allowed to leave until the observer has confirmed that the ballast and drinking water is in place, the seat belt is fastened, the helmet is secured and the solar car is ready for the road.

3.27 Overnight stops

- 3.27.1 An overnight stop commences when the team stops driving for the day, and finishes when the team starts driving the next day.
- 3.27.2 The selection (and any cost) of overnight stop locations is the responsibility of each team.
- 3.27.3 At overnight stops, the solar car and all other vehicles must be parked in such a manner that they, and all team activities, are conducted at least 10 metres from the edge of any road.
- 3.27.4 If a team's overnight camp is not immediately adjacent to the road, a marker cone must be placed on the roadside adjacent to the point the team exited the official route.
- 3.27.5 The observer, with the team manager, must place a mark on the road to indicate the position at which the solar car stopped. The mark will be the starting line for the following morning.
- 3.27.6 The solar car must be driven, pushed by hand or carried by hand between the stopping location and its solar charging location.
- 3.27.7 There are no restrictions on the number of team members used to reconfigure the solar collector for charging at overnight stops.
- 3.27.8 At sunset, Challenger teams must either:
- remove energy storage packs from their solar car and place them in the lockable box in a position acceptable to the observer, or
 - close the car with the energy storage system inside and cease all work on the car.
- 3.27.9 Cruiser teams may elect to charge their energy storage system from an external source supplied or arranged by the team. The team manager must tell the observer that they will be charging, and the observer will record in the log book that the team had recharged.
- 3.27.10 If a Cruiser team elects to not charge from an external source overnight then the team must either:
- remove all energy storage packs from their solar car and place them in the lockable box in a position acceptable to the observer, or
 - close the car with the energy storage system inside and cease all work on the car.

3.27.11 Teams will be given access to their energy storage packs 15 minutes before sunrise.

3.28 This regulation (water spraying) has been removed – see 3.18.3

3.29 Trailering

The term 'trailing' applies to any means of transport used to carry the solar car.

3.29.1 Teams unable to maintain a minimum speed of 60 km/h on the open road or unable to drive to the next control stop before it closes must stop and transport their solar car forward to the next open control stop to get further instructions from the Clerk of the Course.

3.29.2 The Clerk of the Course may allow the team to continue in the (non-competitive) Adventure class.

3.29.3 The solar car must be in safe state at all times while being transported.

3.30 Withdrawal

3.30.1 A team may withdraw by forwarding a completed withdrawal form (available from the observer) to the Clerk of the Course. The solar car may be transported to Adelaide to take part in the displays and the awards ceremony.

3.31 Penalties

3.31.1 The Clerk of the Course may impose demerit points on any team that breaches a regulation.

3.31.2 Each demerit point given to a Challenger team will also incur a time penalty of 30 minutes, to be served at a control stop nominated by the Clerk of the Course. All Challenger time penalties must be served before arriving at the finish line.

3.31.3 Each demerit point given to a Cruiser team will also reduce the team's relative energy efficiency score (E/E^*) by 0.0125.

3.31.4 A team accruing three or more demerit points will be excluded from the remainder of the event.

3.31.5 The Clerk of the Course may impose operational restrictions (such as speed restrictions) on any team.

3.31.6 At any time during the event, the Clerk of the Course may issue a penalty of one demerit point in response to any of the following behaviours noted by an observer or reported by an official:

- obstructing other road users
- stopping on the road (other than when required by traffic conditions)
- poor safety protocols (e.g., safety flags, whistles etc.)

- overnight activities too close to the road
- driving without both front and rear escort vehicles
- escort vehicles driving without visible flashing lights
- driving without effective rear vision.

3.31.7 The Clerk of the Course will determine penalties for offences including:

- slip streaming or pressure wave pushing
- failure to follow the route instructions
- failure to observe a request by police or event officials
- wilful damage or interference to property
- failure to stop at a designated control stop
- exceeding any posted speed limit
- driving at less than 50 km/h in areas with a speed limit of 100 km/h or greater, when not constrained by traffic
- driving without adequate visibility, due to smoke, dust or rain.

3.31.8 The Clerk of the Course may exclude any team from the event for wilful disregard of any regulation or of the spirit of the event. These offences include but are not limited to:

- misrepresentation
- wilful obstruction, or aggressive or unsafe driving
- replacement of energy storage cells
- charging of the energy storage system from any unapproved source
- driving the solar car without a rear escort vehicle
- accumulation of three or more demerit points.

3.32 Protests and appeals

3.32.1 A written protest may be lodged with the Clerk of the Course, within 12 hours of the incident giving rise thereto. A protest fee of AU\$200 will apply.

3.32.2 Any decision of the Clerk of the Course may be appealed to the Stewards of the event by lodgement of a written Notice of Appeal that details the grounds for the appeal, within one hour of the notification of the decision giving rise thereto. An appeal fee of AU\$500 will apply.

Protests, appeals and fees should be forwarded to the Clerk of the Course via any Red-Shirt official.

3.32.3 The Chief Steward is empowered to convene a tribunal to consider any protest or appeal requiring final resolution. The tribunal may take advice from any party. The decision of the tribunal is final and binding.

4 Achievement and celebration

4.1 Provisional results

- 4.1.1 Results published throughout the duration of the event are provisional. Results will not be final until after the determination of any of outstanding protests and appeals.

4.2 Completing the course

- 4.2.1 To complete the course, the solar car must reach the finish line by the designated route, in accordance with the regulations.
- 4.2.2 A marshalling point will be established, approximately 1 km from the finish line. The finish time for the journey will be determined at the marshalling point.
- 4.2.3 Teams must leave their support vehicles at the marshalling point. The solar car must drive to the finish line, escorted by vehicles provided by the organiser.

In practice, the lead escort vehicle will be the organiser's bus, which will carry the team members to the finish line. Support vehicles must be moved from the marshalling point on the day of arrival. The organiser will provide long term parking at another location.

4.3 Challenger class

- 4.3.1 The goal for the Challenger class is to be the first to arrive at the Adelaide marshalling point.
- 4.3.2 We do not want traffic in Adelaide to change the finish order of teams. An urban area reference point will be established at the start of the Adelaide urban area. The location will be published in the official route notes. If a team A is able to keep up with traffic and is overtaken by another team B after the urban area reference point, the arrival time of team B at the marshalling point will be adjusted to be one minute behind the arrival time of team A. If team A is overtaken by team B and team A is unable to keep up with traffic at any point after the urban area reference point, the arrival time of team B will not be adjusted.
- 4.3.3 Any unserved time penalties must be served at the marshalling point.
- 4.3.4 The Challenger Cup will be awarded to the Challenger team that completes the route with the earliest finish time (arrival time at the Adelaide marshalling point plus any unserved penalty time).
- 4.3.5 Challenger teams that complete the route will be ranked by finish time (arrival time at the Adelaide marshalling point plus any unserved penalty time).
- 4.3.6 Challenger teams that do not complete the route will be ranked behind Challenger teams that complete the route. They will be ranked by the number of control stops completed in Challenger class (more is better), and within these groups by arrival time at the last

control stop completed in Challenger class, plus unserved time penalties accrued at any time during the event.

4.4 Cruiser class

4.4.1 The goal for Cruiser teams is to transport people from Darwin to Adelaide and arrive in Adelaide within a specified time window. For the 2017 Bridgestone World Solar Challenge, teams must arrive at the Adelaide marshalling point between 11:00 and 14:00 (ACST) on Day 6 (Friday).

4.4.2 Cruiser teams will be scored on energy efficiency and practicality.

4.4.3 The Cruiser Cup will be awarded to the Cruiser team that completes the route, arrives in Adelaide within the target time window, and has the highest score, S , according to the calculation

$$S = 80 E/E^* + 20 P/P^*$$

where E is the team's energy efficiency score, E^* is the highest energy efficiency score of any Cruiser team, P is the team's practicality score, and P^* is the highest practicality score of any team that completed the route and arrived at the Adelaide marshalling area within the target time window.

4.4.4 Cruiser teams that complete the route and arrive at the Adelaide marshalling point within the target time window will be ranked by score (highest is best).

4.4.5 Cruiser class teams arriving at the Adelaide marshalling point before the target time window will not have their arrival time recognised. No Cruiser class team will be allowed to proceed to the finish line until the commencement of the target time window.

4.4.6 Cruiser teams that do not complete the route or that arrive at the Adelaide marshalling point after the target time window will not be ranked.

4.4.7 Cruiser teams completing the route and arriving at the Adelaide marshalling area before or within the target time window will have their energy efficiency calculated as:

$$\text{energy efficiency} = \text{person-kilometre distance} / \text{nominal external energy use.}$$

4.4.8 Nominal external energy use of a Cruiser solar car will be calculated as $(n + 1) Q$, where n is the number of times the energy storage system is charged from external sources between the start line and the finish line, and Q is the nominal energy capacity of the energy storage system. The nominal energy capacity of a rechargeable electrochemical battery is the sum of the nominal cell masses in kilograms multiplied by:

- 330 Wh kg⁻¹ for Li-S cells
- 250 Wh kg⁻¹ for Li-ion cells
- 250 Wh kg⁻¹ for Li-polymer cells
- 125 Wh kg⁻¹ for LiFePO₄ cells.

- 4.4.9 The nominal energy capacity of other types of energy storage system will be determined by the Chief Energy Scientist.
- 4.4.10 Person-kilometre distance is the sum of the distances travelled by drivers and passengers in the solar car between the start line and the finish line. Person-kilometres will be counted for each seat that is occupied for a complete leg between consecutive control stops.
- 4.4.11 this regulation has been removed as it duplicated regulation 4.4.5
- 4.4.12 Cruiser teams that do not complete the route or that arrive at the Adelaide marshalling area after the target time window will be given an energy efficiency score of zero.
- 4.4.13 The practicality score for a Cruiser team will be determined by a panel of judges appointed by the organiser. Features that will contribute to the practicality score include:
- ease of access and egress
 - occupant space and comfort
 - ease of operation (driving and charging)
 - versatility
 - style
 - suitability for the declared purpose.

Judges will want to get into each Cruiser solar car and test the space and comfort. Cruiser solar cars that are difficult to get into will score poorly, which will reduce the overall score.

4.5 Adventure class

- 4.5.1 Adventure class is non-competitive.
- 4.5.2 The progress of Adventure class solar cars will be controlled by the Clerk of the Course.

Adventure class solar cars will be allowed to drive to the finish line only after the first four Challenger solar cars have done so.

- 4.5.3 Teams in Adventure class will not be ranked by performance.

4.6 Awards

- 4.6.1 An awards ceremony will be held in Adelaide on the evening of Sunday 15 October 2017.
- 4.6.2 Entry to the awards ceremony is by ticket only.

Each participating team will be provided with tickets commensurate with the number of registered individuals up to a maximum of 20 tickets. Additional tickets (subject to the capacity of the venue) may be purchased. Further details will be provided in the Team Manager's Guide.

- 4.6.3 The winner of the Challenger class will receive the Challenger Cup; the winner of the Cruiser class will receive the Cruiser Cup.
- 4.6.4 The winners of the Challenger and Cruiser classes will each be recognised as the holder of the World Solar Cup for their class achievement in the 2017 Bridgestone World Solar

Challenge. In addition to the Challenger Cup and the Cruiser Cup, each class winner will be presented with their own replica of the World Solar Cup.

4.6.5 Additional awards may be presented, including the following categories:

- a Safety Award presented to the team exhibiting safety awareness in theory and practice
- the 'David Fewchuk Spirit of the Event' award presented to an individual exhibiting the qualities promoted by the Bridgestone World Solar Challenge
- an Innovation Award presented to the team presenting a concept which, in the opinion of the Scientific Faculty, furthers the aims of the event.

4.6.6 The event organiser reserves the right not to present an award in any given category.

4.6.7 Each team will receive a participation award.

4.6.8 All winning teams must make themselves available for an official media call if required.

4.7 Pack-down facilities

4.7.1 Open-air facilities will be made available for repacking solar cars for shipment. All vehicles, containers and equipment must be removed by close of business Wednesday 18 October 2017. Any remaining items will be removed for storage at the entrant's expense.

Glossary

ACDT	Australian Central Daylight Time (UTC + 10.5 hours).
ACST	Australian Central Standard Time (UTC + 9.5 hours).
AS/NZS	Australian Standard / New Zealand Standard.
battery	Electrochemical cells wired in series or parallel and housed in a single container.
CB	Citizen's Band radio.
certifying engineer	A professional engineer engaged by a team to report on compliance with regulations and roadworthiness requirements.
Clerk of the Course	The person responsible for coordinating Dynamic Scrutineering and the on-road portion of the event.
DOT	United States Department of Transport.
Energy storage pack	A self-contained box containing components of the energy storage system, such as electrochemical cells and a battery management system.
energy storage system	The solar car subsystem used to store energy. It is typically a rechargeable electrochemical battery, but other types of energy storage system are possible.
entrant	The legal entity that completes the Participation Agreement and requests a place in the event for one or more teams. An entrant is typically a registered institution, organisation or commercial entity.
FAI	Federation Internationale de l'Automobile.
FMVSS	United States Federal Motor Vehicle Safety Standards.
GST	Australian Goods and Services Tax.
high voltage	More than 60 V dc or more than 30 V rms ac.
ISF	International Solarcar Federation.
Judge of Fact	A person recognised by the organiser as able to determine whether a particular event occurred (e.g., whether a team obstructed traffic).
participant	A person who has registered to participate in the event as a member of a team.
PV	Photovoltaic.

Red-Shirt	A senior event official (wearing a red shirt) responsible for overseeing the conduct of the event.
road-ready	Ready to drive on the road.
scrutineering	The process of checking the solar car and other team vehicles for compliance with the regulations.
SFI	The SFI Foundation issues standards for motor sports equipment.
solar collector	The solar car subsystem used to collect solar energy. It is typically an array of photovoltaic cells, with or without concentrators or reflectors, but other types of solar collector are possible.
Steward	An event official responsible for ensuring regulations are applied correctly and fairly.
team	A group of people registered by the entrant to participate in the event. An entrant may have more than one team participating in the event.
Team Manager	The person in charge of, and responsible for, the actions of a team.
UHF	Ultra High Frequency. Commonly refers to Australian two-way radio operating on the Citizens Band.
UNECE	United Nations Economic Commission for Europe, responsible for regulations for motor vehicles .
UTC	Coordinated Universal Time.
VIN	Vehicle Identification Number.