

The home of the turntable

THE VINYL ENGINE®

For more turntable manuals and setup information
please visit www.vinylengine.com

B·I·CTM Multiple Play Manual Turntables

Owner's Manual
Belt Drive  Models 980 and 960 | Made in U.S.A.



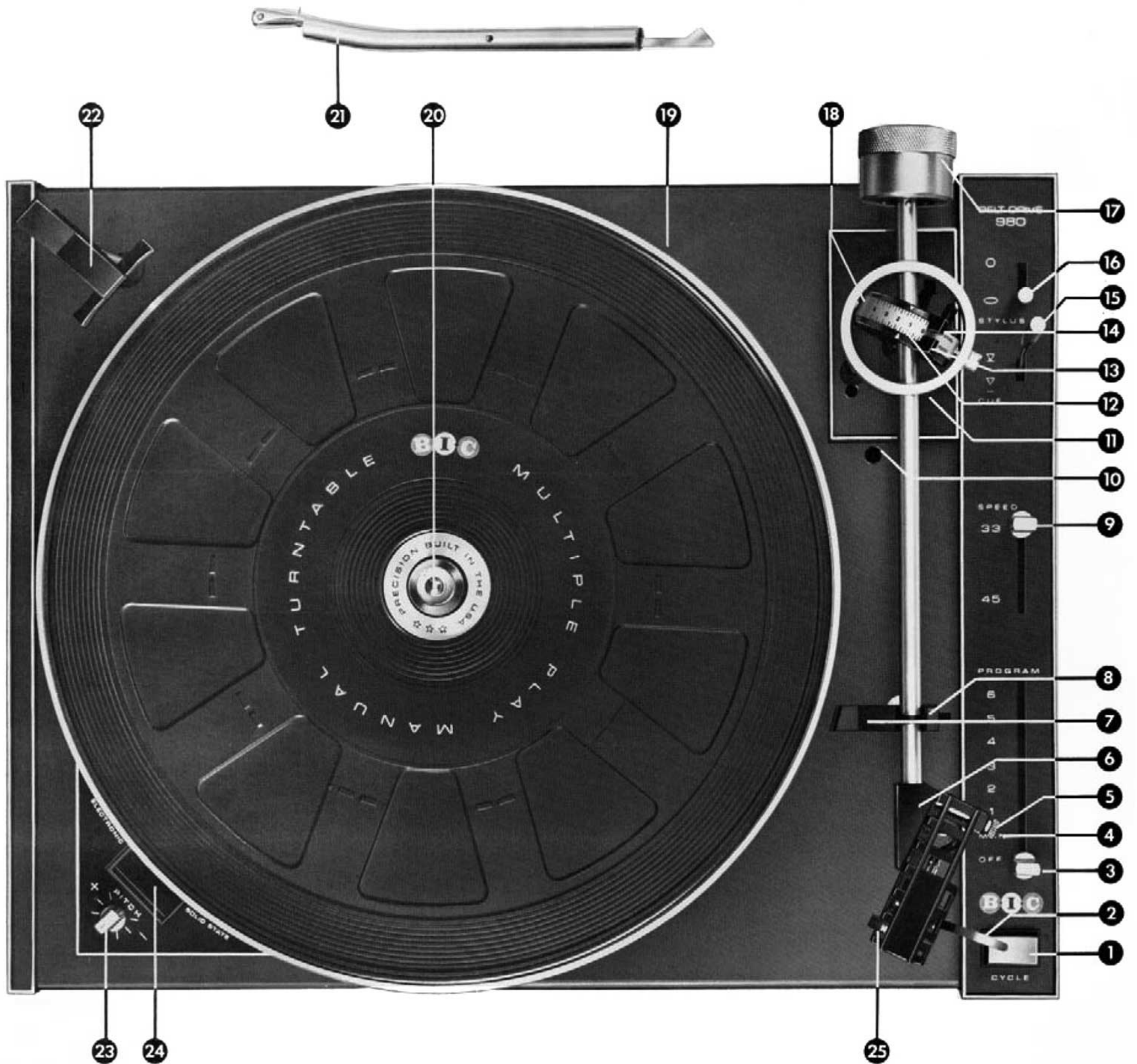

Features of Models 980 and 960 B·I·C Multiple Play Manual Turntables

1. Cycle button—feather touch control activates all turntable functions.
 2. Tone arm finger lift—human-engineered for positive, secure manual handling of tonearm.
 3. Programmer selector—selects manual or automatic operation, shut-off and number of plays.
 4. Initial 15 degree tracking angle adjustment—permits pivoting of entire shell for parallel alignment and 15 degree tracking angle of stylus assembly, regardless of shape or depth of cartridge.
 5. Knurled cartridge shell retaining nut—locks shell firmly in proper alignment.
 6. Cartridge shell connector—male/female connection for positive electrical contact.
 7. Tonearm rest—extended for stylus and cartridge protection.
 8. Tonearm lock—prevents damage during transport or accidental jarring.
 9. Speed selector—shifts drive belt for 33 $\frac{1}{3}$ rpm or 45 rpm rotation.
 10. Tonearm set-down adjustment—adjusts set-down position of stylus at edge of record.
 11. Cueing rate adjustment—varies cueing speed in accordance with user preference or to suit climatic conditions.
 12. Force calibration scale—expanded scale for precision setting of stylus tracking and anti-skate forces.
 13. Tracking force adjustment lever—sets desired tracking force from 0 to 4 grams.
 14. Anti-skate force adjustment lever—sets corresponding anti-skate force—may be set in tandem with tracking force adjustment or independently.
 15. Cueing lever—initiates safe, damped lowering or raising of tone arm or can be used as pause control.
 16. Stylus mode selector—selects proper skating force reference for elliptical or conical styli; eliminates the need for two calibration scales.
 17. Isolated tonearm counterweight permits dynamic zero balancing of entire tonearm, while insuring maximum damping.
 18. Precision gimbal bearings—for minimal horizontal and vertical pivotal friction.
 19. 12" diecast platter—solid, one-piece precision casting has computer optimized mass.
 20. Manual spindle—rotates with platter during single-play operation.
 21. Automatic spindle—supports records during automatic record play.
 22. Removable record support—platform stabilizes records placed on spindle for safe two-point support during automatic play
 23. Solid state electronic pitch control (Model 980 only)—sets precise, unvarying turntable speed and permits $\pm 3\%$ variation from nominal speed.
 24. Illuminated stroboscope (Model 980 only)—used in conjunction with electronic pitch control. Visible during record play.
 25. Auto/Manual cartridge angle selector—permits proper 15 degree compensation.
-
26. Elastomer suspension mounts—correlated to the mass of the turntable assembly for maximum isolation from external shock in all planes.
 27. All electronic drive signal generator (Model 980 only)—modular etched circuit generates stable 60 Hz. signal to drive synchronous motor.
 28. Synchronous 24 pole motor—operates at slow, vibration-free 300 rpm.

(26, 27 and 28 pertain to underside of unit not shown)

Index

Set-Up Procedures

Operating Procedures

There are many playing and operating options built into your B-I-C Multiple Play Manual Turntable, plus a number of unique control features. These are summarized on this page — and specific operating instructions for the various playing options are detailed on the pages indicated. Normal maintenance procedures are also described and listed, along with a set of specifications which will be of interest to the audio enthusiast.

	PAGE
How to properly unpack the unit	5
Note the accessories supplied	5
Installing the turntable on the base	5
Proper mounting of the cartridge in the tonearm shell	6
How to properly orient and position the cartridge	6
Connecting the shell with the tonearm	7
Installing the counterweight	7
Selecting proper stylus setting	7
Adjusting proper tracking and anti-skate forces	7
Leveling the cartridge shell	7
Installation of audio cable and ground connection	8
Connecting to AC power	8
<hr/>	
Manual play of a single record	9
Programmed repeat play of a single record	10
Automatic play of a single record	10
Automatic play of multiple records	10
Multiple play of records plus repeat of last record	11
Use of cueing and pause control	11
Adjusting the cueing rate	11
Adjustment of stylus set-down point	11
Turntable removal	12
Drive belt installation	12
Lubrication instructions	13
Tips on record care	13
Spare parts list	13
Accessories	13
General specifications	14
Trouble-shooting hints	15

Set-Up Procedure



Unpacking the Unit

Remove the unit from the bottom styrofoam filler by grasping the unit plate at the points indicated on the top cardboard packing piece. DO NOT lift the unit by grasping the tonearm. Whenever possible, the packing material should be retained in the event re-shipment is necessary. In any event, do not discard the packing material until all of the accessories described below are accounted for.

The top styrofoam filler contains the following:

1. A short manual spindle for playing single records.
2. A long automatic spindle for playing up to six records automatically.
3. Tonearm counterbalance weight.
4. A manual 45 rpm adaptor for playing large hole records, one at a time.
5. Cartridge mounting hardware; this contains the various screws that are needed for mounting the cartridge in the pickup head.
6. A combination gauge for setting stylus overhang and paralleling the stylus.
7. Transit wing nuts (2).
8. Extra lock nut.
9. Pick-up head.
10. Screwdriver
11. Removable record platform.

A small cardboard packing piece is installed in the right-hand pivot of the tonearm gimbal. MAKE CERTAIN THIS IS REMOVED, or the unit will not perform properly. Also, make certain that all rubber bands securing the line cord, audio cables, the tonearm tie, etc., are removed along with all other packing pieces.

Packing pieces are installed between the unit plate and turntable. They must also be removed and, if possible, should be retained as they are a very important part of the packing if the unit is ever shipped.

The audio cable is packed in a wedge on the right side of the unit.

Installing the Unit on the Base

Both the B-20 Base and WB-20 Base are supplied with a bottom safety cover which eliminates any possibility of mechanical hazard. Comprehensive installation instructions are included with each base. Prior to mounting upon a base, the audio cable *must be installed* on your B-I-C unit as per page 8 of this booklet.

PROPER INSTALLATION IS EXTREMELY IMPORTANT. DO NOT INSTALL THIS UNIT ON ANY DEVICE OTHER THAN THE OFFICIAL B-20 OR WB-20 BASES.



Cartridge Installation and Adjustment

In order to take advantage of the many features of the B-I-C tonearm, it is extremely important that the cartridge be properly installed and the various adjustments pertaining to the cartridge be made. These are described below:

Removal of the Plug-In Head

The B-I-C 980 and 960 employ a male/female connector (Fig. A), interlocked by a knurled nut. Because this system assures permanent, positive contact and withstands repeated use, it is the type of arrangement used on precision manual players.

Remove the pickup shell from the tonearm by turning the shell locking nut fully counter-clockwise until the nut is removed. **BE SURE NOT TO LOSE OR MISPLACE THE SHELL LOCKING NUT.** In the event this occurs an extra nut has been supplied. Pull the shell away from the tonearm horizontally, separating the male and female portions of the plug-in connector.

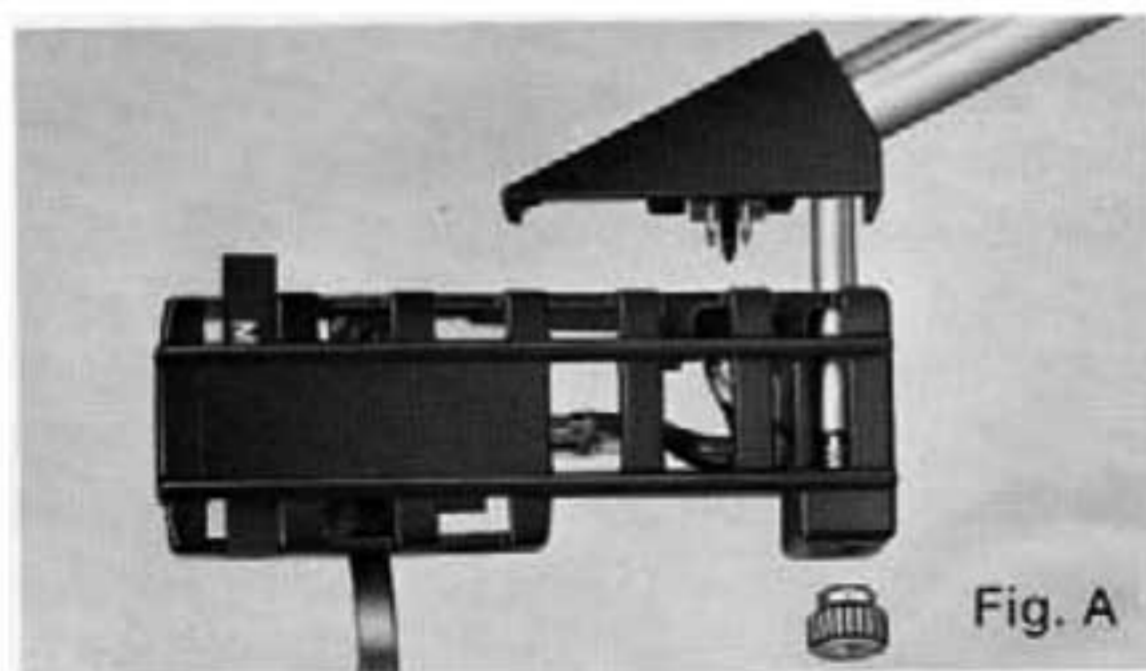

Mounting Cartridge in Head

The B-I-C 980 and 960 are supplied with three sets of varied length cartridge mounting screws. It is important that the mounting screws used are not too long or they will pass through the *shell mounting bracket*. In most cases the mounting screws supplied by the

cartridge manufacturer should be used. However, if you do not have these screws, proceed as follows:

From the three sets of screws supplied with the B-I-C 980 and 960, select the screws that appear to be the proper length to pass through the *cartridge mounting bracket*. Place one screw through the *bracket*.

To make certain it is not too long, place the bottom of the cartridge as shown in the diagram below and note whether the screw projects below the simulated *shell mounting bracket*. If too long, use the next shorter screw. When the correct length has been selected, use a small screw driver to secure both screws.

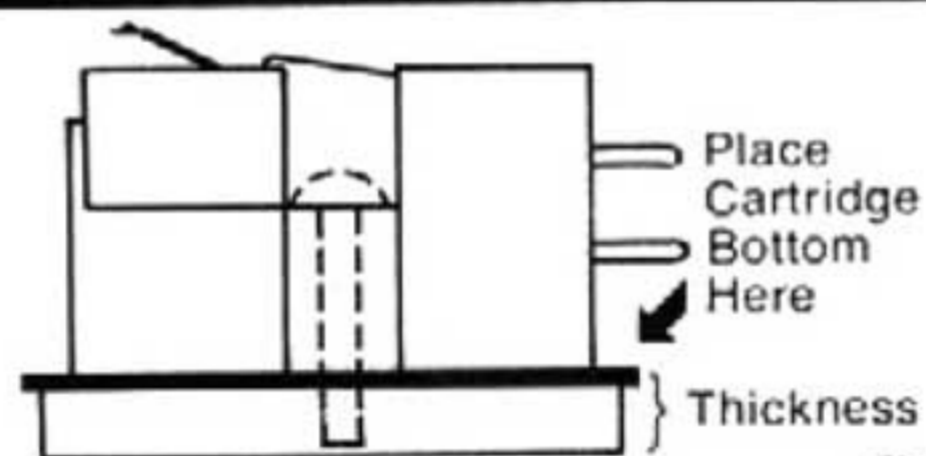

Wiring Cartridge

Grasp each of the push-on connectors with a pair of long nosed pliers, and push on to the appropriate pins at the rear of the cartridge. The chart illustrates the markings at the rear of a typical cartridge. **MAKE CERTAIN** that the cartridge is wired as per the following code.

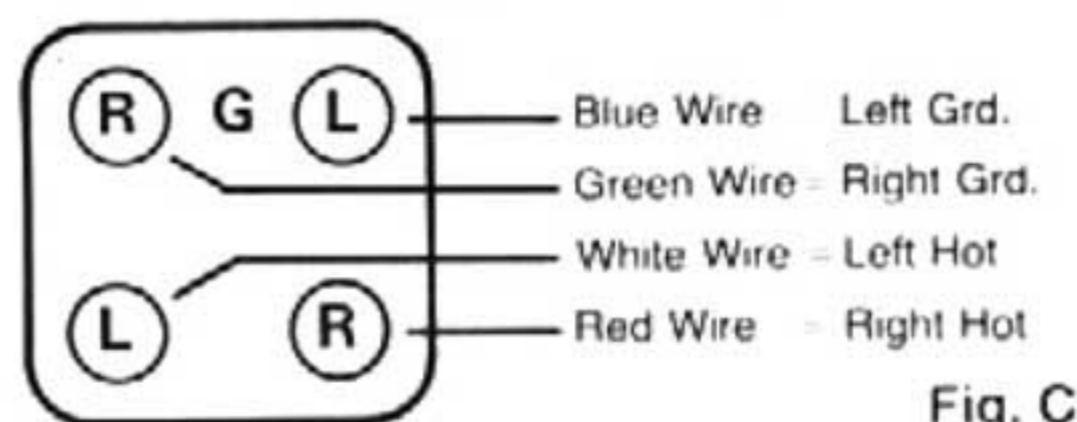

CAUTION—Never solder directly to the cartridge. DAMAGE WILL OCCUR

Cartridge Grounding Strap

All B-I-C 960's and 980's are equipped with a shielded head shell which is grounded. When this system is used with cartridges that have metal bodies and mounting feet, the small metal "grounding" strap on the cartridge must be removed. This will eliminate the formation of ground loops which cause hum. Consult the cartridge manufacturer's instructions regarding removal of the ground strap or contact your dealer.

Stylus Overhang

The position of the stylus relative to the exact center of a record is extremely critical and relates directly to distortion during playback. In the B-I-C 980 and 960, the proper overhang of the stylus is set by means of a separate plastic mounting gauge supplied (Fig. D).

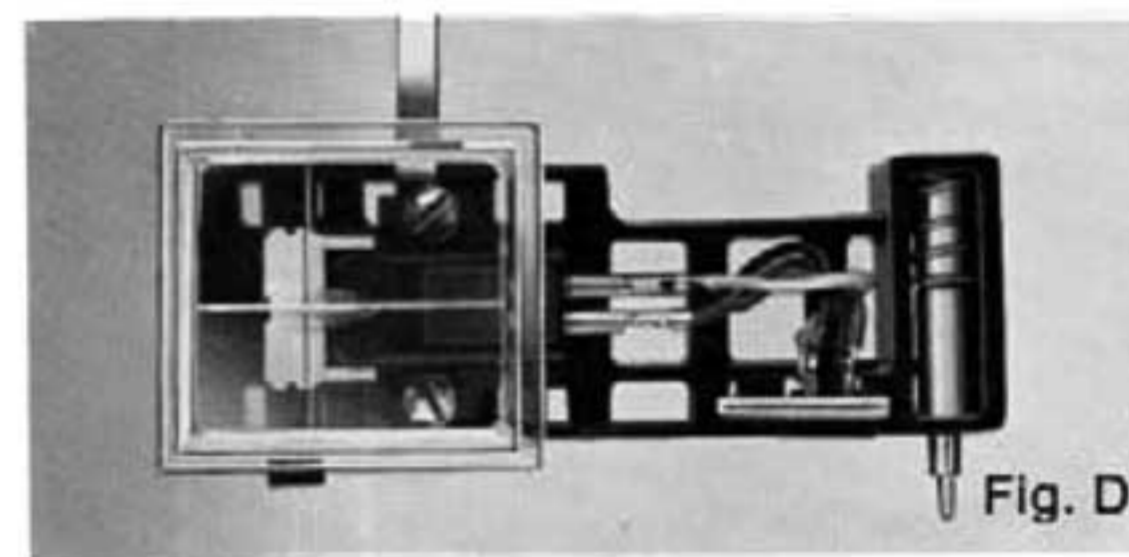

Temporarily remove the stylus guard from your cartridge, if one is supplied. Move the auto/manual selector to the M position. Place the cartridge shell upside down (stylus facing you) on a flat surface, such as the top of a table, or a stack of books with the finger lift overhanging the edge. Place the stylus gauge over the shell firmly pressing it into the corner of the gauge which contains the slot and parallel lines. Determine the position of the stylus in relation to the cross-hairs (Fig. D) of the

gauge. Loosen the cartridge mounting screws and move the cartridge until the stylus tip lies directly under the center of the cross-hairs. Remove the gauge from the shell and re-tighten the mounting screws. Re-check alignment, using the gauge, to make sure the cartridge has not shifted during the tightening process.

Attach Shell to Tonearm

Line up the hole in the rear of the shell with the pivot pin on the tonearm and engage the plug-in socket of the pickup head with the pickup arm (Fig. A, Pg. 6). (The connector in the tonearm is a floating, self-aligning connector.) Press the pickup head into the tonearm. Re-install the head locking nut but do not fully tighten.

Counterweight Installation

The counterweight should be installed on the tonearm in the following manner: Place the counterweight at the end of the tonearm, with the knurl facing the rear, and rotate it in a counter-clockwise direction (Fig. A). The counterweight must be assembled and taken off the tonearm *only by a winding action*—not by directly pushing or pulling. Rotate the platter in a *clockwise* direction approximately 5 turns to make certain that the mechanism is free and the unit is not in cycle. Also, make certain that the cueing lever is in the play

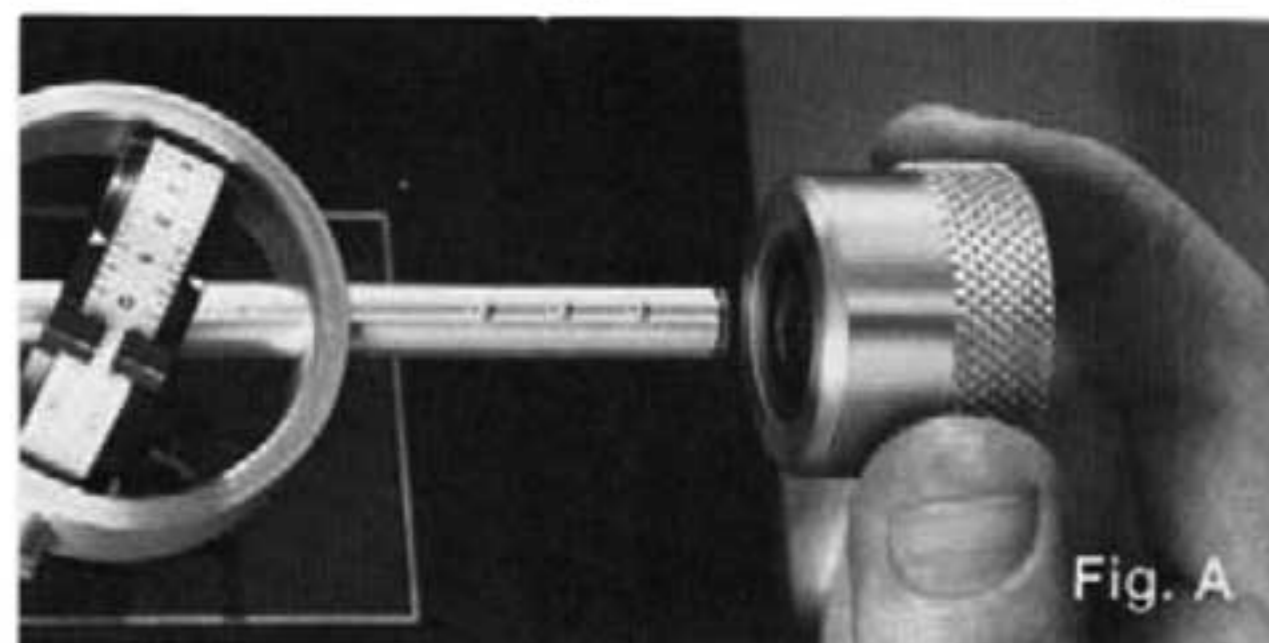

Fig. A

position. With the tonearm released from its locked position and both anti-skate and tracking force levers set to 0 (zero), continue to rotate the counterweight until the tonearm is perfectly balanced, floating parallel to the turntable. When this is accomplished, the tonearm will be at the approximate level of the extension on the tonearm pickup rest.

Selecting Proper Anti-Skate Mode

The physical and geometric relationships of *all* offset tonearms give rise to an inward force during record play which applies lateral forces against the inner groove wall of a record. This force is called "skating" and must be countered by an equal and opposite force if minimum record wear and optimum tracking is to be achieved.

The anti-skating systems on the 980 and 960 are unique in a number of respects. On all automatic turntables,



Fig. B

and even on many manual players, a double scale is employed to permit settings for the differences in the amount of force needed when using an elliptical or conical stylus. Not only is this confusing and difficult to set, but in actual fact, this method involves a compromise since one force is being used to create both compensations. In the Models 980 and 960, the reference point for elliptical and conical styli is preset by a separate function lever (Fig. B).

Shift the conical \circ /elliptical \ominus stylus mode selector to the appropriate posi-

tion—conical or elliptical, depending upon the type of stylus used in your cartridge. For other types of styli, such as Shibata or CD-4 cartridges, consult the cartridge manufacturer's recommendation for anti-skating calibration.

Setting Stylus and Anti-Skate Force

Set both anti-skating and stylus force levers to the number of grams recommended by the manufacturer of your cartridge (Fig. C). Although tracking force and anti-skate settings can be made individually, the controls can also be operated in tandem.

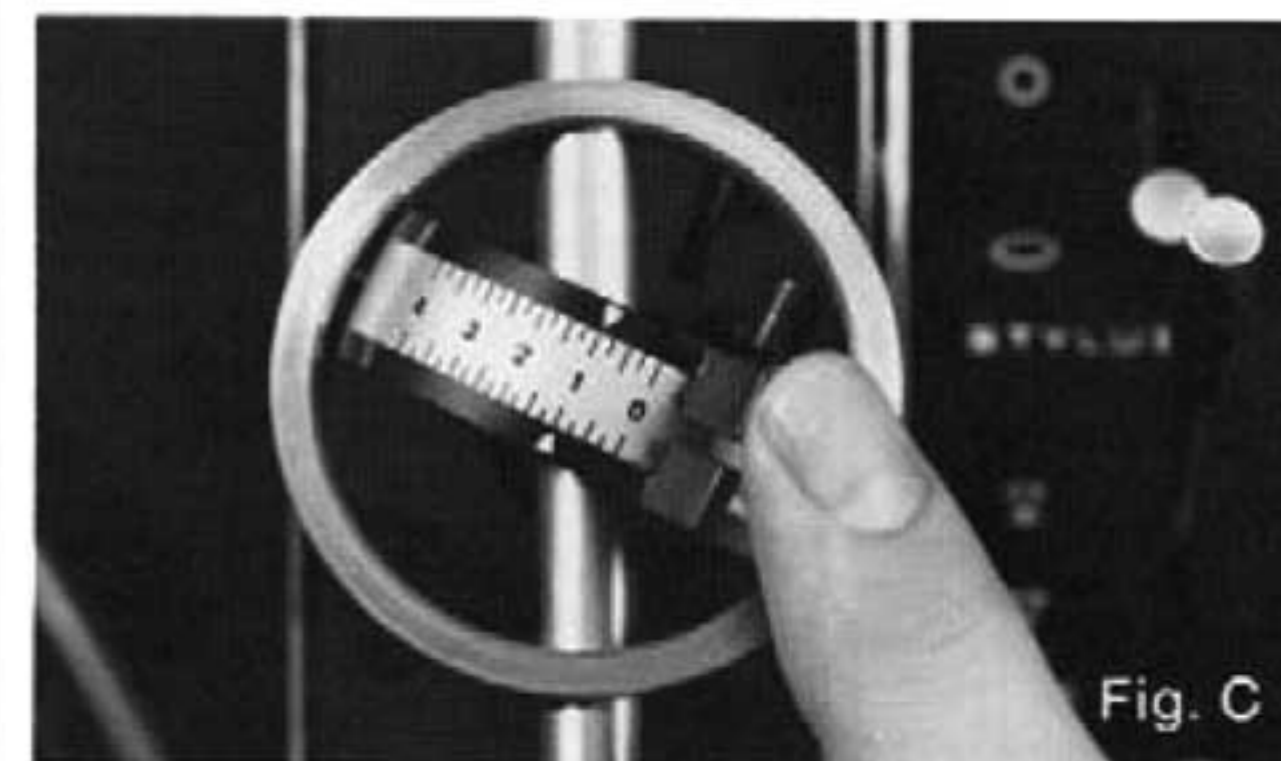

Fig. C

Cartridge Angle Adjustment

Place the setting gauge on the flat (non-ribbed) surface of one of the spokes of the turntable mat (Fig. A, pg. 8). **DO NOT PLACE THE GAUGE ON THE BLACK DISC.**

Set the auto/manual selector at the front of the tonearm shell to the manual (M) position. Gently place the stylus on the gauge supplied and sight the location of the top surface of the pick-up head in relationship to the parallel lines of the setting gauge. Ideally, the top surface of the pick-up head should be parallel with the lines on the gauge. This can be achieved by turning the adjusting screw with a small screwdriver. Make this adjustment with the

tonearm elevated over the gauge to avoid any damage to your stylus (Fig. A). Lower to gauge and re-check. Once the correct position is achieved, fully tighten the pick-up head locking nut.

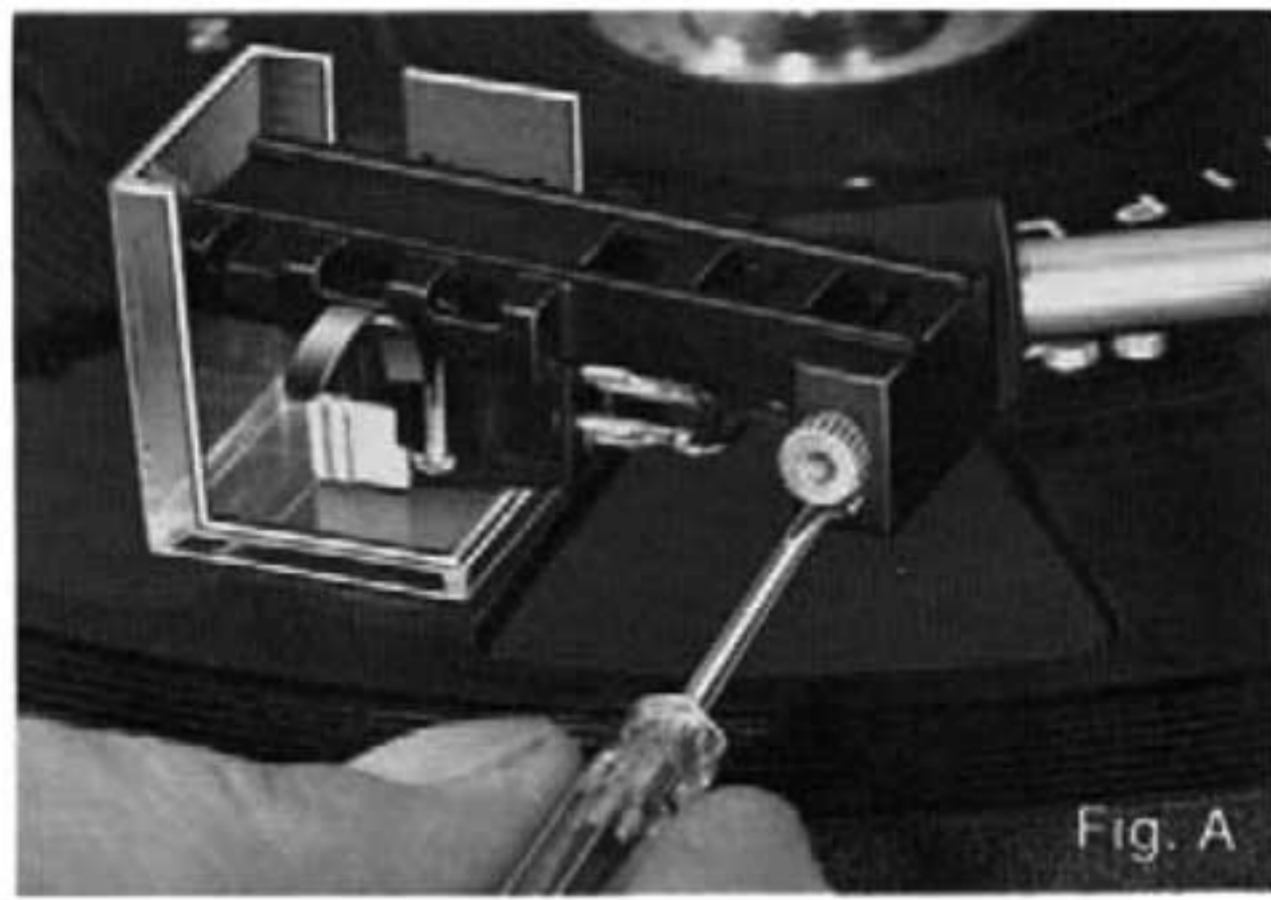

Fig. A

Connecting Your B-I-C Turntable to an Audio Amplifier

Audio Cable

Models 980 and 960 are supplied with a double ended color coded audio cable. This cable was selected to provide minimum capacitive loading effects on high frequency response of your cartridge. This is especially important if your cartridge is capable of playing CD-4 discrete four channel recordings. If longer cables are required, make certain they are of a low capacity type or check with the manufacturer of your



Fig. B

cartridge for his recommendations regarding cable type and length limitations.

Unravel the cable and insert one of the plugs into the phono socket marked "R" on the underside of the unit. Insert the other color plug into the socket marked "L". Make certain the plugs are pressed all the way in (Fig. B).

Feed the cable, line cord and black ground lead through the base as shown on the base instruction sheet.

Note the color of the plug going to "R" on the unit and insert the same color at the other end into the right channel of the amplifier. Follow the same procedure for the left channel.

Amplifier Connections

If you are using a magnetic phono cartridge, insert the phono plugs into the space provided at the rear of the amplifier marked "phono low level" or "phono MAG" (Fig. C).



Fig. C

If you are using a ceramic cartridge, insert the audio cable plugs into the high level input of the amplifier (phono CER).

The ground wire supplied with the turntable should be connected to a suitable "ground" point on the metal chassis of your amplifier. Most am-

plifiers provide a convenient terminal on the rear panel for this purpose. Failure to ground this wire will result in an inordinately high hum level when attempting to play records.

Power Cord Connection

Your Model 980 or 960 Programmed Turntable was designed to operate from a supply voltage of 105 to 130 VAC, 50 (adapter required) or 60 Hz. *Connection of the power cord to a higher source of voltage or to a DC power source will cause immediate damage to the unit and is not covered by the warranty.* If you use this product in areas powered by 220 or 240 volts, consult your dealer for proper instructions regarding adaptation of the unit for such use.

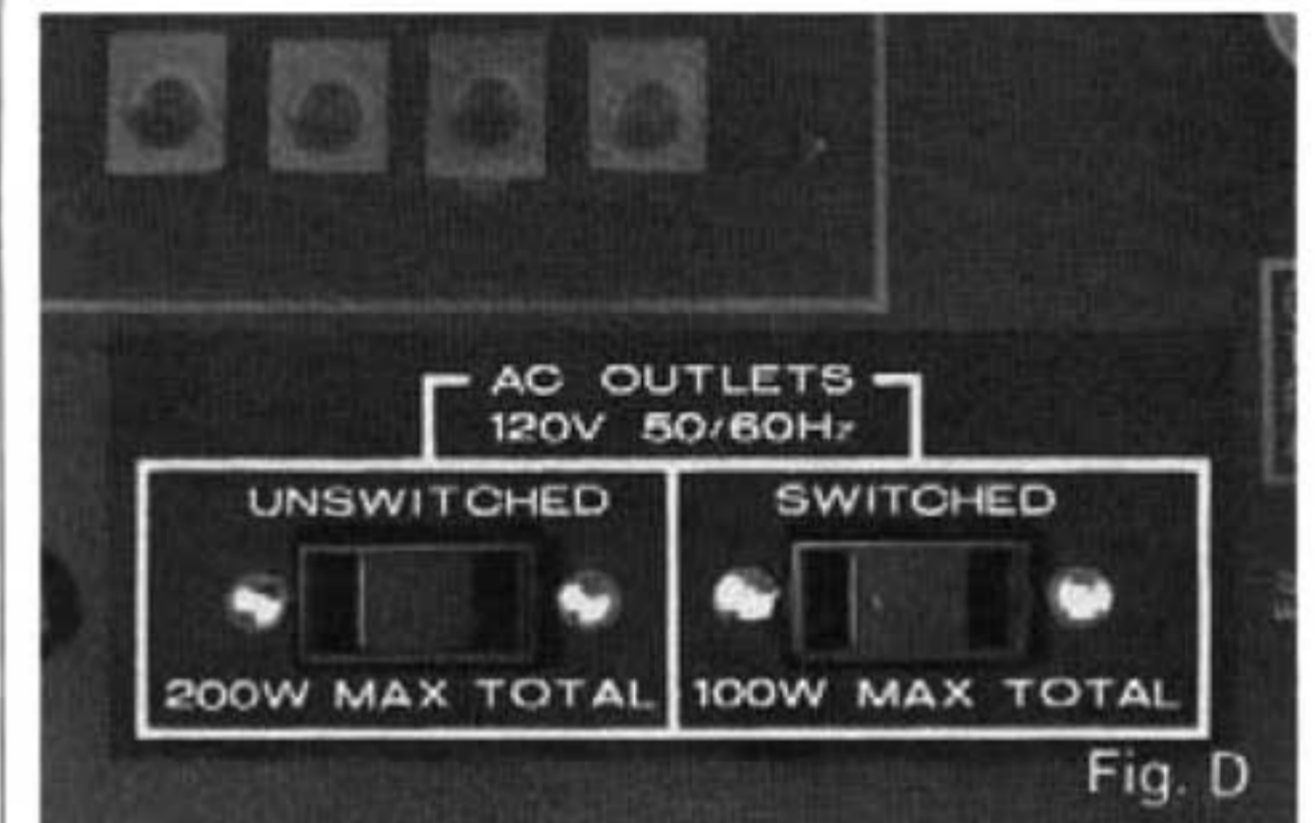

Fig. D

With the programming lever set to the OFF position, plug the power cord into a suitable outlet. Many amplifiers provide convenient receptacles on their rear panels, to which the turntable power cord may be connected, (Fig. D). Often, these receptacles are labelled "SWITCHED" and "UNSWITCHED". Choose an "UNSWITCHED" receptacle for powering the turntable. By so doing, if you shut off the amplifier, the turntable will continue to rotate until its selected programming sequence is completed.

Operating Procedure

Before attempting to play records on your B-I-C Belt Drive Programmed Turntable, make certain that the tonearm retaining lock (Fig. A) on the tonearm rest is loosened by moving it to the right with forefinger. Most cartridges are fitted with a stylus guard or protective cover. Make certain this cover is removed or pivoted so as to expose the stylus tip.



Fig. A

Set the speed selector lever (Fig. B) for the type of record you wish to play. The Models 980 and 960 play 12" 33 rpm records when the speed selector lever is set for 33; 7" 45 rpm records when set to 45. When playing a 45 rpm record, install the manual 45 rpm adaptor over the manual spindle, which should be placed in the center hole of the turntable. Place a record on the turntable and make sure the auto/manual selector located on the front of the cartridge shell is set to the correct position. If playing one record move the auto/manual selector (Fig. A) to reveal the letter "M"; if playing more than one record, move the compensator to reveal the letter "A". An optional multiple play 45 rpm adaptor is available.

Place this adaptor over the automatic spindle to play up to six records. (See page 10.)

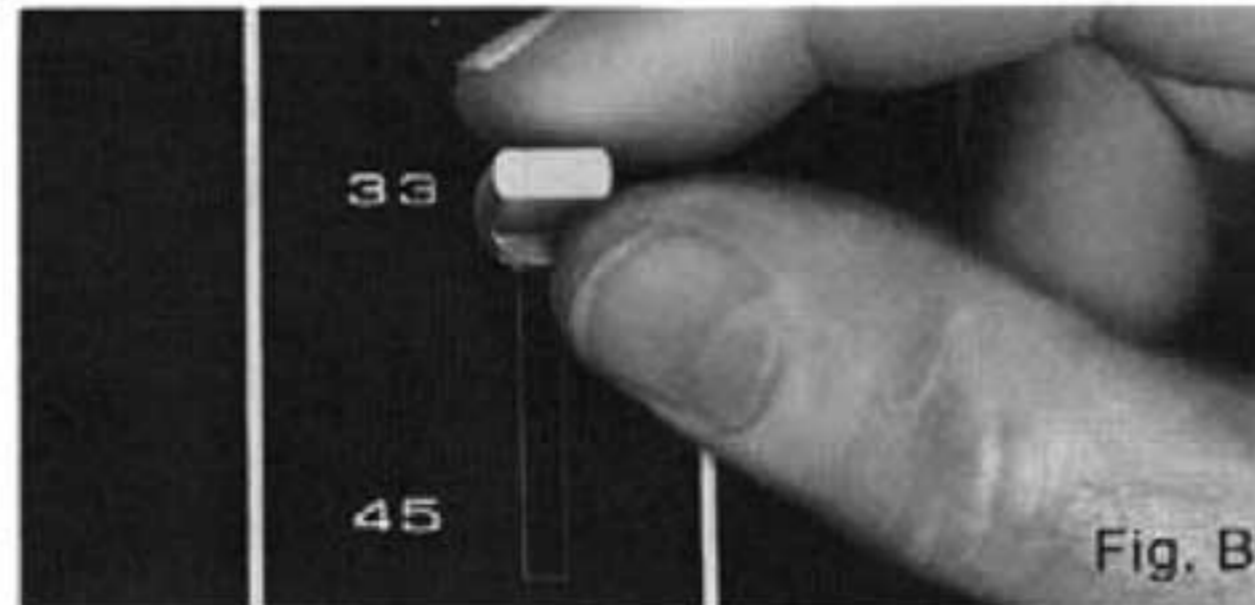

Fig. B

Manual Play of a Single Record

Insert the manual spindle and move the programmer control knob (Fig. C) to the manual position. The turntable should begin to rotate at the selected speed. Carefully lift the tonearm by means of the tonearm finger lift, and place it on the record. After the record has been played, the tonearm will return to the tonearm rest and the unit will shut off. You may also use the cueing lever while playing single records manually. For use of this feature, refer to page 11. If you wish to discontinue playing in the middle of a record, press the cycle button. The tonearm will return to its rest, and the unit will shut off. Alternatively, you may lift the tonearm from the record and manually return it to the rest. The turntable should then be turned off by moving the programming lever to the OFF position.

DO NOT MOVE THE PROGRAMMER WITH THE TONEARM ON A RECORD.

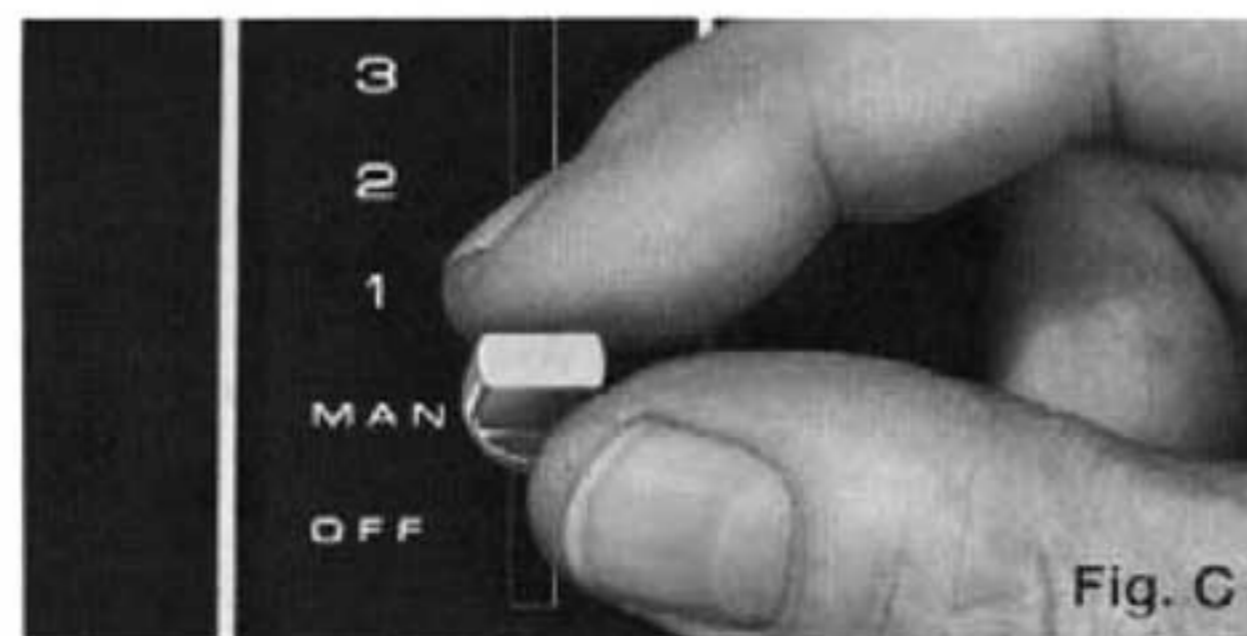

Fig. C

Electronic Speed Control (Model 980 Only)

The Model 980 is equipped with an electronic pitch control (Fig. D) which permits speed adjustment over a range of $\pm 3\%$. Many automatic and manual turntables having variable speed adjustment do not permit the viewing of a stroboscope while the unit is playing. They employ printed strobes on the turntable or require the use of a separate strobe card. The Model 980 has a brightly illuminated mirrored window, just behind the variable pitch speed control, to monitor turntable speed at any time.

While a record is playing, observe the lines inscribed in the illuminated stroboscope window. Rotate the pitch control until the lines appear to be stationary. When the lines stand still, correct, accurate speed of rotation is indicated. Rotate the pitch control clockwise for increased speed, counter-clockwise to reduce speed.



Fig. D

Model 960

The Model 960 contains a synchronous 24-pole 300 rpm motor which is locked into the power line frequency, and the turntable will therefore rotate at precisely $33\frac{1}{3}$ rpm or 45 rpm.

Repeat Play of a Single Record

Here is another B-I-C feature: If you would like to hear one twelve-inch record played three times, simply advance the programmer to the number 3. With the tonearm on the pickup rest, depress the cycle button and the unit will play the record three times and shut off.

Automatic Play of a Single Record

To play a single record automatically, advance the programmer to the number 1 setting and depress the cycle button. This cycle button initiates totally automatic operation. The arm rises, comes to the edge of the record, and is gently lowered.

At the end of record play, the tonearm returns to the rest and the machine automatically shuts off. If you move the programmer to the number 1 setting and place the tonearm on the record, the unit will not shut off at the end of the record, but will continue to play the record one more time.

Turning Off the Unit

The unit can be turned off at any time in one of two ways:

The cycle button can be depressed to advance the programming cycle to the next lower program number until the "MAN" position is reached. Depressing the cycle button once again will cause the tonearm to return to the tonearm rest and complete shut off of the turntable.



Alternatively, the tonearm can be lifted manually by means of the tonearm finger lift and returned to the tonearm rest. The programming lever should then be moved to the OFF position to turn off the unit (Fig. A).

Automatic Multiple Record Play

Your Model 980 or 960 can be used to play multiple records automatically, but with important differences when compared with units which are commonly categorized as "automatic turntables".

The B-I-C mechanism is exceptionally simple, with a minimum number of moving parts.

Records are handled with two-point support, as opposed to the umbrella-type single-support system commonly used. The B-I-C system stabilizes the records and insures reliable dropping. There are other automatic turntables that use a two-point record support system, but the 980 and 960 differ in that automatic shut-off is completely independent of the center automatic spindle. This eliminates the critical sensing nature of the spindle and is one of the reasons for the reliable changing capabilities of the B-I-C unit.

This design also makes it much simpler to accommodate records with variations in the center hole diameter or thickness.

Installing Plug-In Record Platform

Each B-I-C 960 and 980 contains a plug-in record platform supplied in the styrofoam filler. The record platform contains a pin which mates with a keyway in the record platform socket located in the left-hand, rear portion of the unit. Locate the pin in the keyway and press the record platform



firmly down until it locates in a positive manner. When playing records manually, the record platform can be removed or left in place. (Fig. B)

Installing Multiple Play Spindle

To play up to six records in sequence, remove the short manual spindle from the turntable.

Place the multiple play spindle in the center of the turntable. Rotate it until it lines itself up with the keyway in the center of the turntable. Press the spindle firmly down until a distinct "click" is heard.

Count the number of records you are putting on the multiple play spindle and place the record hold-down clip (Fig. C) on the platform in the up position prior to installing records. When the records are sitting on the shelf of the spindle and the edge of the record platform, lower the hold-down clip to stabilize the records.

Move the program selector control knob to the number corresponding to the records you have placed on the spindle. Press the cycle button and the tonearm will play all of the records automatically. When the last record has played, the unit will shut off. For example, to play four records, the four records are placed on the automatic

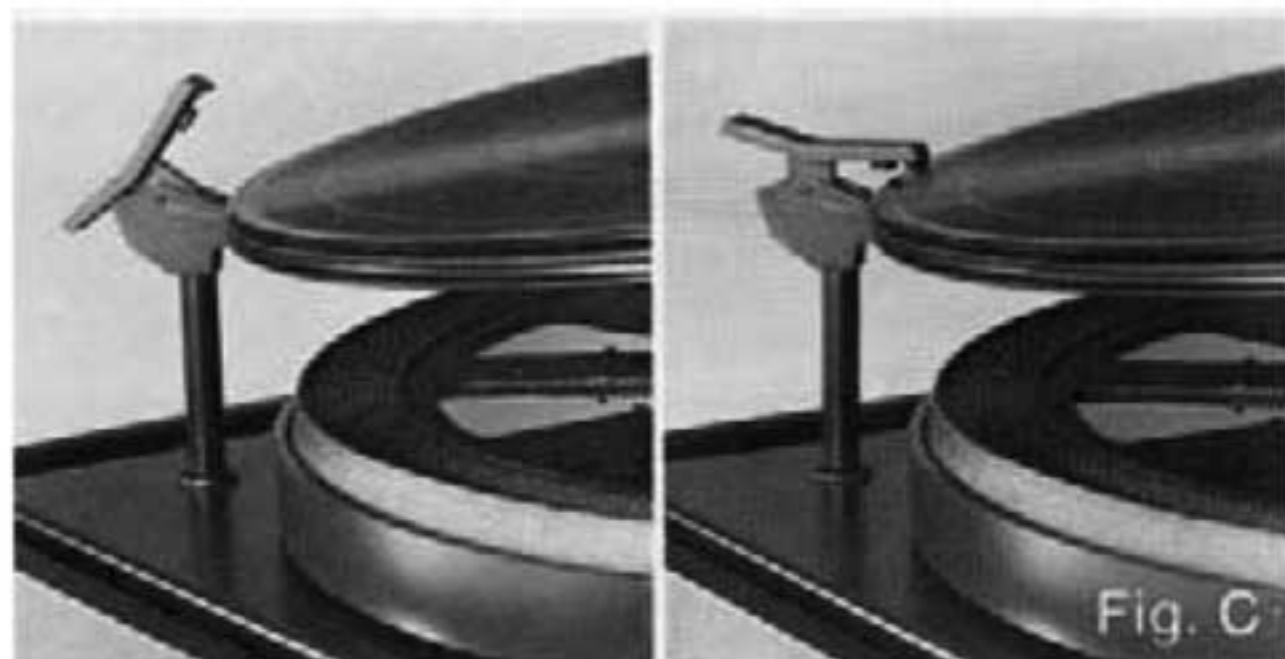

spindle and the programmer is advanced to 4. The cycle button is depressed, the four records play and the programmer determines when it is to shut off.

Multiple Play Plus Repeat of the Last Record

If you wish to play less than six records and would like the last record to be repeated one or more times, simply move the program selector knob to the number of records plus the number of additional plays desired. For example, if three records are on the spindle and you wish the last record to play once and repeat three times, simply set the program control to the number 6. (Fig. A).

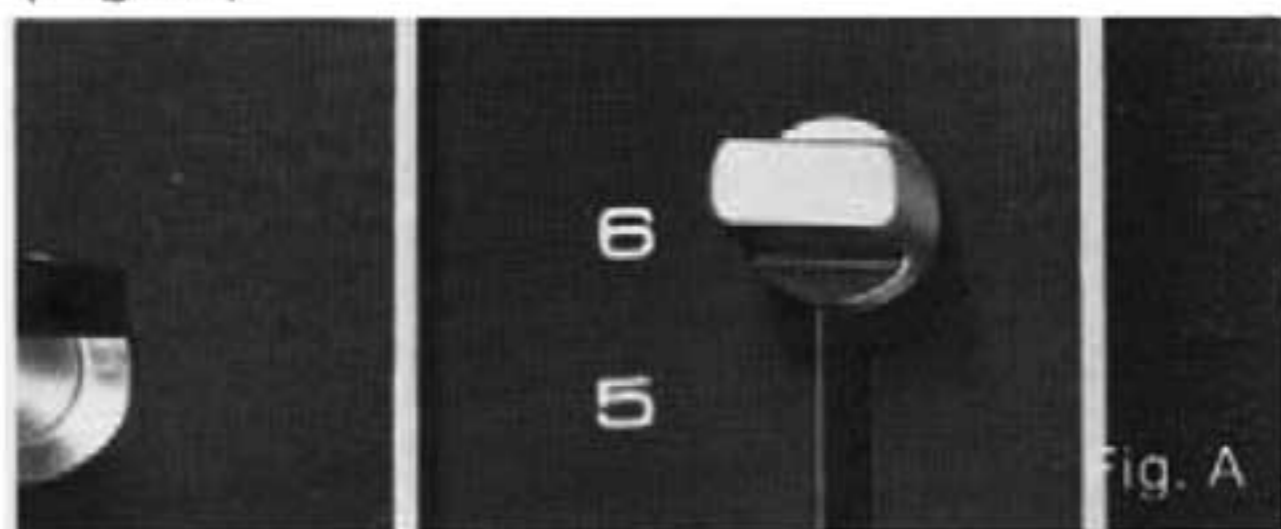

Removing Multiple Play Spindle

All records must first be removed. To remove the records, tilt the stack down and away from the record platform and lift up. The automatic spindle can then be removed by grasping and lifting straight up.

Cueing and Pause Control

The cueing lever (Fig. B) is used to raise or lower the tonearm during automatic or manual play. Moving the control forward raises the tonearm, pushing it back lowers the tonearm.

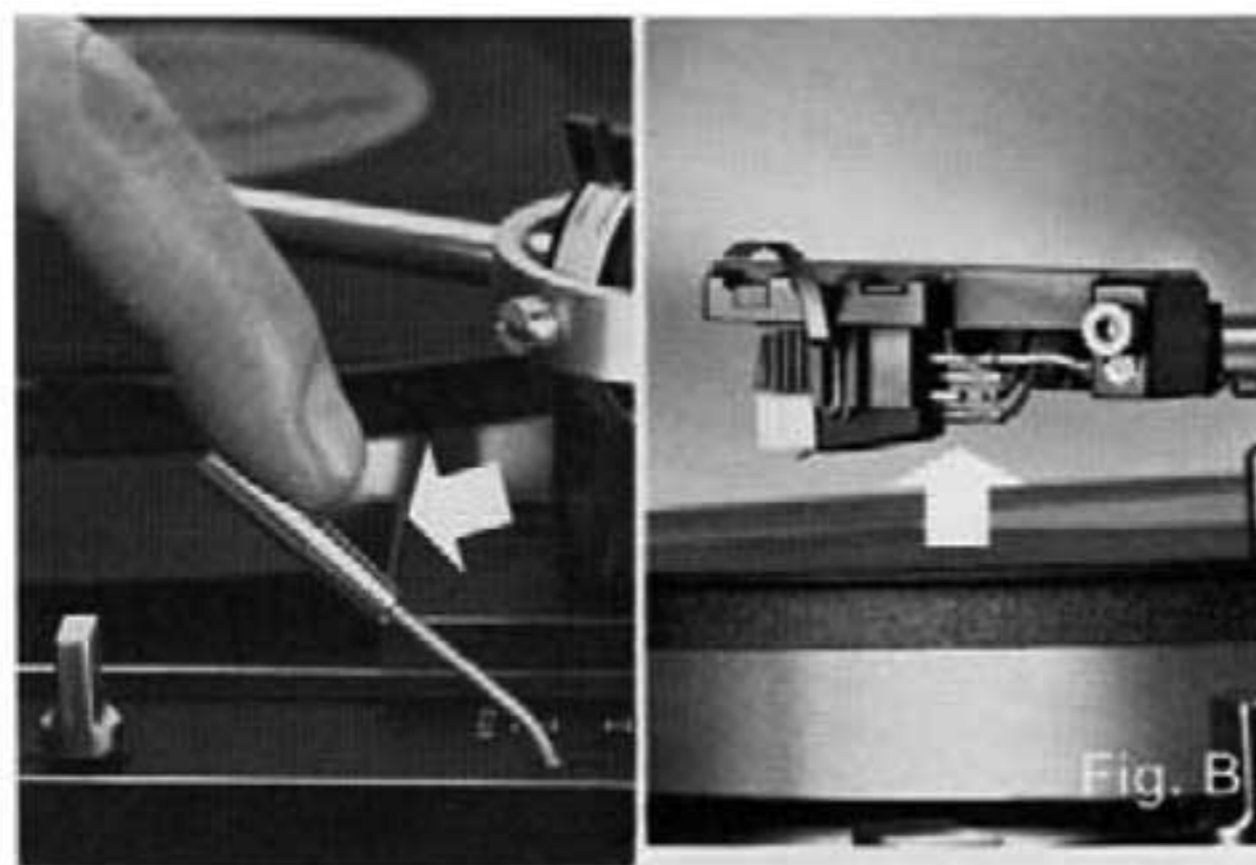

Cueing Rate Adjustment

Today, most manual and automatic turntables have a cueing device, and many are damped in both upward and downward motions. However, whether damping is accomplished by dashpots, springs, or other devices, they are all pre-set at the factory. This poses two problems:

First, temperature can affect the rate of cueing so that in hot climates the rate of drop is fast (frequently too fast) and in cold weather, may be too slow.

Second, the user normally has his own preferences as to the speed at which he wants the cueing to operate, and has been powerless to control it.

The Models 980 and 960 incorporate, for the first time in any tonearm, a variable control with which the owner can set the rate of cueing to his preference or compensate for temperature variations. The cueing rate can be increased or decreased by a knurled control knob, easily accessible from the top surface of the unit. (Fig. C).

Turning the knob in a clockwise direction will decrease the rate of cueing; counter-clockwise rotation will increase the cueing rate. When turning the knob to its maximum up or down position, do not force it beyond the stop point.

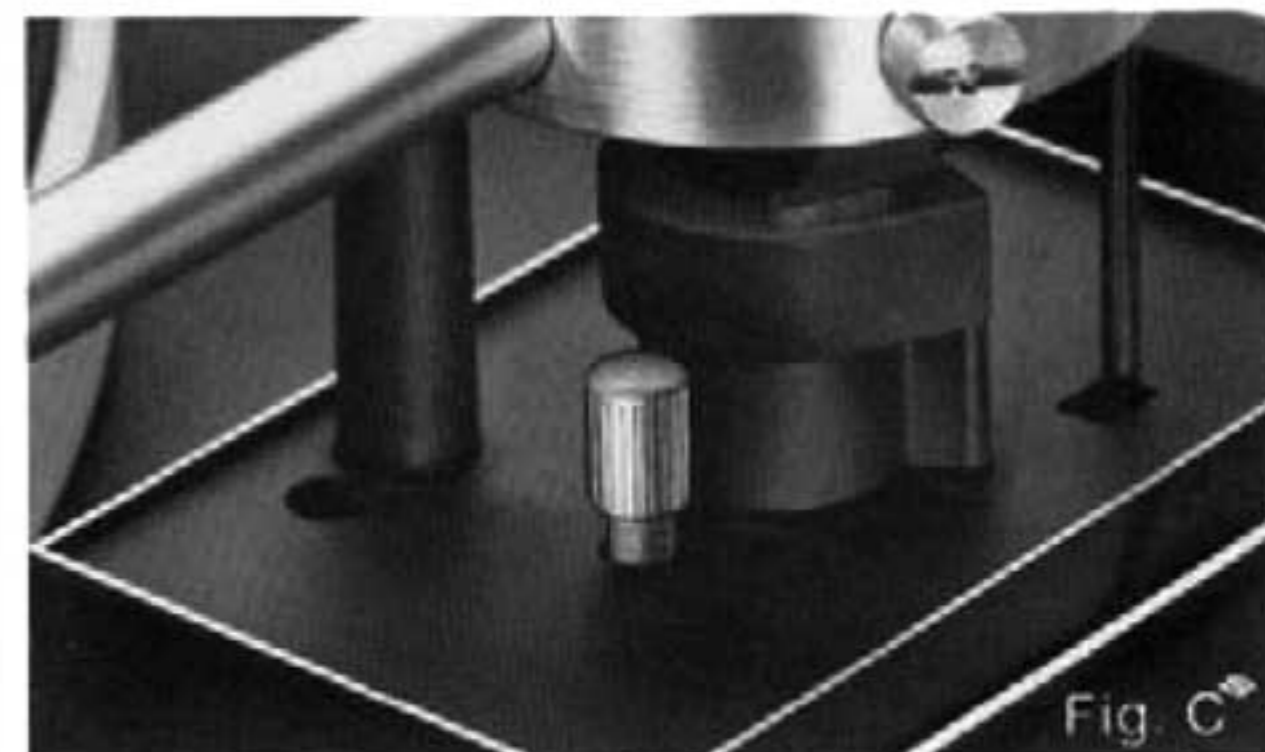

Stylus Set-Down Adjustment and Tonearm Height

Your Model 980 or 960 was carefully assembled and all necessary adjustments were performed at the factory. There are, however, two minor adjustments that may have to be made to suit your particular cartridge. One adjustment controls the point at which the stylus lands upon the record's surface. All records contain a groove guard (Fig. D) Ideally, the stylus should land inside the groove guard just before the recorded portion of the record (Fig. D). The tonearm set-down adjusting screw controls the exact point of set-down. To reposition the tonearm to land inside the groove guard, turn the adjusting

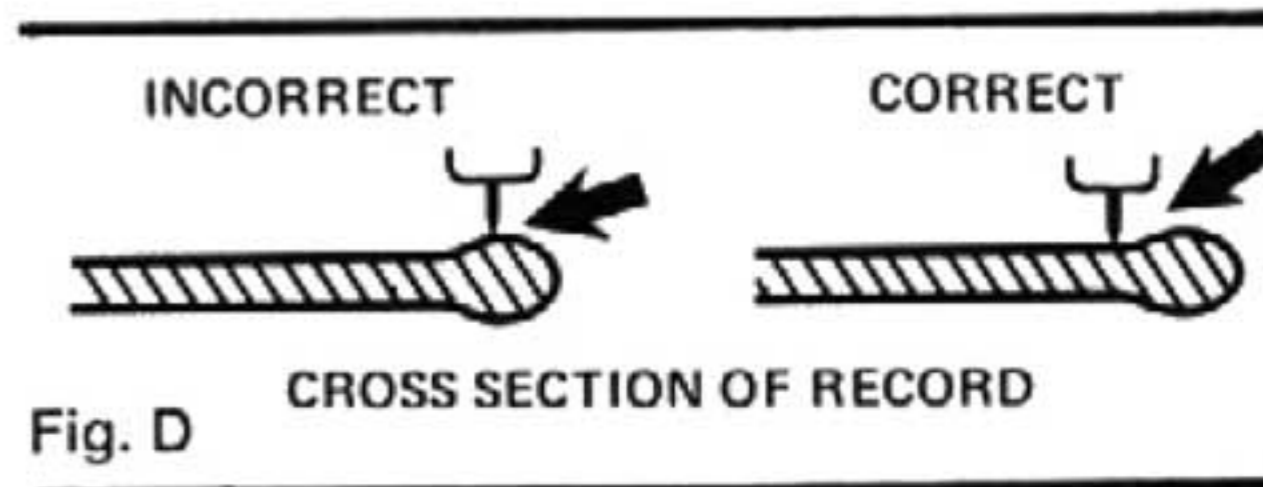

Maintenance and Record Care

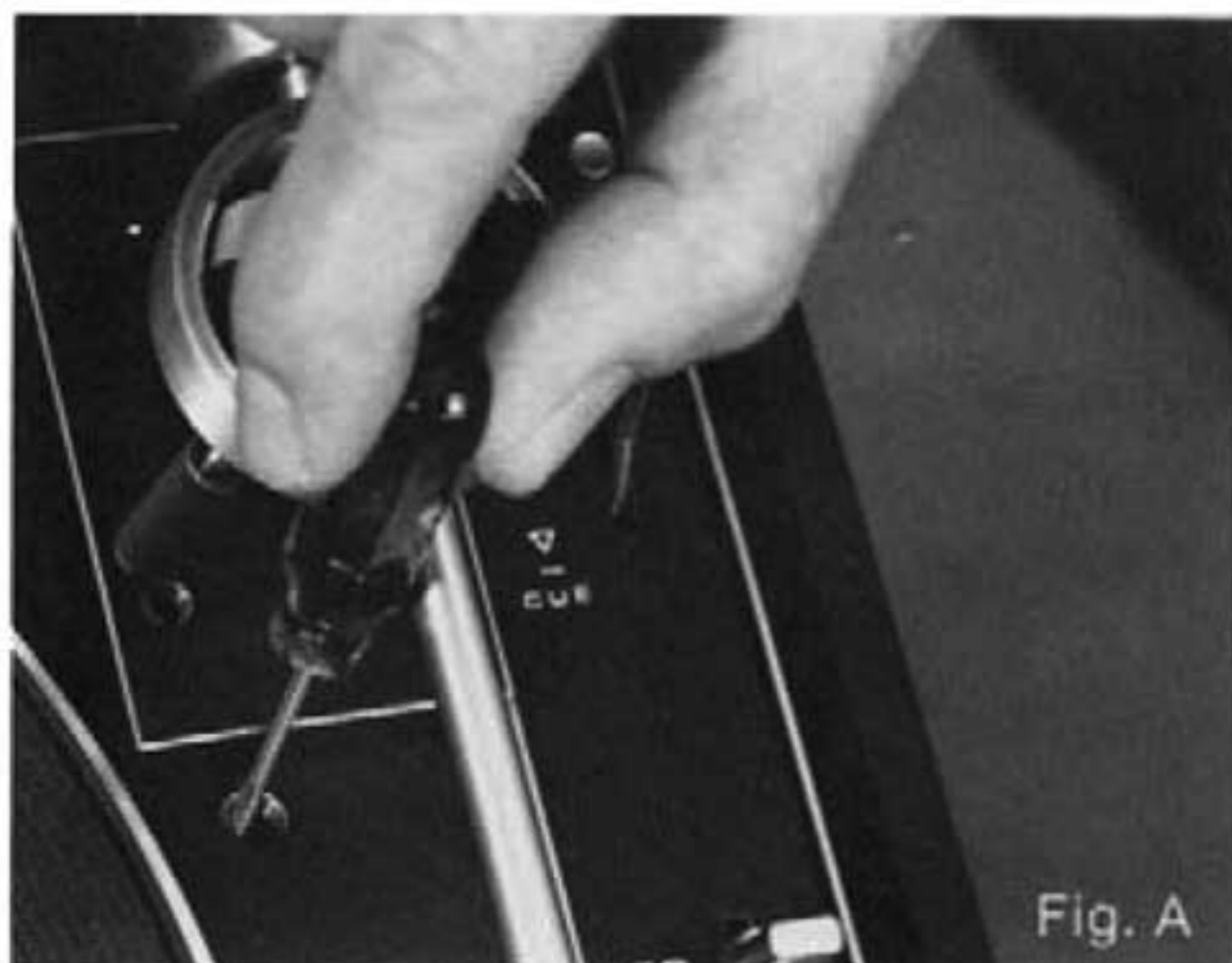

screw (Fig. A) until tonearm is at the correct position.

In rare instances, when very deep or very shallow cartridges are used, adjustment may have to be performed to the pickup height. This adjustment controls the amount of lift to the tonearm in both automatic play and manual cueing. The stylus should lift high enough to clear six records and the tonearm extension. If adjusted too high, the top of the shell will touch the bottom record on the stack. Turning the adjusting screw (Fig. B) counter-clockwise will raise the tonearm; clockwise rotation will lower the tonearm.



Turntable Removal

It is not necessary to remove the turntable mat in order to remove the turntable. The turntable assembly is held in place by a nylon retaining clip located in the center. Remove the spindle and lift one edge of the retaining clip with a screwdriver until the edge of the clip is lifted free (Fig. C). Once this has been done proceed in



the same manner with the other edge of the clip, remove, and lift off the turntable (Fig. D).

A rubber "O" ring and washer may come off with the turntable. Re-insert the

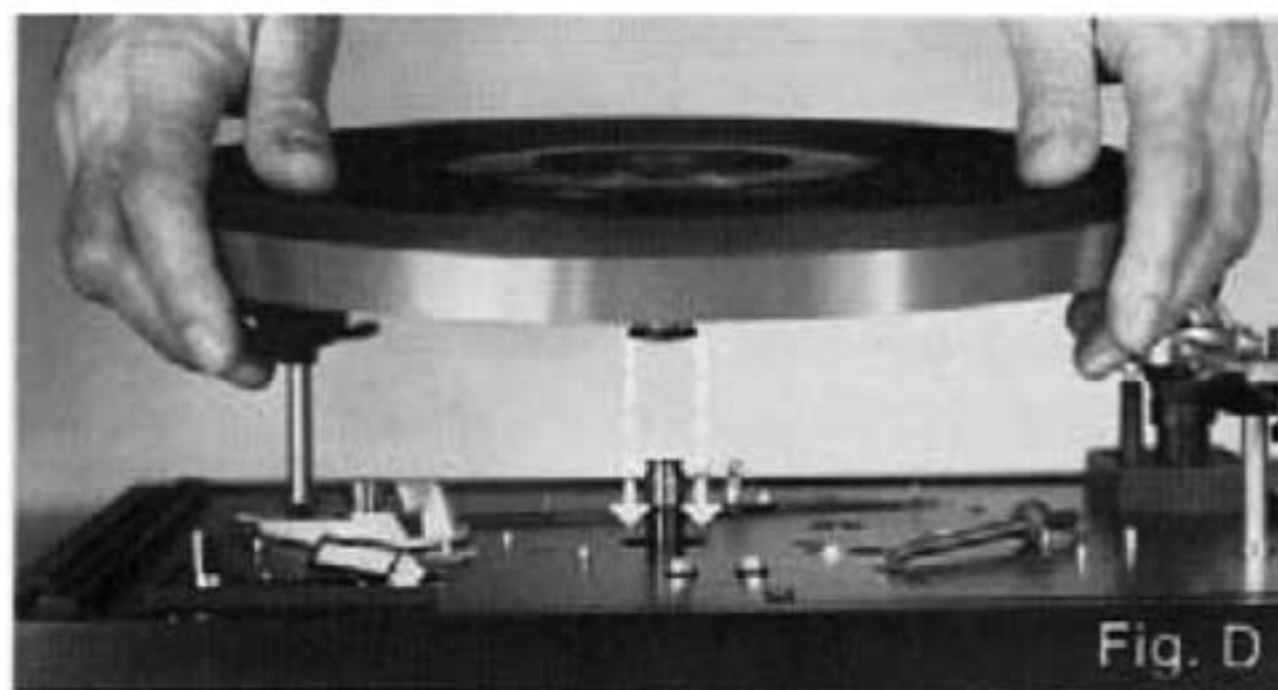

"O" ring and washer onto the turntable spindle. Be sure the "O" ring is atop the washer. Do not lose these parts! When the turntable is re-installed, the rubber "O" ring and washer (already on the spindle) will automatically align with the bottom of the turntable hub (Fig. D).

Belt Installation

When the turntable is removed, the drive belt will come off the rim of the turntable. To re-install the belt onto the platter, place the belt on the drive rim of the turntable (Fig. E). Grasp the belt and engage either one of the two belt retaining studs projecting from the turntable. Do not twist belt. On the top surface of the platter there are two indicators (Fig. F). These indicators line up with the two studs. When re-installing the platter, locate the turntable so that the indicator for the stud retaining the belt is facing your left (parallel to front of machine—Fig. F). Make certain the speed control is set at the 33 position. Place the turntable on the spindle and rotate the turntable clockwise one full turn. The belt will automatically engage the motor pulley.

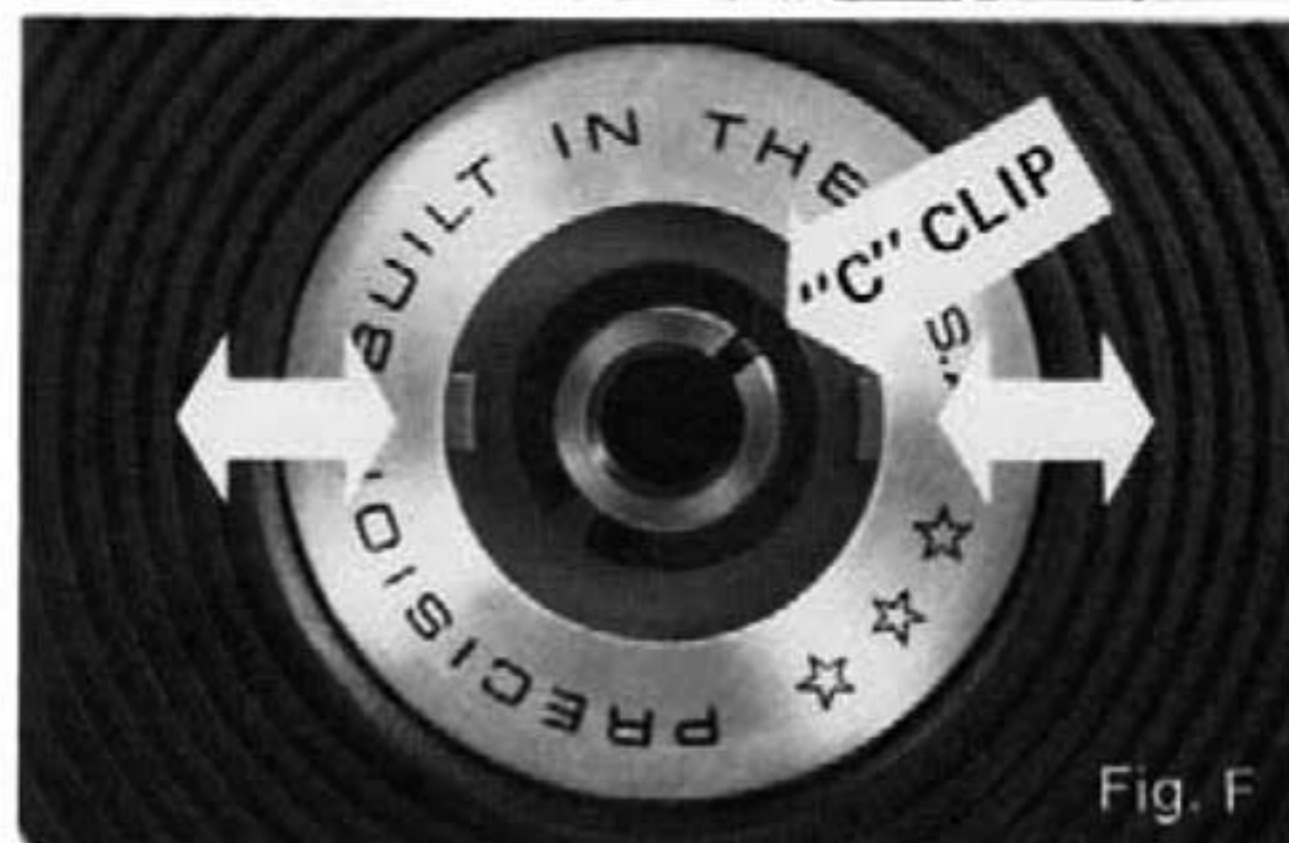
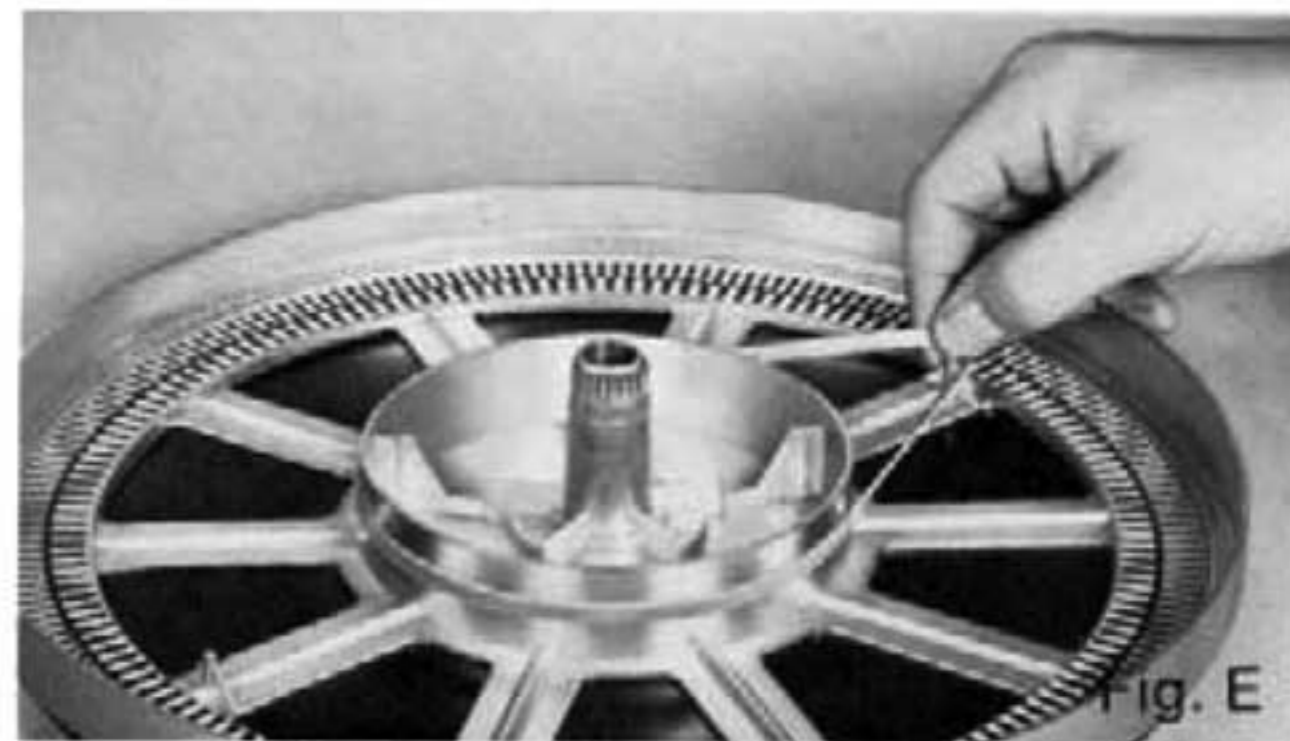

Spare Parts

Re-install the Turntable Retaining "C" Clip

The turntable "C" clip has a projection on both the top and bottom. THIS PROJECTION MUST FIT FULLY INTO THE SLOT OF THE TURNTABLE SPINDLE (Fig. F, page 12).

Lubrication

All pivot points and bearing surfaces have been lubricated at the factory and will seldom, if ever, require further attention. Should lubrication be required, we recommend this be performed by B·I·C or one of its authorized service stations. If you prefer doing this yourself, we recommend you purchase a Technical Service Manual which provides full details and explicit instructions on this entire subject.

Record Care

Keep the cartridge and stylus clean and replace if worn. Periodically have the stylus inspected by your dealer.

Return all records to their protective sleeves and jackets. Do not leave records on the turntable for long periods, if not in use.

Store vertically rather than horizontally or flat. If possible, store records at average room temperatures. Do not permit them near or in contact with heat producing devices, such as radiators, electronic equipment, amplifiers, etc. Excessive temperatures tend to cause warpage of records. Avoid handling the groove surfaces as this will deposit a film of oil on the grooves. Hold records by their outer edges when mounting or removing from turntable to keep records clean.

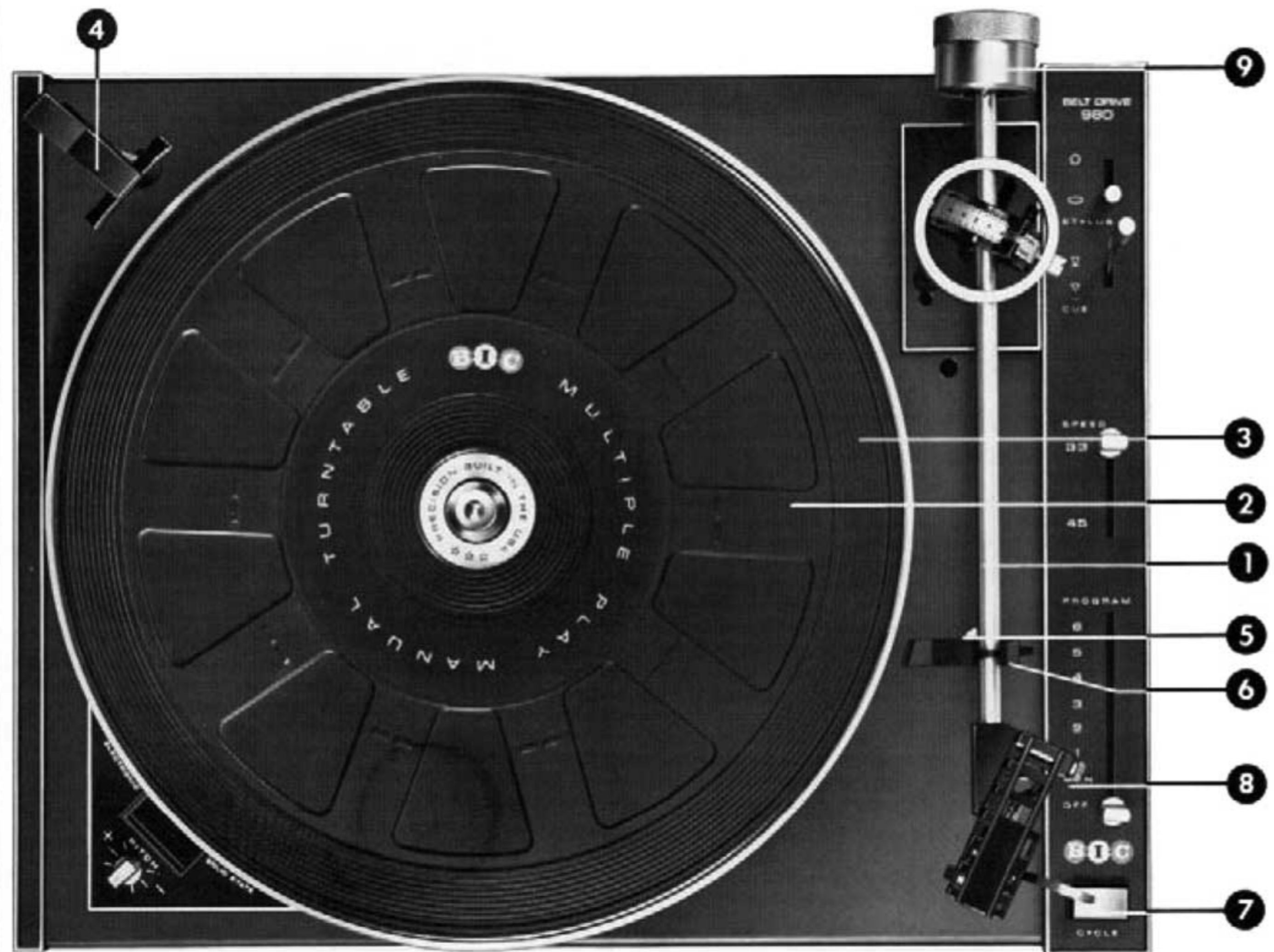

Accessories

- A-2 45 rpm Automatic adaptor (optional)
- A-3 Automatic spindle
- A-4 Manual spindle
- A-5 50 cycle pulley for 960
- A-6 50/60 cycle strobe for 980
- A-7 Elastomer drive belt
- A-8 Stylus setting gauge
- A-9 Shell lock nut/"C" clip/"O" ring
- A-11 Plug-in Head

Part Number and Description

- 1. 10-028-01 Tonearm assembly
- 2. 10-043-08 Turntable & mat assembly with insert (960)
- 3. 10-043-09 Turntable & mat assembly with insert (980)

- 4. 10-223-01 Plug in record platform
- 5. 10-152-01 P/U rest post
- 6. 37-355-01 P/U rest lock
- 7. 38-386-01 Finger lift
- 8. 39-381-02 P/U head locking nut
- 9. 10-026-01 Counterbalance weight

Items Not Shown

- 37-344-01 Cartridge setting gauge
- 37-143-01 T/T retaining clip
- 37-175-01 "O" ring
- 37-539-01 45 rpm manual adaptor
- 17-113-03 Stereo Audio Cable(s)
- 37-540-01 Isolation mount
- 39-602-01 60 cycle pulley

Spare Parts

To insure positive identification of your unit when ordering spare parts, please quote all the information printed on the foil label underneath the unit plate or on the outside of the packing carton. Also quote the part number if listed, the color, the voltage and the power supply frequency.

Please address inquiries for spares and service to your dealer.

In case of difficulty, send your inquiry to:

B-I-C Turntables

Westbury, New York, 11590

(Do not, however, ship a unit to this address)

MINIMUM CABINET DIMENSIONS

UNIT OFF BASE

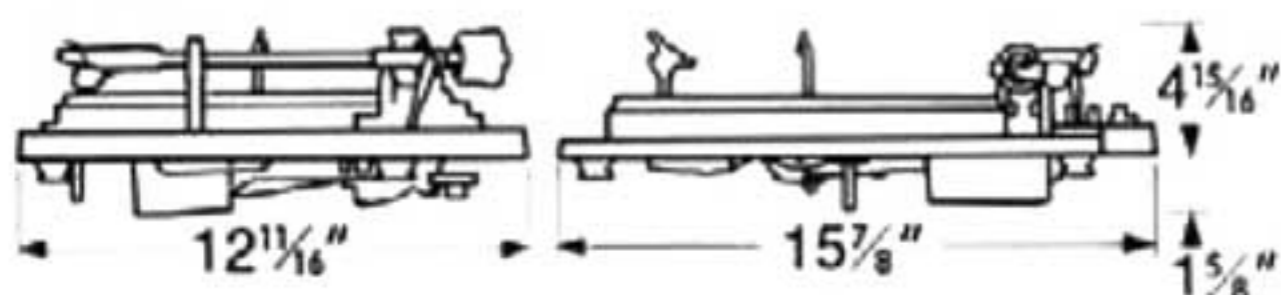

1" additional is required above the unit, for removal of automatic spindle, when placed in a confined space.

UNIT ON BASE WITHOUT DUST COVER

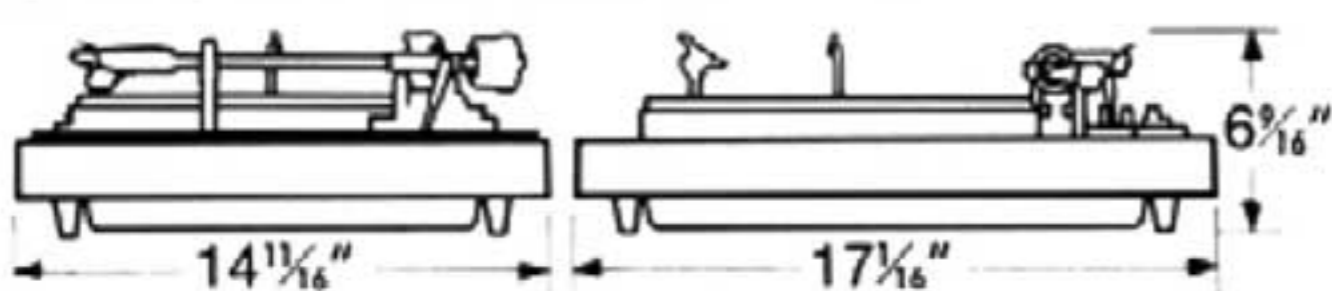

UNIT ON BASE WITH DUST COVER

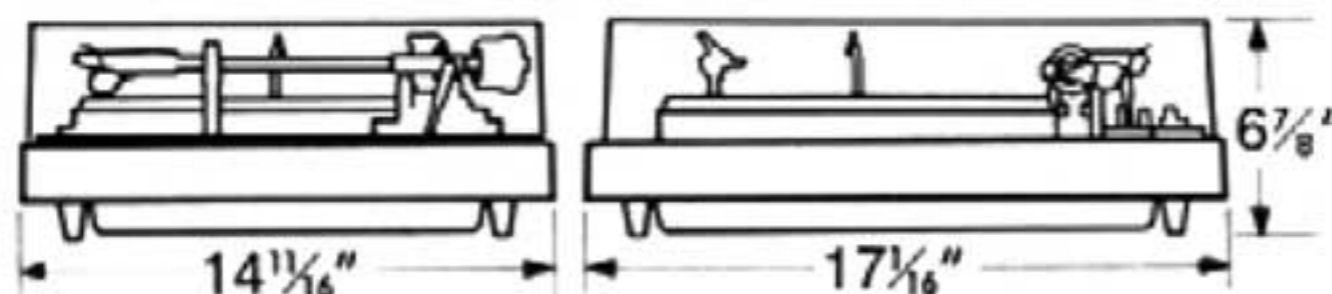

UNIT ON BASE WITH DUST COVER RAISED

Left to right	17 1/16"
Front to rear	20"
Total height	16"
Dust Cover height.....	4 1/4"

Dimensions are with an automatic spindle.

Official Bases

The two bases available for the B-I-C Turntables are as unique in design as the machines themselves. Their low-profile disguises the sturdiness of construction throughout. Both bases include the exclusive "see-through" bottom safety cover which provides maximum protection from mechanical and electrical hazards.

WB20 Wood Base Solid oiled walnut furniture finish. Unitized construction.

B20 Molded Base Molded base with black matte finish for easy care and cleaning. Unitized construction.

Official Dust Cover

D20 The B-I-C Dust Cover fits the B-20 and WB-20 Bases in the 900 series. Its unique construction and design eliminates hinges and other unsightly supports.

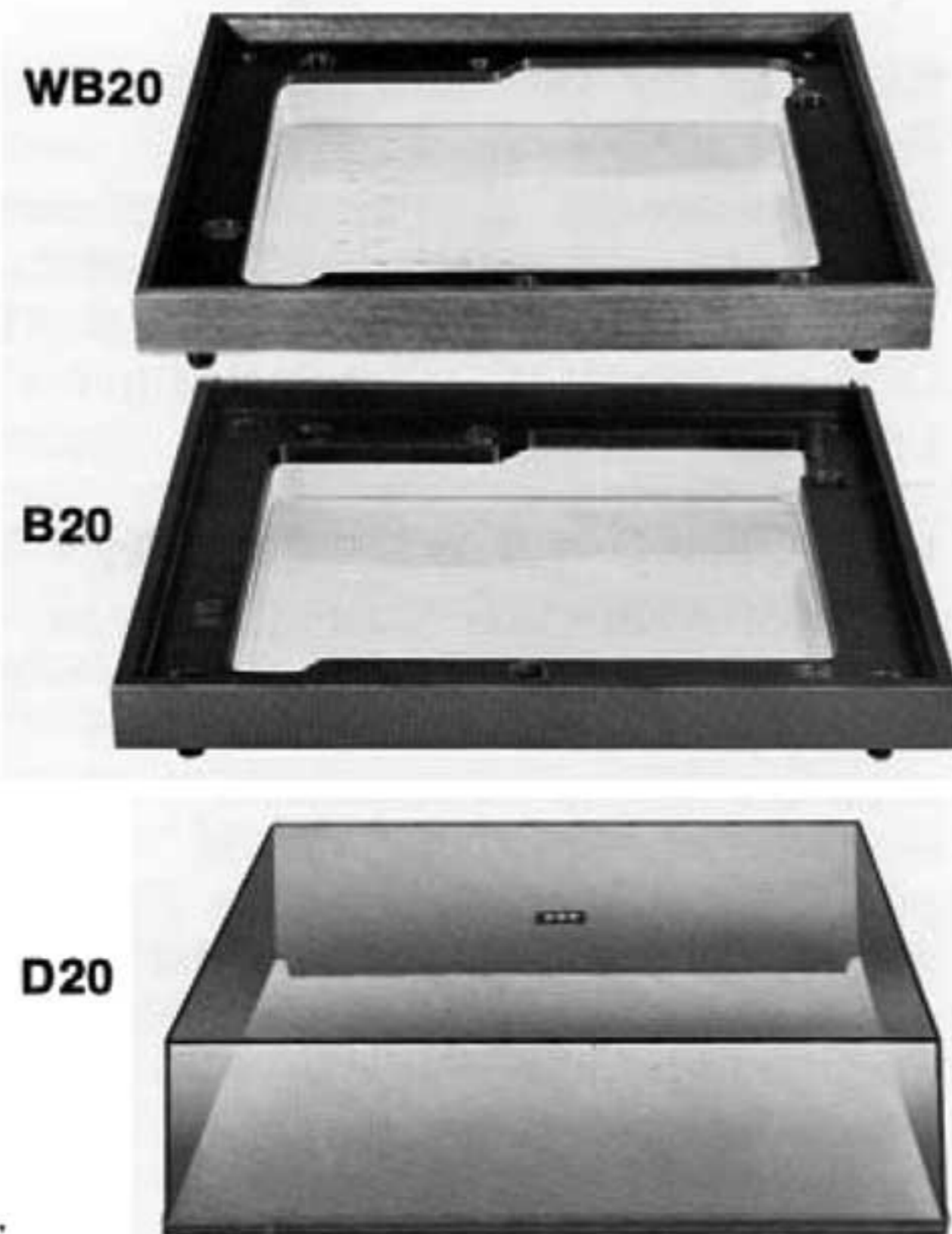

General Specifications

The Models 960 and 980 are wired for 117 volts, 60 cycle operation in the United States. Both units are compatible with 50 cycle operation and can be easily converted. On the underside of all units is a code tag which lists electrical specifications.

The Model 960 requires a 50 cycle pulley while the Model 980 requires a 50 cycle strobe disc. These items available through your dealer or from B-I-C. Detailed information is supplied with each 50 cycle kit. For operation on 220 volts, contact your local dealer or service center for a suitable step-down transformer and conversion.

Cartridge Mounting Screws The Model 980 & 960 are supplied with three pairs of machine screws. Their lengths are 3/16", 1/2" and 5/8" type No. 3-48 American standard machine screws.

Belt The drive belt used is made to exact specifications for maximum performance. If ever a new belt is required, we highly recommend that you purchase the genuine, exact factory replacement as inferior replacement belts will seriously downgrade the performance of your unit. This is also available through your local dealer or B-I-C.

Motor B-I-C Turntables incorporate a 24-pole, 300 rpm motor of outstanding characteristics. The design nature of this motor insures many trouble-free hours of listening pleasure and very seldom, if ever, requires maintenance or lubrication.

Speed The Model 980 & 960 will play records recorded at 33 1/3 and 45 rpm.

Record Size Twelve inch 33 1/3 rpm records may be stacked and played automatically on the automatic spindle supplied with the unit. Seven inch 45 rpm records may be stacked and played automatically on the optional automatic 45 rpm adaptor, Stock No. A-2. All other size 33 1/3 and 45 rpm records can, of course, be played manually.

Maximum Number of Records B-I-C Turntables accept and play up to six records automatically.

Cartridge B-I-C Turntables will accept any cartridge manufactured at the time of this writing, and will track at the lightest force recommended by cartridge manufacturer.

Cable Capacitance The total cable capacitance (all wiring) of the Model 980 & 960 is less than 125 pf and, therefore, is perfectly compatible with Discrete Four Channel records (CD-4).

Trouble Shooting Hints

Disconnect the power cord and protect the stylus before making investigations

SYMPTOM	CAUSE	REMEDY
Unit fails to start or does not turn.	Packing pieces not removed. No power supply to motor.	Remove all packing pieces. Check that power supply is in order. Check lead connections. If necessary clean and re-align connections. Make certain leads are secure. See Page 12 for proper installation.
Speed consistently fast or slow (960 only).	Belt not attached properly. Incorrect motor pulley.	Replace with the correct motor pulley for the frequency in your area.
Speed variation—(Wow or flutter)	Warped record when playing a stack. Grease or oil on driving surfaces, belt, etc.	Play singly. Wipe with a clean lint-free cloth.
No Sound	Incorrect or defective cabling. Defective pickup cartridge.	Check cabling instructions Page 8. Have dealer check cartridge.
Low humming sound	Ground lead disconnected. Cartridge ground strap not removed.	Check cabling and ground lead connection. See Page 8. Remove ground strap.
Distorted sound	Worn, damaged or incorrect stylus. Dust on records, or stylus affected by fluff.	Replace stylus if necessary. Check stylus force. Handle and clean records as recommended by the manufacturers. Carefully remove any dust or fluff build-up from around stylus.
Tonearm lowers to incorrect position.	Cartridge out of position. Pickup stylus out of position. Lowering mechanism out of adjustment.	Check its position with setting gauge, Page 6. Reset or replace stylus. Adjust lowering position in accordance with instructions, Page 11.
Tonearm lifts too high.	Tonearm lifting height adjustment incorrectly set.	Adjust height in accordance with instructions, Page 12.
Tonearm will not lower to record at any time, or will not track properly.	Stylus force too low.	Adjust settings of counterbalance weight and pickup stylus force in accordance with instructions, Page 7.
Tonearm will not lower for automatic use after manual play.	Cue control is in "up" position.	Move control back to "down" position.
Tonearm will not rise from its rest.	Arm locked to its rest.	Move locking lever to free tonearm.
Records do not drop.	Auto spindle not properly in place.	Check Page 10 for correct installation.

B·I·C™ Multiple Play Manual Turntables

Owner's Manual
Belt Drive | Models 980 and 960

IMPORTANT AMENDMENT

- 1 This unit has been fitted (at the factory) with a new "Plug In" record support post. The diagram below explains its installation.



Installing Plug-In Record Platform

Each B-I-C 960 and 980 contains a plug-in record platform supplied in the styrofoam filler. The record platform contains a pin which mates with a keyway in the record platform socket located in the left-hand, rear portion of the unit. Locate the pin in the keyway and press the record platform firmly down until it locates in a positive manner. When playing records manually, the record platform can be removed or left in place.

- 2 This unit has also been fitted with a new low-mass cartridge head. Disregard all pictures that may refer to the old part. The mounting instructions remain the same.

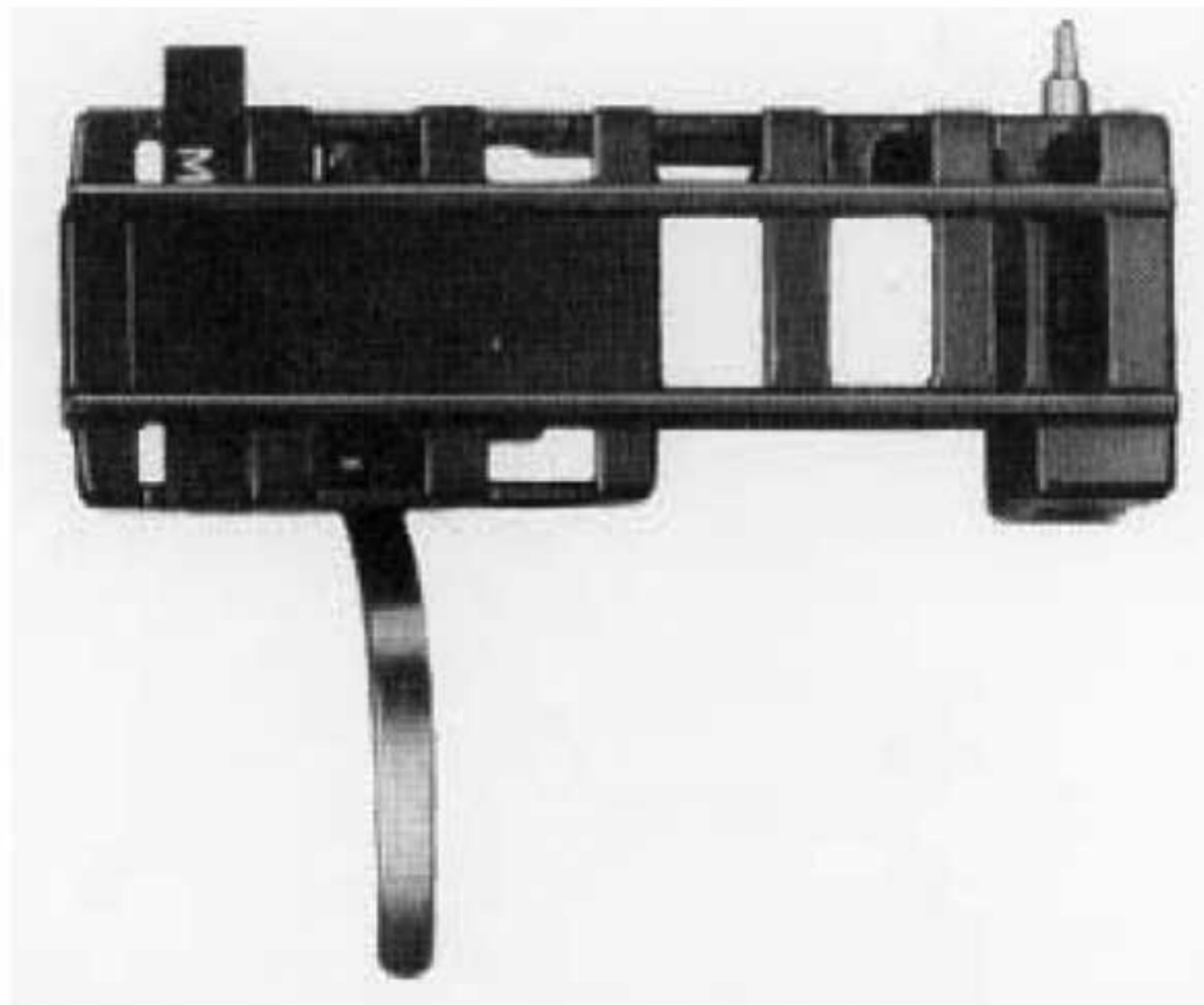

BRITISH INDUSTRIES COMPANY, Westbury, N.Y. 11590 | Division of Avnet, Inc.



BRITISH INDUSTRIES COMPANY, Westbury, N.Y. 11590 U.S.A. | Division of Avnet, Inc.

B-I-C is a trademark of British Industries Co., Westbury, N.Y. 11590. Division of Avnet, Inc. Copyright 1976. 
Specifications subject to change without notice.
28-498-04

1/76/4