

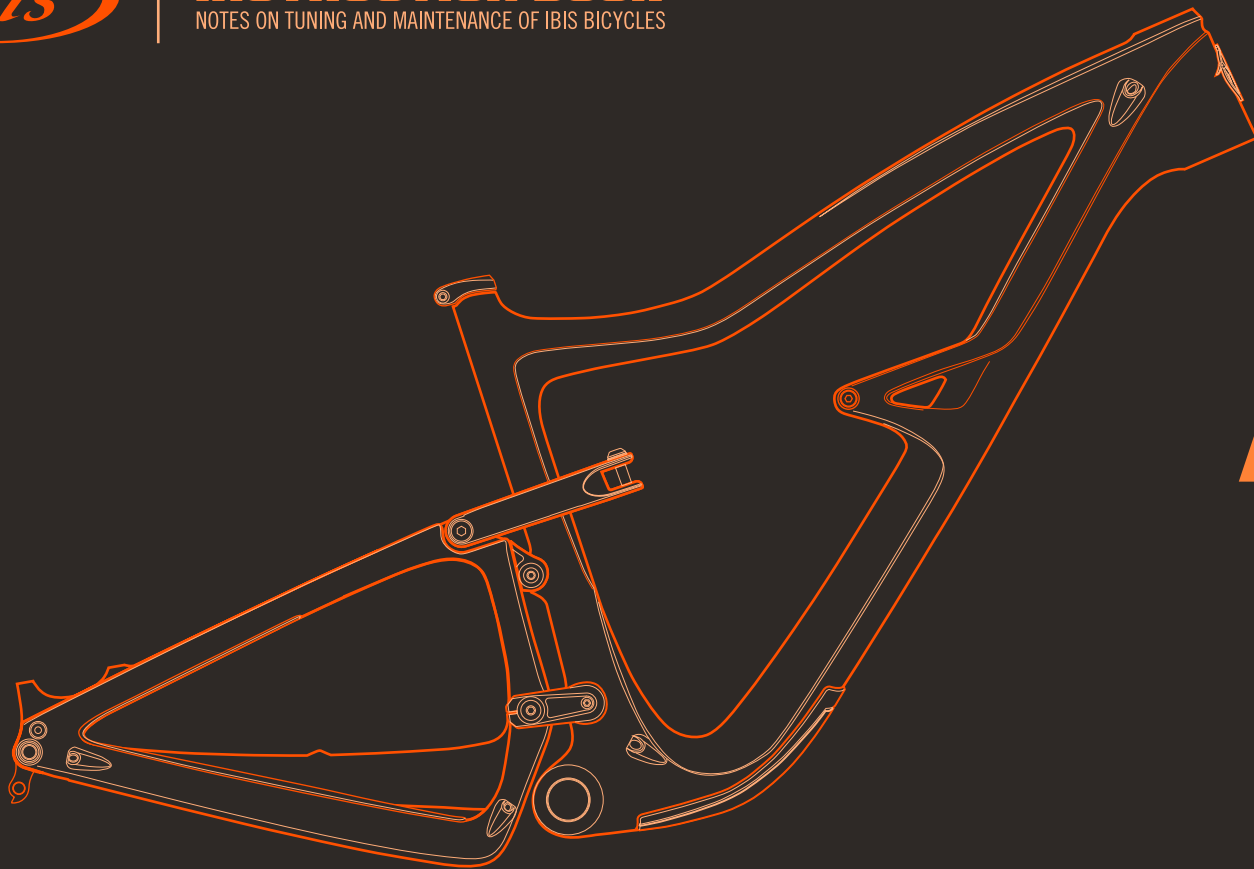

# **INSTRUCTION BOOK**

NOTES ON TUNING AND MAINTENANCE OF IBIS BICYCLES



**REV. J**



***INSTRUCTION MANUAL***

Notes on Tuning and Maintenance of Ibis Bicycles : Rev. J

Reprinting Permitted if Source Quoted

## SALUTATIONS

This Set-Up Guide will help you with assembly tips, get you started on adjusting the suspension, maintaining your frame and explain how to perform basic mechanical jobs.

This guide does not attempt to address full bike assembly, fitting, brake and shifting set-up, riding techniques etc. Please utilize a professional level service for these items to get the best performance and enjoyment from your Ibis.

**This Set-Up Guide is also available online with enhanced functions and additional information:**

[https://www.ibiscycles.com/support/set-up\\_guide](https://www.ibiscycles.com/support/set-up_guide)

**Information on legacy Ibis models available at:**

[http://www.ibiscycles.com/bikes/past\\_models](http://www.ibiscycles.com/bikes/past_models)

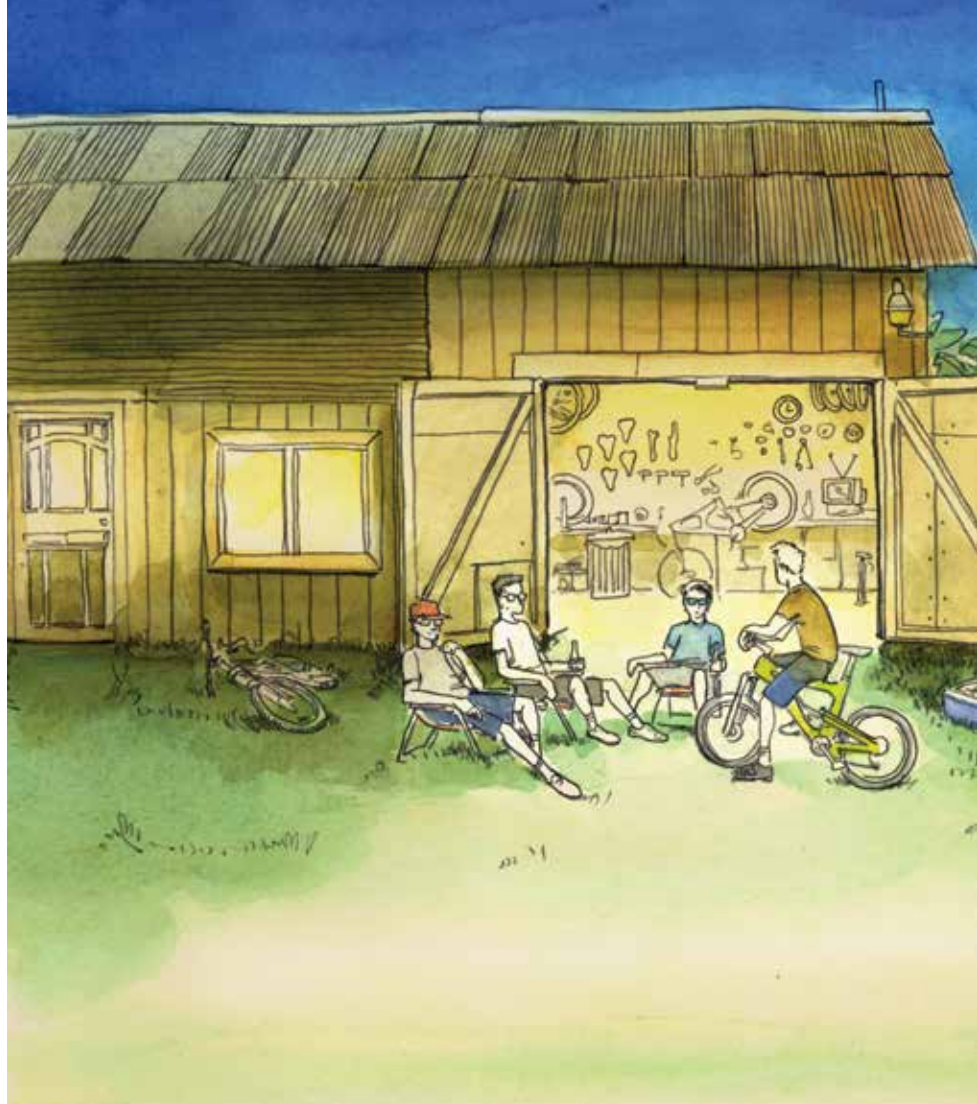



<b>INTRODUCTION</b>	2
<b>BUILD</b>	
Geometry / Quick Specs	4-6
Frame Sizing Guide	8-9
Bike Set-Up Tips and Tricks	10-36
<b>RIDE</b>	
Fork Set-Up	38-45
Fork Air Pressure Charts	40
Rear Shock Set-Up	46-51
Rear Shock Air Pressure Charts	50
<b>MAINTAIN</b>	
Bearing/Bushing Maintenance and Replacement	52-53
Frame Hardware (Part Numbers and Exploded Views)	54-57
Torque Specs	58-59
Swingarm Removal	60-63
<b>WARRANTY/REGISTRATION</b>	
Warranty	64-65
Serial Number	65
Documentation	65
<b>EXTRAS</b>	
Chuck's Recipe	68
Contact Info	67

**GEOMETRY / QUICK SPECS**

**RIPMO**

SIZE		SMALL	MEDIUM	LARGE	X-LARGE
SEATTUBE	A	14.5"	14.5"	16.5	18.5"
TOPTUBE	B	573mm	603mm	632mm	655mm
HEADTUBE	C	90mm	100mm	110mm	120mm
CHAINSTAY	D	435mm	435mm	435mm	435mm
SEAT ANGLE	E	77°	76°	76°	76°
HEAD ANGLE	F	65.9°	65.9°	65.9°	65.9°
WHEELBASE	G	1177mm	1195mm	1220mm	1249mm
STACK		613mm	620mm	629mm	642mm
REACH		431mm	446mm	471mm	493mm
STANDOVER		705mm	750mm	750mm	760mm
BB DROP		29mm	29mm	29mm	29mm
SADDLE HEIGHT FOR SEATTUBE ANGLE		650mm	700mm	750mm	800mm

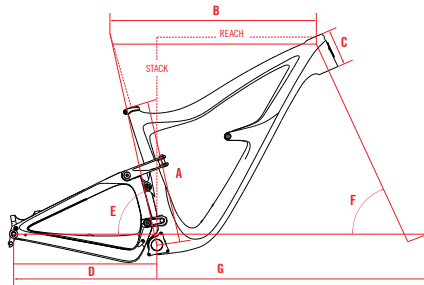

- 29" wheels
- 145mm rear wheel dw-link travel
- Approved for 160mm forks, 44mm rake (STRONGLY recommended)
- 65.9° head angle with a 160mm fork
- Cable routing through continuous internal tubes
- Chainstay length: 17.1"
- Threaded bottom bracket (73mm English thread)
- ISCG 05 compatible with optional removable adapter
- Tapered headtube and steerer: ZS44 upper, ZS56 lower
- 12 x 148mm BOOST rear axle
- 160mm post mount rear brake

**RIPMO AF**

SIZE		SMALL	MEDIUM	LARGE	X-LARGE
SEATTUBE	A	14"	15"	16.5"	18.5"
TOPTUBE	B	573mm	603mm	632mm	655mm
HEADTUBE	C	90mm	100mm	110mm	120mm
CHAINSTAY	D	435mm	435mm	435mm	435mm
SEAT ANGLE	E	77°	76°	76°	76°
HEAD ANGLE	F	64.9°	64.9°	64.9°	64.9°
WHEELBASE	G	1185mm	1216mm	1237mm	1262mm
STACK		613mm	620mm	629mm	642mm
REACH		431mm	458mm	475mm	495mm
STANDOVER		705mm	750mm	750mm	760mm
BB DROP		30mm	30mm	30mm	30mm
SADDLE HEIGHT FOR SEATTUBE ANGLE		650mm	700mm	750mm	810mm

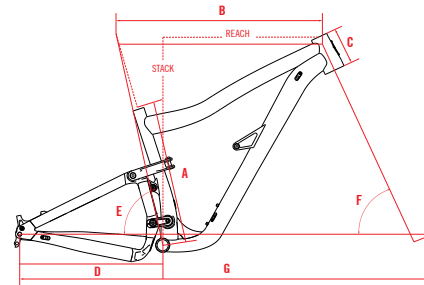

- 29" wheels
- 147mm rear wheel dw-link travel
- Approved for 160mm forks, 44mm rake (STRONGLY recommended)
- 64.9° head angle with a 160mm fork
- Super versatile internal cable routing
- Chainstay length: 17.1"
- Threaded bottom bracket (73mm English thread)
- ISCG 05 compatible with optional removable adapter
- Tapered headtube and steerer: ZS44 upper, ZS56 lower
- 12 x 148mm BOOST rear axle
- 160mm post mount rear brake

## RIPLEY

SIZE		SMALL	MEDIUM	LARGE	X-LARGE
SEATTUBE	A	14.5"	15"	16.5"	19"
TOPTUBE	B	574mm	603mm	630mm	658mm
HEADTUBE	C	90	105mm	115mm	125mm
CHAINSTAY	D	432mm	432mm	432mm	432mm
SEAT ANGLE	E	76°	76°	76°	76°
HEAD ANGLE	F	66.5°	66.5°	66.5°	66.5°
WHEELBASE	G	1147mm	1178mm	1207mm	1236mm
STACK		599mm	613mm	622mm	631mm
REACH		425mm	450mm	475mm	500mm
STANDOVER		708mm	712mm	742mm	755mm
BB DROP		38mm	38mm	38mm	38mm
SADDLE HEIGHT FOR SEATTUBE ANGLE		650mm	700mm	750mm	800mm

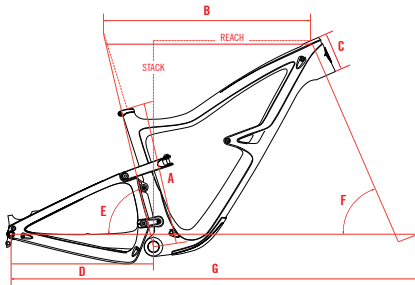

- 29" wheels
- 120mm rear wheel dw-link travel
- Approved for 120-140mm forks, 44mm rake (STRONGLY recommended)
- 66.5° head angle with a 130mm fork
- Cable routing through continuous internal tubes
- Chainstay length: 17"
- Threaded bottom bracket (73mm English thread)
- ISCG 05 compatible with optional removable adapter
- Tapered headtube and steerer: ZS44 upper, ZS56 lower
- 12 x 148mm BOOST rear axle
- 160mm post mount rear brake

## MOJO HD4

SIZE		SMALL	MEDIUM	LARGE	X-LARGE
SEATTUBE	A	14.25"	15.5"	17.6"	19"
TOPTUBE	B	579mm	604mm	628mm	658mm
HEADTUBE	C	87mm	109mm	126mm	142mm
CHAINSTAY	D	430mm	430mm	430mm	430mm
SEAT ANGLE	E	74°	74°	74°	74°
HEAD ANGLE	F	64.9°	64.9°	64.9°	64.9°
WHEELBASE	G	1163mm	1192mm	1219mm	1251mm
STACK		570mm	590mm	605mm	620mm
REACH		415mm	435mm	455mm	480mm

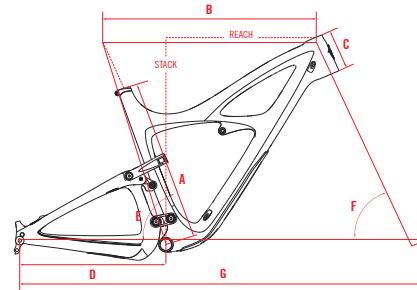

- 650b (27.5") wheels
- 153mm rear wheel dw-link travel
- Approved for 150-160mm forks
- 64.9° head angle with a 160mm fork
- Super versatile internal cable routing
- Chainstay length: 16.9"
- Threaded bottom bracket (68mm English thread)
- ISCG 05 compatible with removable adapter
- Tapered headtube and steerer, ZS44 upper, ZS56 lower
- 12 x 148mm BOOST rear axle
- 160mm post mount rear brake

## GEOMETRY / QUICK SPECS

## MOJO 3

SIZE		SMALL	MEDIUM	LARGE	X-LARGE
SEATTUBE	A	14.4"	16.9"	18.7"	20.5"
TOPTUBE	B	580mm	600mm	620mm	640mm
HEADTUBE	C	85mm	105mm	117mm	132mm
CHAINSTAY	D	425mm	425mm	425mm	425mm
SEAT ANGLE	E	74.6°	73.6°	73.6°	73.6°
HEAD ANGLE	F	66.8°	66.8°	66.8°	66.8°
WHEELBASE	G	1126mm	1137mm	1158mm	1180mm
STACK		578mm	592mm	602mm	616mm
REACH		419mm	423mm	438mm	455mm
STANDOVER		676mm	712mm	724mm	754mm
BB DROP		21mm	21mm	21mm	21mm
SADDLE HEIGHT FOR SEATTUBE ANGLE		600mm	720mm	787mm	807mm

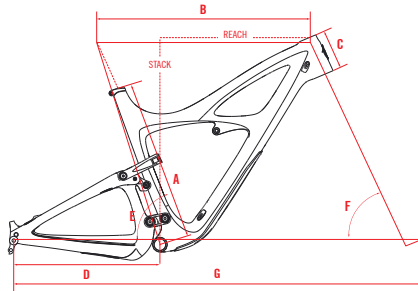

- 650b (27.5") wheels
- 130mm rear wheel dw-link travel
- Best with 140mm forks
- 66.8° head angle with a 140mm fork
- Super versatile internal cable routing
- Chainstay length: 16.7"
- Threaded bottom bracket (68mm English thread)
- ISCG 05 compatible with optional removable adapter
- Tapered headtube and steerer, ZS44 upper, ZS56 lower
- 12 x 148mm BOOST rear axle
- 160mm post mount rear brake

## DV9

SIZE		SMALL	MEDIUM	LARGE	X-LARGE
SEATTUBE	A	14.5"	17"	19"	21"
TOPTUBE	B	582mm	607mm	628mm	658mm
HEADTUBE	C	92mm	110mm	116mm	133mm
CHAINSTAY	D	439mm	439mm	439mm	439mm
SEAT ANGLE	E	73°	73°	73°	73°
HEAD ANGLE	F	68.5°	68.5°	68.5°	68.5°
WHEELBASE	G	1100mm	1126mm	1147mm	1182mm
STACK		611mm	628mm	634mm	649mm
REACH		397mm	418mm	435mm	462mm
STANDOVER		687mm	757mm	757mm	782mm
BB DROP		64mm	64mm	64mm	64mm

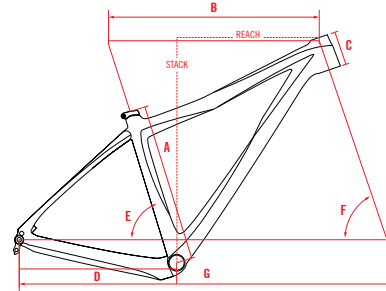

- 29" wheels
- Approved for 100-120mm forks, 51mm rake (STRONGLY recommended)
- 68.5° head angle with a 100mm fork
- 67.4° head angle with a 120mm fork
- Super versatile internal cable routing
- Chainstay length: 439mm
- Threaded bottom bracket (73mm English thread)
- Tapered headtube and steerer: ZS44 upper, EC49 lower
- 12 x 148mm BOOST rear axle
- 160mm post mount rear brake

# HAKKA MX

SIZE		49	53	55	58	61
SEATTUBE	A	455mm	525mm	550mm	575mm	605mm
TOPTUBE	B	520mm	540mm	550mm	570mm	590mm
HEADTUBE	C	110mm	135mm	155mm	175mm	195mm
CHAINSTAY	D	430mm	430mm	430mm	430mm	430mm
SEAT ANGLE	E	74.5°	73.5°	73.5°	73.5°	73.5°
HEAD ANGLE	F	70.5°	71.5°	72°	72°	72°
WHEELBASE	G	1007mm	1011mm	1021mm	1037mm	1057mm
STACK		532mm	560mm	580mm	599mm	616mm
REACH		370mm	373mm	382mm	391mm	406mm
STANDOVER		729mm	785mm	802mm	827mm	853mm
BB DROP		70mm	70mm	70mm	70mm	70mm

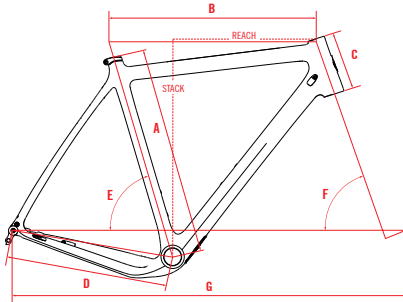

- 700c or 650b (27.5") wheels
- Trail: 67mm @ 71.5° head angle, 70mm @ 71° and 73mm @ 70.5°
- Super versatile internal cable routing, Di2 compatible
- T47 bottom bracket
- 700x40c BB Height: 283mm
- 700x33c or 27.5x2.1" BB Height: 277mm
- 34.9mm bottom pull front derailleur
- Tapered headtube: IS41 upper, IS52 lower
- 142x12mm rear dropout spacing
- 140mm flat mount rear (160mm max rotor)

**FRAME SIZING GUIDE****MOUNTAIN BIKE SIZING GUIDE**

FRAME SIZE	HEIGHT / IN	HEIGHT / CM
SMALL	5'0" – 5'5"	152 – 165
MEDIUM	5'4" – 5'9"	163 – 175
LARGE	5'8" – 6'1"	173 – 186
X-LARGE	6'0" – 6'6"	183 – 198



**HAKKA MX SIZING GUIDE**

FRAME SIZE	HEIGHT / IN	HEIGHT / CM
49	5'0" – 5'4"	152 – 163
53	5'3" – 5'8"	160 – 173
55	5'7" – 5'11"	170 – 180
58	5'10" – 6'2"	178 – 188
61	6'1" – 6'6"	185 – 198



**BIKE SET-UP TIPS AND TRICKS****RIPMO/RIPMO AF/RIPLEY***Driveside Cable Routing*

For cable routing, the Ripmo / Ripley features carbon fiber tubes molded inside the frame.

Just push the housing through and it pops out the other end. Simple! And quiet too.

The Ripmo AF cables are routed similarly but there are no tunnels and use our versatile cable ports.

**RIPMO/RIPMO AF/RIPLEY**  
*Non-Driveside Cable Routing*

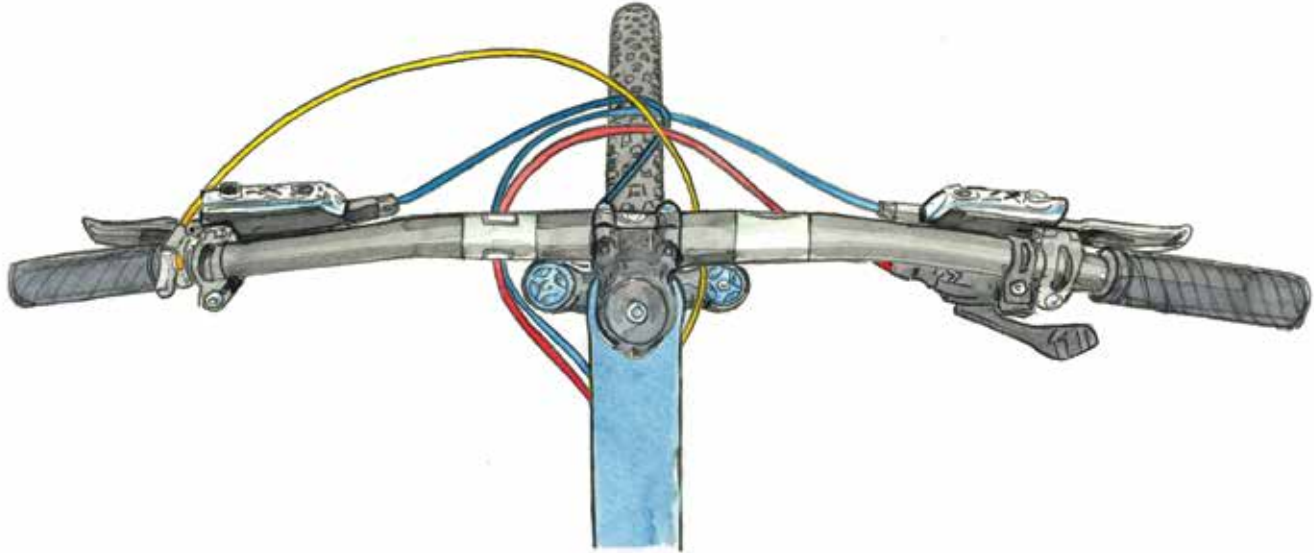

**IMPORTANT:** Before riding the Ripmo / Ripmo AF, check the saddle to tire clearance with the dropper post fully dropped and the air out of the shock with frame compressed to bottom out.

**BIKE SET-UP TIPS AND TRICKS****RIPMO/RIPMO AF/RIPLEY***1x Cable Routing*

**RIPMO/RIPMO AF/RIPLEY**  
*Front Cable Routing*

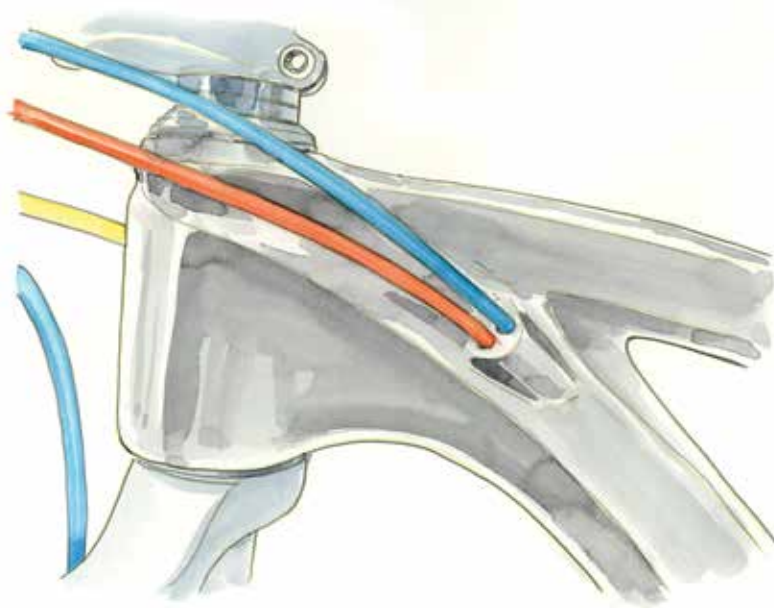

**NOTE:** The Ripmo AF uses our cable ports in this location.

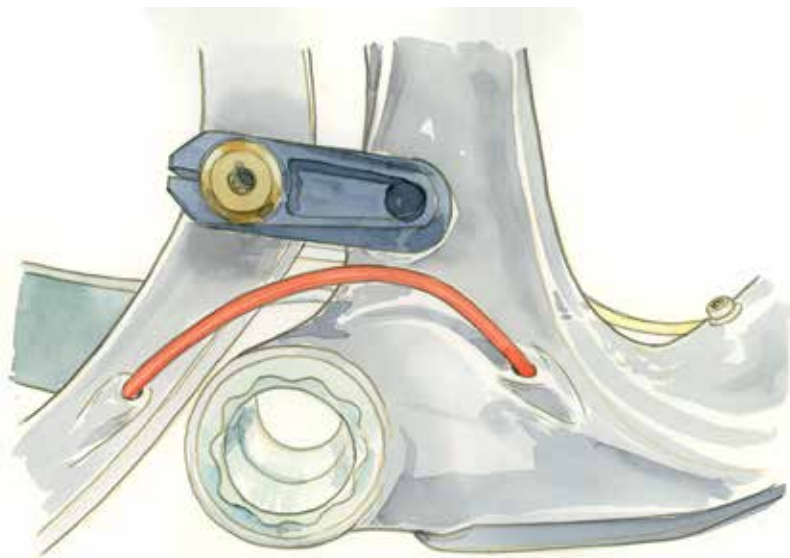
**BIKE SET-UP TIPS AND TRICKS****RIPMO/RIPMO AF/RIPLEY***Driveside Cable Routing*

**NOTE:** The Ripmo AF uses a cable port to exit the down tube, then you run uninterrupted cable to the rear derailleur, from the front of the chainstay and exiting via the port at the end of the chainstay.

**RIPMO/RIPMO AF/RIPLEY**  
*Non-Driveside Cable Routing*

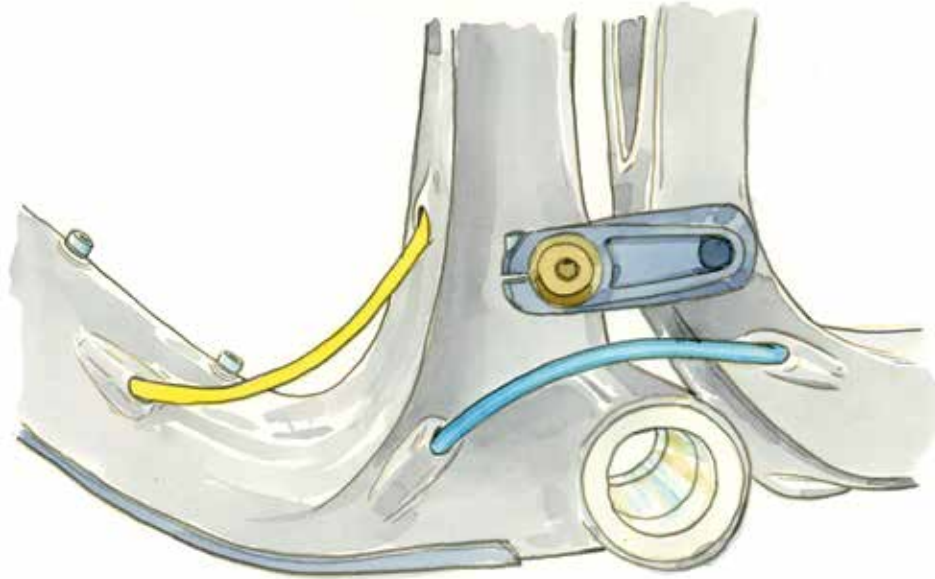

**NOTE:** The Ripmo AF uses a hydro cable port to exit the down tube, then you run the brake line on top of the chainstay back to the caliper.

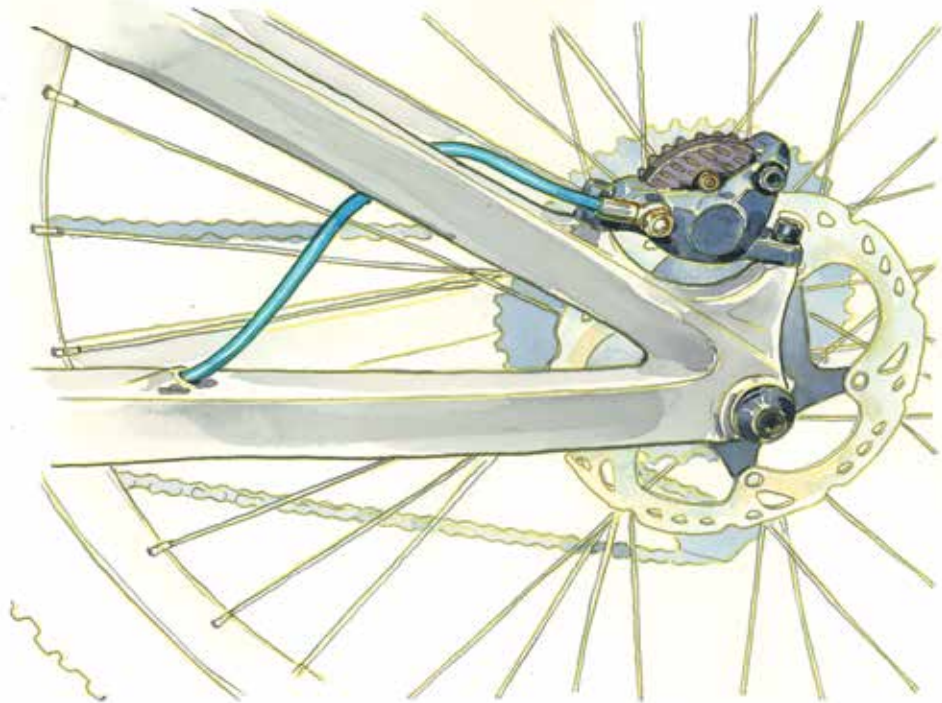
**BIKE SET-UP TIPS AND TRICKS****RIPMO/RIPMO AF/RIPLEY***Brake Cable Routing*

### **MOJO HD4 AND RIPMO/RIPMO AF/RIPLEY CHAIN GUIDE**

For the Ripmo, Ripmo AF, Ripley, Mojo HD4, and Mojo 3 we manufacture a removable ISCG 05 mount which mounts on the splines on the drive side of the bottom bracket. Standard procedures apply to mounting an ISCG 05 compatible chain guide or bash guard.

**If you need an ISCG 05 adapter, it's available in our online store:**

<http://store.ibiscycles.com> and search **ISCG**.

### **CHAIN LENGTH**

To determine the correct chain length: shift into the large chainring and largest cog and let all the air out of your shock (on suspension bikes only, duh).

Thread the chain through the gears and derailleurs, compress the suspension all the way to bottom out, and cut the chain at the minimum length needed with the rear derailleur stretched out.

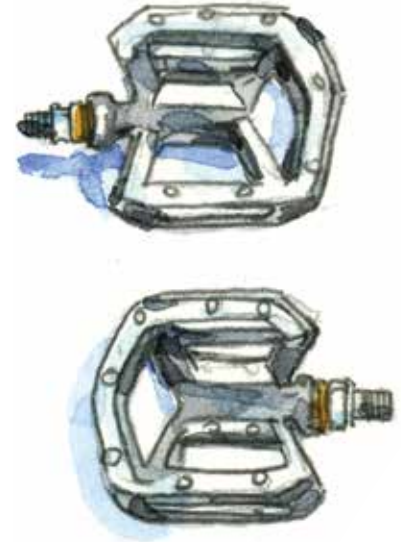

**BIKE SET-UP TIPS AND TRICKS****MOJO HD4/MOJO 3**  
*Driveside Cable Routing*

The Mojo HD4 / Mojo 3 uses our versatile cable port system for cable routing. We have several port styles available, depending on your drivetrain and dropper configuration.

**MOJO HD4/MOJO 3**  
*Non-Driveside Cable Routing*

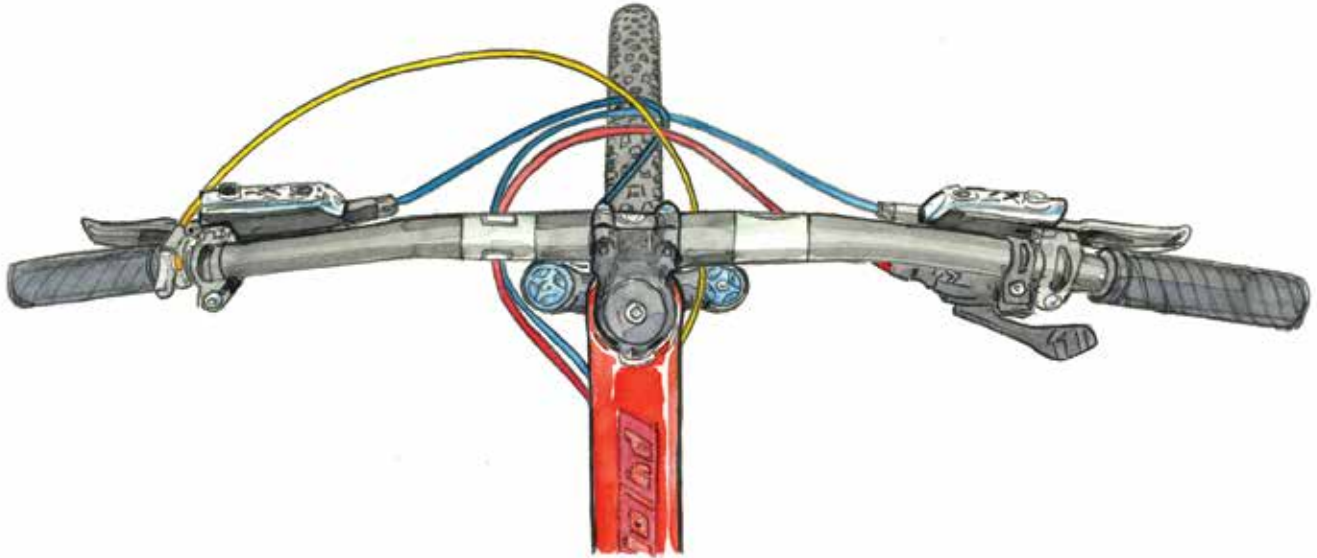

The most common set-up these days is a 1X drivetrain with an internally mounted dropper. We spec the Bike Yoke Revive or KS E30i, depending on the group. We recommend you run your brake on the exterior, along the left side of the down tube.

**BIKE SET-UP TIPS AND TRICKS****MOJO HD4/MOJO 3**  
*1x Cable Routing*

2X routing on the Mojo 3 is the same as the DV9 as shown on [page 26](#).

### MOJO HD4/MOJO 3 Derailleur Cable Routing

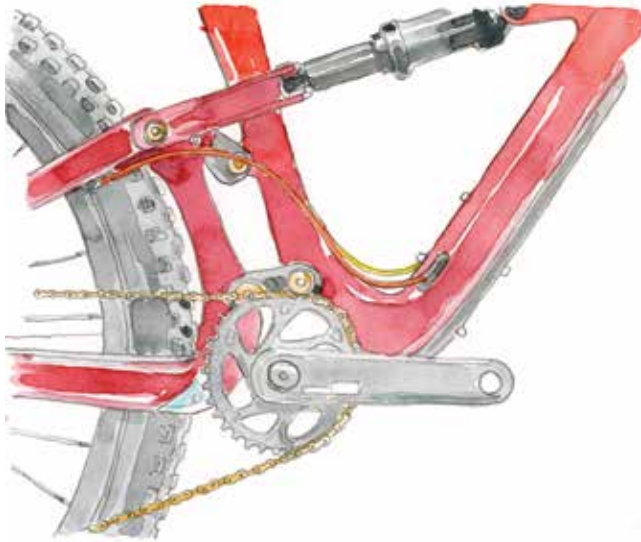

#### **A NOTE ON MOJO 3 ROUTING WITH TOP PULL DERAILLEURS**

We have made the Mojo 3 compatible with the new Shimano side swing front derailleurs. Should you be retrofitting an older style top pull derailleur refer [page 22](#) in our December 2018 Setup Guide: [https://www.ibiscycles.com/support/set-up\\_guide/](https://www.ibiscycles.com/support/set-up_guide/)

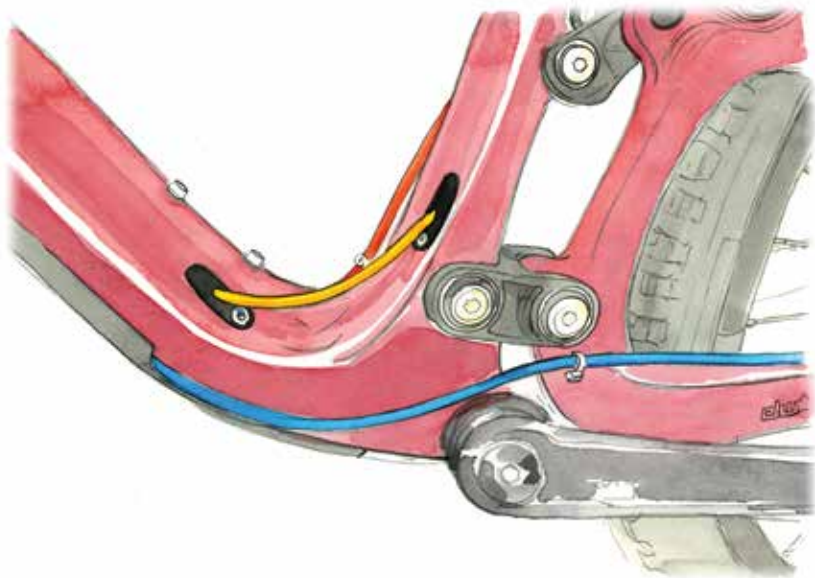

**MOJO HD4/MOJO 3***Dropper Cable Routing*

---

**A NOTE ON REVERB DROPPER ROUTING**

The Reverb dropper routing we prefer is not illustrated, but we'll describe it for you. You need three of our hydro cable stops. Route the Reverb into the left side of the down tube (it's a single port) using our hydro port. Use two other hydro ports at the bottom left side of the down tube and seat tube, and fish the dropper tubing through to the seat tube. Connect as normal.

If you're using Shimano's new side pull front derailleur, route it through the drive side of the down tube and then out at the bottom of the drive side. For top mount front derailleurs use the toptube for entry and exit for the derailleur cable. Note that you have the choice of full housing or interrupted derailleur housing with our versatile port configurations.

For droppers that use cable and housing, such as the KS LEV, route the housing according to the illustrations.

**Minimum and maximum dropper insertion charts** can be found under the geometry link on each model's webpage over at [ibiscycles.com](http://ibiscycles.com)

---

**MOJO HD4/MOJO 3**  
*Brake Cable Routing*

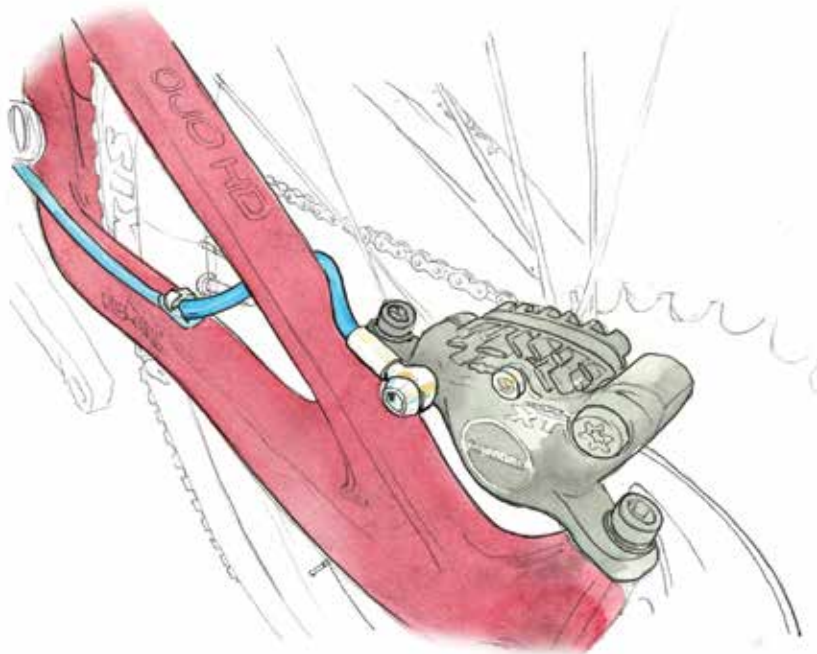



**DV9**  
*Non-Driveside Cable Routing*

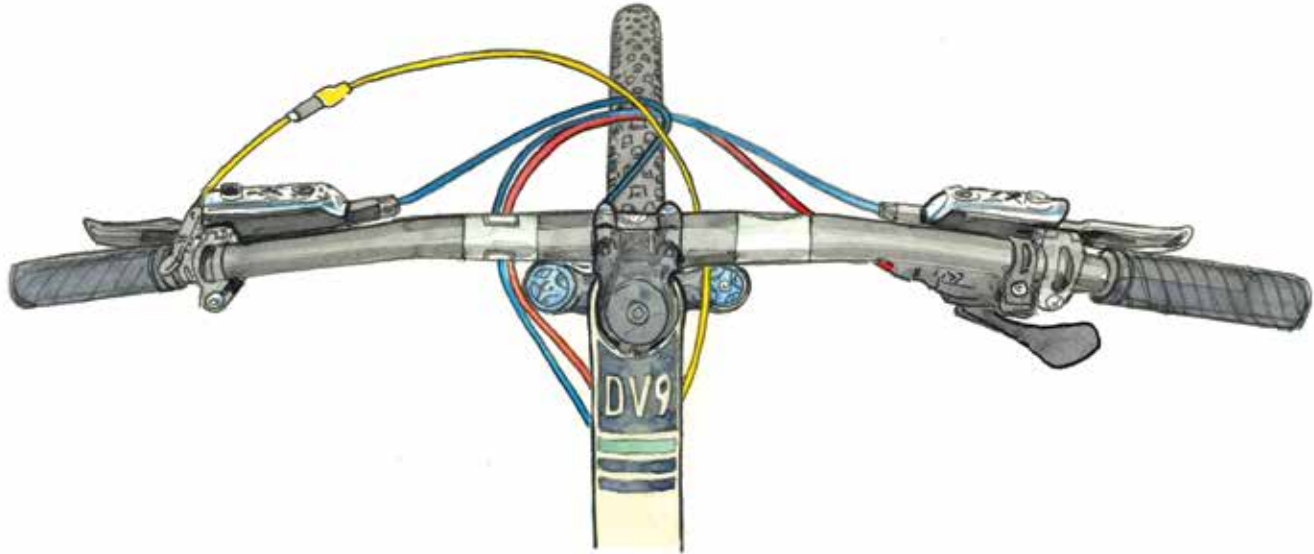

**BIKE SET-UP TIPS AND TRICKS****DV9**  
*1x Cable Routing*



*Dusk in the  
Marin Headlands*

*DV9 San Francisco CA*

## BIKE SET-UP TIPS AND TRICKS

### HOW TO ROUTE THE HAKKA MX FRONT DERAILLEUR CABLE THROUGH THE BOTTOM BRACKET

- The bike came with a noodle (in the bag of stuff), you'll need that.
- Feed a shift wire (an old one) through the noodle so the the cable nub is stuck in the open end (where housing would fit in)
- Feed the bare end of the cable through the cable stop from the inside so that it exits out the frame along the seat tube. This is the trickiest part, it helps to put a little kink in the end of the cable
- Pull the cable all the way out the port so that it is pulling the cable noodle into the cable stop. Use a fourth hand tool to pull on the cable and massage the noodle so that it is firmly placed in the cable stop (should be a snug fit). Once it is in place in the cable stop, leave it there!
- Once the noodle is in the cable stop, remove the cable and route your cable housing from the front shifter to the noodle (internal to the down tube). The end of the noodle should be accessible from the bolt-on door underneath the down tube.
- Feed your shift cable from the shifter, through your housing, into the noodle, and out to the front derailleur. If the cable catches on the cable stop upon exiting the noodle, it may help to add a kink to the end of the cable.

### CAN I PUT A FOX AX FORK ON MY HAKKA?

The Fox AX fork will only fit on the 55cm frame. It will touch the down tube on all other frame sizes. It also impacts the geometry in a negative manner, making the angles too slack. In other words, we do not recommend it.

### CAN I PUT A REAR RACK ON MY HAKKA MX?

The Hakka MX is not rear rack compatible. The eyelets on the stays are for fenders. The seat stays are not designed to withstand the forces of a rack. For bikepacking, we recommend something similar to the illustration over to the right.

### BB DRAIN ON HAKKA

The Hakka MX is intended to have a small hole drilled in the bottom of the bottom bracket shell. Some of them don't, and if you ride in wet conditions, water could accumulate in your bottom bracket. It's simple to check, just look under your bottom bracket shell. If there's no hole, simply use a 2mm or thereabouts drill and gently drill through the aluminum shell.

### HAKKA MX Di2 CABLING INSTRUCTIONS

Here's what each wire length is intended to connect:

**1200mm:** Connects A junction box (at stem) to B junction box (inside down tube)

**900mm:** Connects B junction box to rear derailleur (routes through right chainstay)

**2x400mm:** connects right and left shifters to A junction box. The left shifter is not necessary, but we include it anyway in case you want right-up/left-down type shifting

**350mm:** Connects battery (zip-tied to down tube battery door) to B junction box.

Try to attach the B junction box to the battery so that it isn't rattling loose inside the down tube. Another option would be to wrap it in foam so that it doesn't make any sound as it bounces around.

Here's how you mount the battery to the battery door.





DEADMANS HILL

ELE. 10,269 FEET



*Rambling through North Park  
Hakka MX, Colorado*

## BIKE SET-UP TIPS AND TRICKS

### CABLE ROUTING PORTS

On all bikes except the Ripmo and Ripley, we now have plastic ports that play nicer with your cable housing. They include the most popular ones: single stop and single port, double port and double port/stop. Parts that will remain metal are single blank, single Di2, double Di2, and single Reverb port.



There are dozens of possible port/routing combinations on our bikes. For the latest port availability, go to our online store and search for **port**: <http://store.ibiscycles.com>



### MOTO FRONT BRAKE ROUTING

#### RIPLY AND RIPMO / AF

Put the rear brake in the dropper hole (right side of down tube) and the dropper in the brake hole (left side). They both come out on the same side of the BB so you can plug them in to their correct segments after that.

#### MOJO 3, HD4, DV9

We recommend you route the rear brake line directly from the lever on the left-hand side of the handlebar to the left side of the down tube, attaching it using existing guides. The line will have a slightly tighter radius than it would otherwise but that is OK. Be sure to leave sufficient line so the handlebars can rotate in the event of a crash. If necessary, use clear adhesive dots to prevent the line rubbing on the headtube.

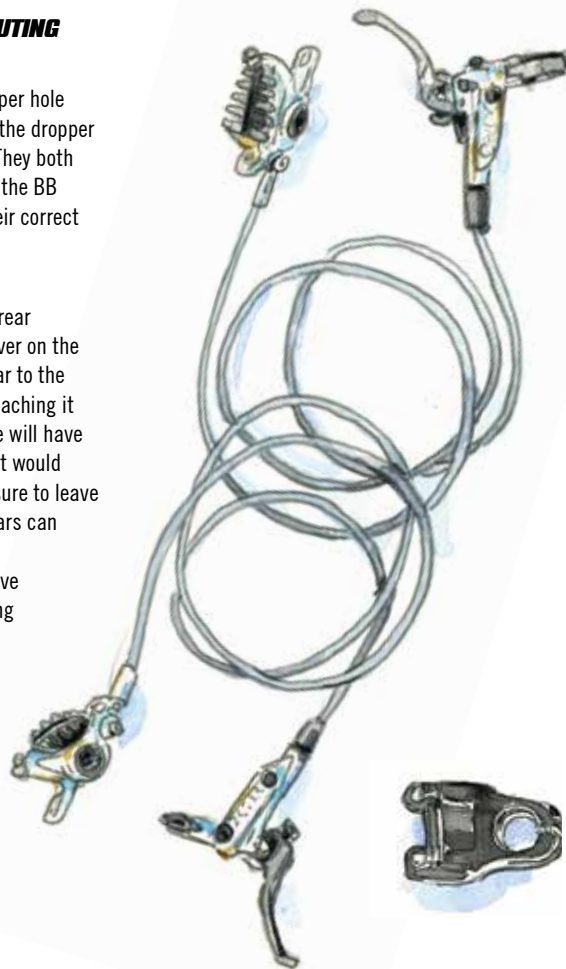



*"Hello" from Gold Country*

*Ripmo in Downierville, CA*

## BIKE SET-UP TIPS AND TRICKS

### NOTE ON BOOST MOJO HD4/MOJO 3 BOTTOM BRACKET INSTALLATION

The profile of the carbon swingarm on the BOOST Mojo HD4 and Mojo 3 rear triangle is wider so it interferes with the bottom bracket (BB) tool when the swingarm is in the top out position.

The BB cup on the non-drive side of the rear triangle is very close to the swingarm. When installing the BB care should be given to not scratch up or otherwise damage the frame.

We recommend using only a socket type BB installation tool from your preferred bike tool manufacturer.

On the Mojo 3, you can gain some extra room by deflating the shock and moving the swingarm to the bottom out position.

YES



NO



### WIDE RIMS

In 2014, we introduced our line of wide carbon fiber rims and wheels.

Wide rims support the tire's sidewalls better, allowing lower pressures without the tires folding over or burping. This dramatically increases stability and traction. This shows up as faster cornering and braking, better grip in all conditions.

The low system weight of the wheels with these rims and tires combined with the monstrous traction advantage have been a revelation for those who have ridden them.

Our carbon wheels now come with the excellent Industry Nine Hydra hubs. The durable hubs are made in the USA in Industry Nine's Asheville machine shop with an incredible .52° engagement. They are equipped with Enduro bearings and come with either Shimano or SRAM XD drivers.

You can read all about our new rim and wheel technology at:

<http://www.ibiscycles.com/wheels/>

### PLUS TIRES

If you take a straw poll of the folks at Ibis, we've settled on 2.6" as being the sweet spot for overall performance and traction in the 27.5 and 29" wheel platforms.

The Mojo 3 and the Mojo HD4 are also compatible with tires up to 2.8". Either of these tire sizes combined with our ultra wide aluminum and carbon fiber rims provide elbow-dragging traction. Which is good.

The new S35 (and previous generation 742/942/738/938) rims are ideal for the ultra low pressures (10-18 psi) that we like to run with 2.6 and 2.8 Plus tires (or 18-25psi for 2.25" - 2.5" tires). Any of our 35mm internal width rims work incredibly well with the new wide rim friendly rubber we've been riding from Schwalbe, Maxxis and others.



## BIKE SET-UP TIPS AND TRICKS

	<b>CARBON i9</b>				<b>CARBON LOGO</b>				
<b>RIMS &amp; WHEELSETS</b>	<b>S35 / 27.5</b>	<b>S28 / 27.5</b>	<b>S35 / 29</b>	<b>S28 / 29</b>	<b>S35 / 27.5</b>	<b>S28 / 27.5</b>	<b>S35 / 29</b>	<b>S28 / 29</b>	<b>D30</b>
<b>WHEEL SIZE</b>	27.5"	27.5"	29"	29"	27.5"	27.5"	29"	29"	700
<b>OUTER WIDTH (MM)</b>	41	35	41	35	41	35	41	35	26
<b>INNER WIDTH (MM)</b>	35	28.6	35	28.6	35	28.6	35	28.6	19
<b>RIM WEIGHT (G)</b>	420	380	455	410	420	380	455	410	400
<b>RIM MATERIAL</b>	Toughened Hybrid Carbon				Toughened Hybrid Carbon				Carbon
<b>DRILLING</b>	32°				32°				24°
<b>TYPE</b>	Tubeless				Tubeless				Tubeless
<b>WHEELSET WEIGHT (G)</b>	1600	1530	1650	1580	1640	1570	1710	1630	1504
<b>SECTION HEIGHT</b>	18.3	18.3	18.3	18.3	18.3	18.3	18.3	18.3	30
<b>SPOKE OFFSET (MM)</b>	5	4	5	4	5	4	5	4	0
<b>SPOKES</b>	Sapim CX-Ray				Sapim D-Light				Sapim D-Light
<b>CROSS</b>	3				3				2
<b>SPOKE LENGTH (MM)**</b>	Front: 276ND / 275D, Rear: 275ND / 273D	Front: 296ND / 294D, Rear: 294ND / 292D			274	275	293	293	Front: 280ND / 278D, Rear: 278ND / 280D
<b>ERD (MM)</b>	566	564	604	602	566	564	604	602	583
<b>THRU AXLE OPTIONS</b>	15x110 / 148x12				15x110 / 148x12	15x110 / 148x12 12x100 / 142x12	15x110 / 148x12		12x100 / 142x12
<b>MAX RIM PRESSURE</b>	40				40				23mm: 120psi, 32mm: 80psi, 40mm: 70psi
<b>FEATURES</b>	5mm Asymmetric High Impact Carbon Stan's BST Mounting	4mm Asymmetric High Impact Carbon Stan's BST Mounting	5mm Asymmetric High Impact Carbon Stan's BST Mounting	4mm Asymmetric High Impact Carbon Stan's BST Mounting	5mm Asymmetric High Impact Carbon Stan's BST Mounting	4mm Asymmetric High Impact Carbon Stan's BST Mounting	5mm Asymmetric High Impact Carbon Stan's BST Mounting	4mm Asymmetric High Impact Carbon Stan's BST Mounting	Readily Accepts Tires from 23c to 42c
<b>HUBS</b>	<b>S35 / 27.5</b>	<b>S28 / 27.5</b>	<b>S35 / 29</b>	<b>S28 / 29</b>	<b>S35 / 27.5</b>	<b>S28 / 27.5</b>	<b>S35 / 29</b>	<b>S28 / 29</b>	<b>D30</b>
<b>BRAND</b>	Industry Nine Hydra				Ibis				Ibis
<b>FREEHUB MECHANISM</b>	6-Pawl, 6-Phase / 115-Tooth Drive Ring				4-Pawl / 36-Tooth Drive Ring				4-Pawl / 36-Tooth Drive Ring
<b>FREEHUB ENGAGEMENT</b>	.52° / 690 Points of Engagement (POE)				10°				10°
<b>DRIVER</b>	Sram XD Shimano Microspline Shimano 11 Spd.				Sram XD Shimano Microspline Shimano 11 Spd.	- - Shimano 11 Spd.	Sram XD Shimano Microspline Shimano 11 Spd.		- - Shimano 11 Spd.
<b>BEARINGS / QTY.</b>	Enduro / x4				Enduro / x4				Enduro / x4
<b>DISC ROTOR MOUNT TYPE</b>	Center Lock				6 Bolt				6 Bolt

\*ERD measured with Park sticks and using .25 mm thick nipple washers. \*\*D = Drive Side, ND = Non-Drive side

	<b>ALUMINUM LOGO</b>			
<b>RIMS &amp; WHEELSETS</b>	<b>S35 / 27.5</b>	<b>S35 / 29</b>	<b>733</b>	<b>933</b>
WHEEL SIZE	27.5"	29"	27.5"	29"
OUTER WIDTH (MM)	39	39	33	33
INNER WIDTH (MM)	35	35	29	29
RIM WEIGHT (G)	505	540	455	490
RIM MATERIAL	6061 Aluminum		6066 Aluminum	
DRILLING	32°			
TYPE	Tubeless			
WHEELSET WEIGHT (G)	1810	1880	1720	1820
SECTION HEIGHT	18.3	18.35	19.5	19.5
SPOKE OFFSET (MM)	5	5	2.5	2.5
SPOKES	Sapim D-Light			
CROSS	3	3	3	3
SPOKE LENGTH (MM)**	274	293	273	292
ERD (MM)	565	602	563	599
THRU AXLE OPTIONS	15x110 / 148x12		12x100 / 142x12	15x110 / 148x12
MAX RIM PRESSURE	40			
FEATURES	5mm Asymmetric Welded Black Ano / Laser Engraved Stan's BST Mounting		2.5mm Asymmetric Welded Black Ano / Laser Engraved Tool Free Tire Mounting	
<b>HUBS</b>	<b>S35 / 27.5</b>	<b>S35 / 29</b>	<b>733</b>	<b>933</b>
BRAND	Ibis			
FREEHUB MECHANISM	4-Pawl / 36-Tooth Drive Ring			
FREEHUB ENGAGEMENT	10°			
DRIVER	XD - Shimano 11 Spd.			
BEARINGS / QTY.	Enduro / x4			
DISC ROTOR MOUNT TYPE	6 Bolt			



## BIKE SET-UP TIPS AND TRICKS

### HEADSETS

The headset on the Ripmo, Ripley, Mojo HD4, and Mojo 3 is a ZS44/ZS56. This standard is compatible with both the Chris King InSet 2 and certain Cane Creek headsets.

Headset on the DV9 is the ZS44/EC49. This standard is compatible with both the Chris King InSet 3 and certain Cane Creek headsets.

The Hakka MX uses an IS41/IS52.

To learn more about these various headset standards, visit: [www.bicycleheadsets.com](http://www.bicycleheadsets.com).

### REAR DROPOUTS AND DISC BRAKE MOUNTS

All of our suspension bikes use the boost standard and our own Hexle axles.

They use a post-mount standard caliper mounted directly to the frame for a 160mm rotor or utilizing a post mount adapter for 180mm/185mm/200mm/203mm rotors.

### BOTTLE CAGE

Our rear suspension equipped bikes work best with a side loading cage, we like the Arundel side loader.

There are two sets of holes in the cage, use the ones that position it away from the seattube.

There are two heavy duty Riv-Nut inserts on the underside of the down tube of the Mojo 3, to allow the mounting of a bottle cage. We've put them there primarily for a spare water bottle, a tool kit

or for a battery if you're night riding. Do not put a large bottle under the down tube of a small Ripley, the front tire will hit it at bottom out.

Please do not attempt to retrieve a water bottle from this cage location during riding!

### GENERAL FRAME INFORMATION CARE FOR CARBON

The carbon fiber monocoque frame is extremely strong, and should provide years of trouble-free use, provided you care for it properly and don't overly huck every 50 foot gap you see.

Keep your bike clean and inspect it often. Although each and every bike gets tested at the factory for strength, it never hurts to look at the areas where the tubes join, where the shocks and dropouts mount and any other areas that may receive stress during usage. Check for loose bearings, headsets, shocks and forks and such. Visually inspect the bike before each ride and also during each cleaning.

### CARBON ASSEMBLY COMPOUND

This stuff is grease, but with a bunch of tiny plastic beads added. This increases friction between components, great for holding your carbon seat post or handlebars in place without excessive clamping force. While grease won't hurt any of our seattubes, carbon assembly paste works even better. Do not use the carbon assembly compound when installing the headset,

bottom bracket, shock, water bottle cage, or anything that has bearings.

### PAINT AND DECALS

Should you need to touch up areas of the frame where the paint has been compromised, we have touch up paint in our online store for several of our bikes: <http://store.ibiscycles.com> and search paint.

For colors not found in our store, we recommend either a hobby shop, [myperfectcolor.com](http://myperfectcolor.com) or [testors.com](http://testors.com) as a good source of enamel touch up paint.

We try to make our frame finishes as durable as possible, but it is impossible to test in all conditions and against all chemicals. Be aware that use of certain cleaners, lubricants, or foodstuffs, including Simple Green and Pedro's Bike Lust, may damage the paint. Please note that paint damage is not covered under the warranty. Clean any of our frames with mild soap and water only.



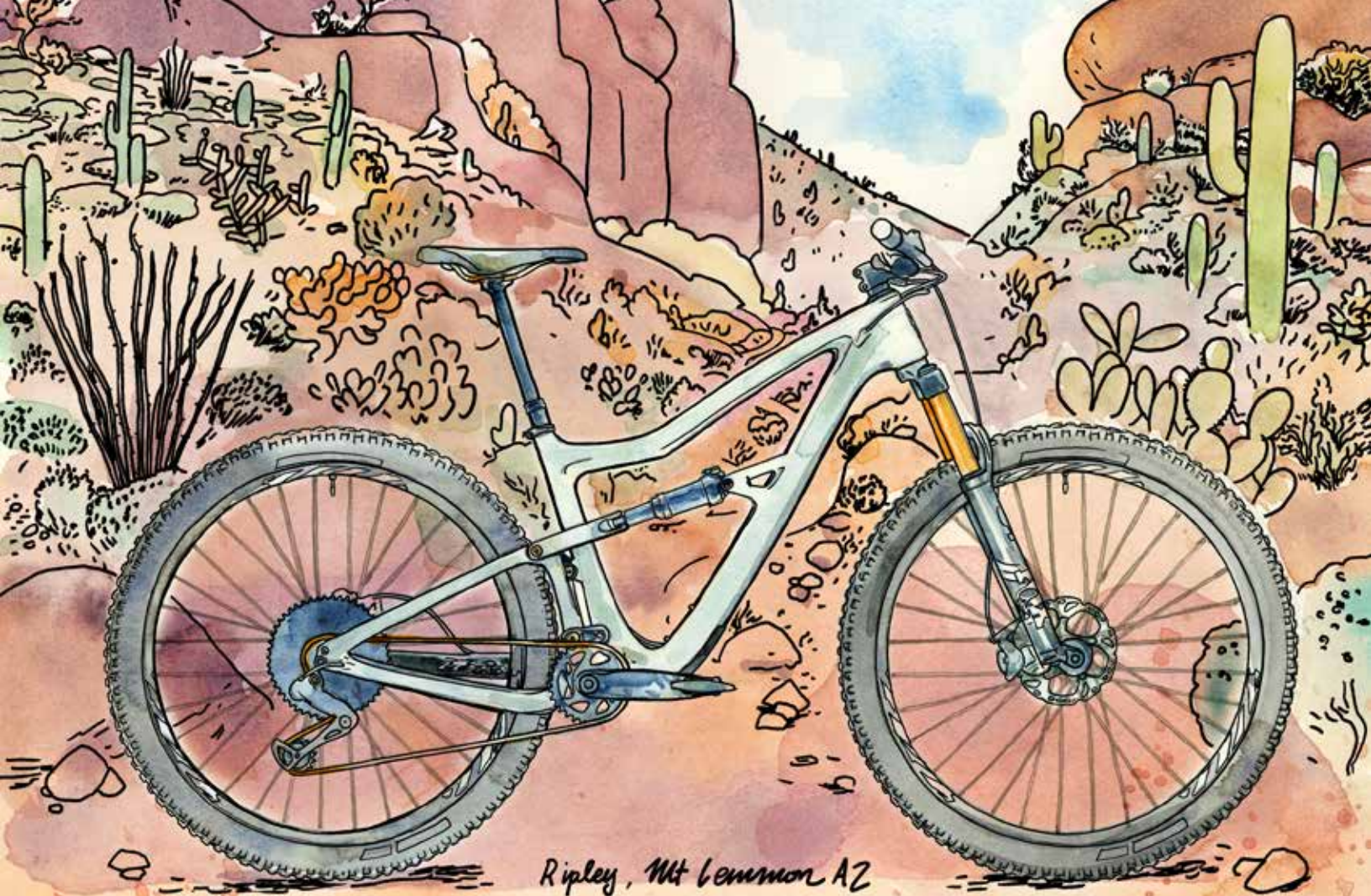

Ripley, Mt Lemmon AZ

## FORK SET-UP

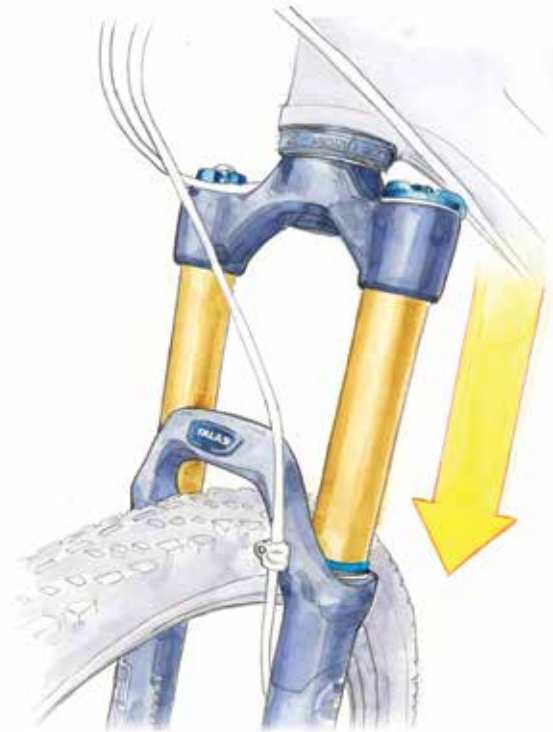
**SETTING SAG****STEP 1**

Add recommended air for rider weight (see charts on following pages). On any fork with a lever, make sure to set sag with the compression lever in the OPEN mode. With bike on level ground, bounce up and down a bit to overcome shock stiction. Settle into your riding position.

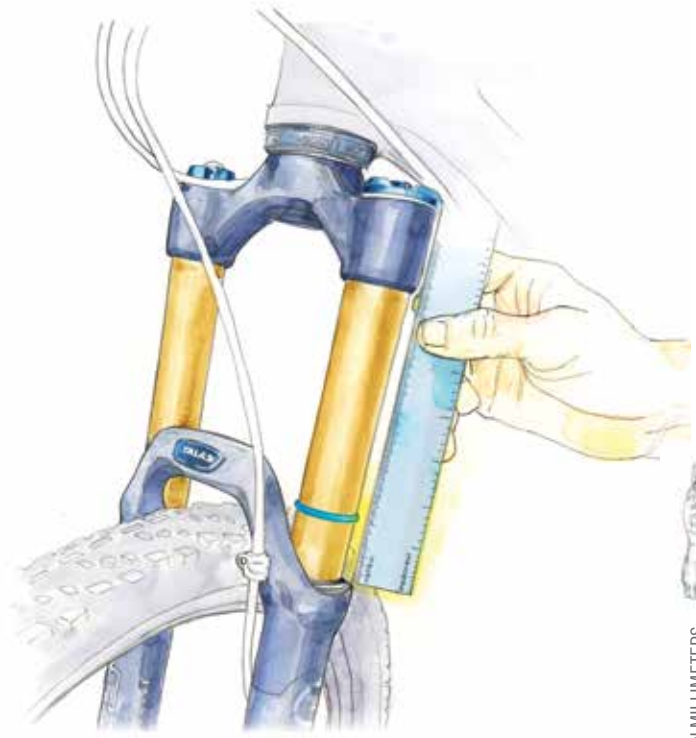
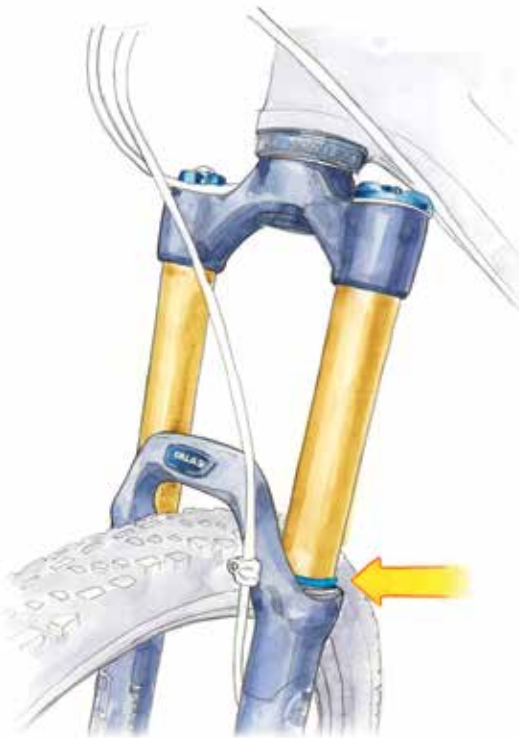

**STEP 2**

Slide o-ring until it rests on wiper, then dismount without disturbing o-ring's position.

**STEP 3**

Measure sag—the distance from o-ring to wiper. Start with sag of 15–20% of travel and adjust to your preference.

## FORK AIR PRESSURE CHARTS : STARTING PRESSURES FOR SETTING SAG



### FOX FLOAT 36 : 27.5 / 29\*

RIDER WEIGHT			160MM
LB	KG	PSI	
120-130	54-59	50	
130-140	59-64	54	
140-150	64-68	59	
150-160	68-73	62	
160-170	73-77	70	
170-180	77-82	71	
180-190	82-86	75	
190-200	86-91	80	
200-210	91-95	84	
210-220	95-100	88	
220-230	100-104	92	
230-240	104-109	97	
240-250	109-113	101	
MAX		120	

### FOX FLOAT 34 : 27.5 / 29\*

RIDER WEIGHT			140MM
LB	KG	PSI	
120-130	54-59	58	
130-140	59-64	63	
140-150	64-68	68	
150-160	68-73	72	
160-170	73-77	77	
170-180	77-82	82	
180-190	82-86	86	
190-200	86-91	91	
200-210	91-95	96	
210-220	95-100	100	
220-230	100-104	105	
230-240	104-109	110	
240-250	109-113	114	
MAX		120	

### FOX RHYTHM 34 : 29

RIDER WEIGHT			120MM
LB	KG	PSI	
120-130	54-59	58	
130-140	59-64	63	
140-150	64-68	68	
150-160	68-73	72	
160-170	73-77	77	
170-180	77-82	82	
180-190	82-86	86	
190-200	86-91	91	
200-210	91-95	96	
210-220	95-100	100	
220-230	100-104	105	
230-240	104-109	110	
240-250	109-113	114	
MAX		120	

### FOX STEPCAST 32: 29\*

RIDER WEIGHT			100MM
LB	KG	PSI	
120-130	54-59	65	
130-140	59-64	70	
140-150	64-68	74	
150-160	68-73	80	
160-170	73-77	85	
170-180	77-82	90	
180-190	82-86	96	
190-200	86-91	101	
200-210	91-95	106	
210-220	95-100	111	
220-230	100-104	117	
230-240	104-109	122	
240-250	109-113	126	
MAX		140	



DO NOT EXCEED  
MAXIMUM AIR PRESSURES

\*Air pressures above are for both  
Factory and Performance forks from Fox.



### DVO DIAMOND : 29

RIDER WEIGHT			160MM
LB	KG	PSI	
120-139	54-63	90-100	
140-159	64-72	100-110	
160-179	73-81	110-125	
180-199	82-90	125-130	
200-219	91-100	130-135	
220-239	100-108	135-140	
240+	109+	140-170	

For detailed base tune,  
see [page 46](#)





### **FORK SET-UP INFORMATION**

Read this first for a general understanding of fork set-up or skip straight to the air pressure charts (page 40) if you just want to go ride.

#### **POSITIVE PRESSURE**

This is the main air spring that supports your weight. Adjust the air pressure so that you come close to using all the travel on a typical ride. Usually you can mimic your maximum impacts by grabbing the front brake and pushing down **HARD** on the bars. If you are getting 80–90% of the fork's travel doing this, your positive air spring is in the right range. Actual riding will often push the fork a little further than this test.

#### **LOW SPEED COMPRESSION DAMPING**

Low speed compression damping is used to reduce unwanted movement and over travel due to low speed changes like out of the saddle pedaling and subtle variations in the trail that can cause wallowing etc. It also helps control frame geometry change during braking and cornering. Adjust to your preference.

---

### **IMPORTANT NOTE ABOUT FORKS ON ALL OUR BIKES**

For the best possible performance, be sure you are using the proper offset fork.

**DV9:** 51mm

**Ripley, Ripmo, Ripmo AF:** 44mm

**Mojo 3 and Mojo HD4:** 44mm

---

#### **LOCKOUT**

As the name implies this turns the fork rigid (or close to it) for out of the saddle efforts or riding on the road. Most forks have a “blowoff” so that the fork will move if a large enough impact is felt. The threshold or “blowoff” when the lockout lets the fork start to move is often adjustable. It's called Gate in Rock Shox parlance and Blowoff Threshold in Fox's language. Usually the goal is to have the lockout at the minimum setting needed to stop the fork movement while pedaling out of the saddle, but allowing it to still move fairly easily when an impact is felt.

#### **HIGH SPEED COMPRESSION DAMPING**

If your fork has a high speed compression damping control, this would usually be used to slow things down during big hits to avoid bottoming. It would usually be set at the lowest level needed to avoid bottoming out.

#### **REBOUND**

Adjust the rebound so that the front end does not bounce off the ground after a drop off or large bump. If adjusted too slow, the fork may “pack down” and feel sluggish. In order to conserve momentum and remain compliant the suspension needs to recover fairly quickly and push off the back side of bumps and holes. If the rebound is adjusted too slow, rolling energy is lost to damping and vibration. If it is adjusted too fast the bike will bounce after bumps and drops. Adjust to your preference.

## FORK SET-UP



## FOX 36 COMPRESSION DAMPING SETTINGS

**FOX 36 FACTORY SERIES  
GRIP2 COMPRESSION ADJUSTERS**

Use this diagram as a starting point for your compression adjusters.

Turn your compression adjusters to the closed position (full clockwise) until they stop. Then back them out (counter-clockwise) to the number of clicks shown below.



**High-Speed Compression**  
adjustment is useful to control fork performance during bigger hits, landings, and square-edged bumps.

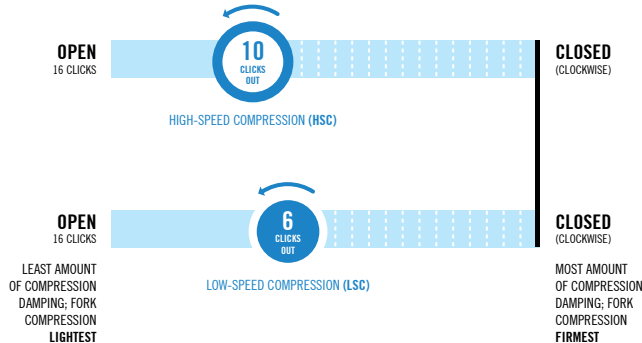

**Low-Speed Compression**  
adjustment is useful to control fork performance during rider weight shifts, G-outs, and other slow inputs.

**FOX 36 PERFORMANCE SERIES  
GRIP MICRO ADJUST**

The Performance Series 36 has a Grip damper with 3-position micro adjust. The lever has a full range of compression adjustment that increases as you turn the lever clockwise, combining low and high speed damping adjustment. As the lever is rotated clockwise from fully open, the damper adds low speed compression damping, then starts adding high speed compression damping and finally goes into lockout. You can access the full range on the fly. Start in the open position and adjust clockwise from there to counteract bob or increase damping control.

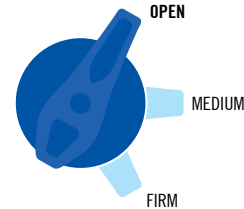

The **3-Position Micro Adjust** lever is useful to make on-the-fly adjustments to control fork performance. Use the positions between the **OPEN**, **MEDIUM**, and **FIRM** modes to fine-tune your compression damping.



**FOX 34 COMPRESSION DAMPING SETTINGS**

**FOX 34 FACTORY SERIES  
FIT4 COMPRESSION ADJUSTERS**

Use this diagram as a starting point for your compression adjusters.

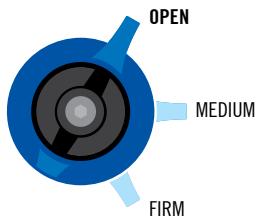

The **3-position lever** is useful to make on-the-fly adjustments to control fork performance under significant changes in terrain, and is intended to be adjusted throughout the ride.

Use the **OPEN** mode during rough descending, the **MEDIUM** mode for undulating terrain, and the **FIRM** mode for smooth climbing.

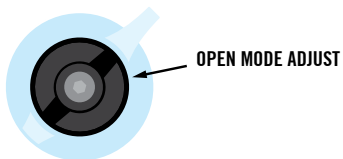

**OPEN mode adjust** is useful to control fork performance under rider weight shifts, G-outs, and slow inputs. **OPEN** mode adjust provides 22 additional fine tuning adjustments for the **OPEN** mode.

Setting 18 will have a more plush feel and setting 1 will have a firmer feel.



**FOX 34 PERFORMANCE SERIES  
GRIP MICRO ADJUST**

The Performance Series 34 has a Grip damper with 3-position micro adjust. The lever has a full range of compression adjustment that increases as you turn the lever clockwise, combining low and high speed damping adjustment. As the lever is rotated clockwise from fully open, the damper adds low speed compression damping, then starts adding high speed compression damping and finally goes into lockout. You can access the full range on the fly. Start in the open position and adjust clockwise from there to counteract bob or increase damping control.

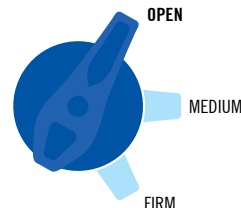

The **3-Position Micro Adjust** lever is useful to make on-the-fly adjustments to control fork performance. Use the positions between the **OPEN**, **MEDIUM**, and **FIRM** modes to fine-tune your compression damping.

The **2-Position Sweep Adjust** (34 Rhythm forks on DV9 only) lever is useful to make on-the-fly adjustments to control fork performance. Use the positions between **OPEN** and **FIRM** modes to fine-tune your compression damping.

## FORK SET-UP

### FOX 36 REBOUND

The rebound adjustment is dependent on the air pressure setting. For example, higher air pressures require lower rebound settings. Use your air pressure to find your rebound setting.

Turn your rebound knob to the closed position, clockwise until it stops. Then turn it counter-clockwise to the number of clicks shown in the table to your right.

### FORKS

We offer both Fox Factory and Performance forks for our various parts packages.

The Performance series fork share much of the Factory fork's DNA. You can distinguish a Performance by the black anodized stanchions, rather than the Kashima coat. The Performance series forks utilize Fox's GRIP damping system, a single lever (shown below) that adjusts both low and high speed compression through a wide range from open to firm.

#### FOX PERFORMANCE GRIP ADJUSTER

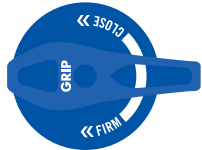

### REBOUND SETTINGS FOX 36 : 27.5 / 29

RIDER WEIGHT (LBS)	RECOMMEND REBOUND SETTINGS GRIP	RECOMMEND REBOUND SETTINGS GRIP 2	
		LSR	HSR
120-130	13	9	8
130-140	12	8	7
140-150	11	7	6
150-160	10	7	6
160-170	9	6	5
170-180	8	6	5
180-190	7	5	4
190-200	6	4	3
200-210	5	4	3
210-220	4	3	2
220-230	3	2	1
230-240	2	2	1
240-250	1	1	0

#### FOX 36 REBOUND ADJUSTERS

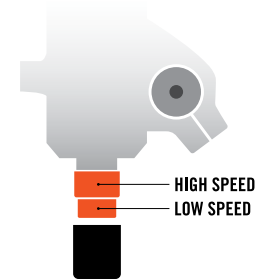

Rebound controls the rate of speed at which the fork extends after compressing.

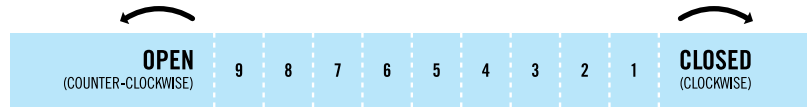

LEAST AMOUNT OF REBOUND DAMPING, FORK REBOUNDS FASTEST

MOST AMOUNT OF REBOUND DAMPING, FORK REBOUNDS SLOWEST





**REBOUND SETTINGS  
FOX 34 : 27.5 / 29**

RIDER WEIGHT (LBS)	RECOMMEND REBOUND SETTINGS FIT4	RECOMMEND REBOUND SETTINGS GRIP
120-130	14	13
130-140	13	12
140-150	12	11
150-160	11	10
160-170	9	9
170-180	8	8
180-190	7	7
190-200	6	6
200-210	5	5
210-220	4	4
220-230	3	3
230-240	2	2
240-250	1	1

**REBOUND SETTINGS  
FOX 32 : 29**

RIDER WEIGHT (LBS)	RECOMMEND REBOUND SETTINGS FIT4
120-130	14
130-140	13
140-150	12
150-160	11
160-170	9
170-180	8
180-190	7
190-200	6
200-210	5
210-220	4
220-230	3
230-240	2
240-250	1

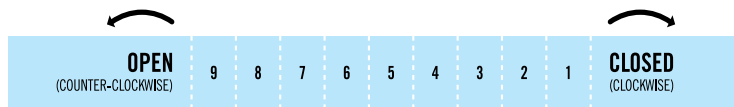

LEAST AMOUNT OF REBOUND DAMPING, FORK REBOUNDS FASTEST

MOST AMOUNT OF REBOUND DAMPING, FORK REBOUNDS SLOWEST

**FOX 34 / 32 REBOUND ADJUSTERS**



Rebound controls the rate of speed at which the fork extends after compressing.

**A NOTE ON TUNING GUIDES**

Tuning Guides for current and legacy Fox forks and shocks can be found at [ridefox.com](http://ridefox.com). While our info here is thorough, Fox has even more detail on their support pages. We recommend you check it out.

As an FYI, here's the GRIP info: <http://www.ridefox.com/help.php?m=bike&id=690#adjustinggripcompressiondamping>

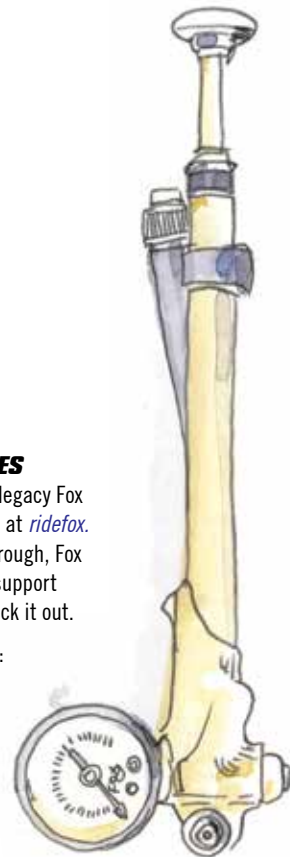

**FORK SET-UP****DVO DIAMOND**

The DVO Diamon features adjustable high and low speed compression damping, adjustable rebound damping, and Off the Top (OTT), which adjusts the initial sensitivity of the travel.

For even more detailed tuning instructions, go to <http://tech.dvosuspension.com/setup/diamond/>

**DVO DIAMOND : 29**

RIDER WEIGHT		160MM				
LB	KG	PSI	OTT	REBOUND	HSC	LSC
120-139	54-63	90-100	0-2 rotations	10-14 clicks	0-1 clicks	1-2 clicks
140-159	64-72	100-110	2-4 rotations	10-14 clicks	0-2 clicks	1-2 clicks
160-179	73-81	110-125	3-7 rotations	8-12 clicks	2-3 clicks	1-2 clicks
180-199	82-90	125-130	6-8 rotations	8-12 clicks	2-4 clicks	1-2 clicks
200-219	91-100	130-135	7-9 rotations	6-10 clicks	3-5 clicks	1-2 clicks
220-239	100-108	135-140	8-10 rotations	6-10 clicks	6-10 clicks	1-2 clicks
240+	109+	140-170	8-10 rotations	6-10 clicks	6-10 clicks	1-2 clicks

**Air Pressure Range:** 90-170psi

**OTT Range:** 6 clicks = 1 full rotation. 14 full rotations total.

**Rebound Range:** 20 clicks total

**High Speed Compression (HSC) Range:** 29 clicks total

**Low Speed Compression (LSC) Range:** 6 clicks total

Compression is adjusted at the top of the right fork leg, rebound at the bottom. Air pressure is adjusted at the top of the left fork leg and OTT at the bottom.

When setting up your compression and OTT, start from Wide-Open (turn the adjuster counter-clockwise until it stops). The Compression and OTT adjustments above refer to making adjustments clockwise from the Wide-Open setting.

When setting up your rebound, start from fully closed (knob turned all the way clockwise). The rebound adjustment above refers to making adjustments counter-clockwise from the Fully-Closed setting.



↑ IBIS ↑

MIGRATION

**REAR SHOCK SET-UP****SETTING SAG**

Recommended beginning pressures can be found on [page 50-51](#). Set the pressure and follow the instructions on this page for setting the sag.

Less pressure gives a slacker seat angle and overall smoother ride. More pressure gives a firmer suspension feel and steeper seat angle and more over the pedals riding position.

**Ripmo / Ripmo AF / Mojo HD4**

Shoot for .55" (~14mm) of sag.

**Ripley**

Shoot for .45" (~11mm) of sag.

**Mojo 3**

Shoot for .47" (~12mm) of sag.

**CHECK THE SAG**

With the shock in open mode (or ProPedal turned off for earlier shocks), sit on your bike in a normal riding position. Reach down and slide the o-ring up the shock shaft against the wiper seal. Next, gently step off of the bike taking care not to further compress the suspension.

For the Ripley, the distance from the o-ring to the wiper seal should be about 11mm.

On the Mojo HD4 and Ripmo, sag should be about 14mm for Trail and 15–17mm for gravity rides. Experiment and see what works best for your trails and riding style.

**FOX FLOAT DPS**

The Float DPS has totally new internals over prior Float shocks, and is a huge improvement. There is a wider range of compression adjustment when you change positions using the blue lever. The shock has the negative air chamber that gives both better small bump compliance AND more support though the mid stroke. It also gives increased bottoming resistance.

There's a 3 position on-the-fly (lever) adjustment like before. They control low speed compression damping. They're called **Open-Medium-Firm**. The **Open** mode is the tunable one. That enables you to adjust the mode that you use most often, then have the preset **Medium** and **Firm** modes if you want to firm things up for fire road climbing or pavement (we rarely use these settings on our bikes).

**ADJUSTING REBOUND**

The Float DPS has adjustable rebound damping. It's adjusted by turning the red dial on the inside of the lever. Generally you want it as fast as you can set it without getting bounced off the saddle after a bump or drop (like riding off a curb in the saddle.) If the rebound setting is too slow the shock will be partially compressed when you hit the next bump resulting in "packing down". Too fast and the bike will bounce you up in the air after bumps and drops. Adjust to your preference.

Our suspension bikes have the following shock and shock hardware specifications:

**Ripley Shock**

- Upper: 25mm wide with an 8mm bore
- Lower: 15mm wide with an 8mm bore
- 190mm eye to eye
- 45mm shaft travel

**Ripmo/Ripmo AF Shock**

- Upper: 25mm wide with an 8mm bore
- Lower: 15mm wide with an 8mm bore
- 210mm eye to eye
- 55mm shaft travel

**Mojo HD4 Shock:**

- Upper: 21.8mm wide with an 8mm bore
- Lower: 15mm wide with an 8mm bore
- 7.875" (200mm) eye to eye
- 2.25" (57mm) shaft travel

**Mojo 3 Shock:**

- Upper: 21.8mm wide with an 8mm bore
- Lower: Bushing removed, 15mm bore
- 7.875" (200mm) eye to eye
- 2" (51mm) shaft travel

**SETTING AIR PRESSURE FOR THE FIRST TIME WITH THE NEGATIVE AIR CHAMBER SLEEVE**

It is critically important to add or remove air from the negative air chamber sleeve as detailed below to experience the best possible performance.

**IMPORTANT NOTE:** When adding air to the air chamber, it is crucial to equalize the positive and

negative air chambers by slowly compressing the shock through 25% of its travel 10-20 times after every 50psi addition.

Adding air to the shock without periodically equalizing the air chambers can lead to a condition in which the shock has more pressure in the positive chamber than the negative. In this condition the shock will be very stiff and can top-out. You can equalize the air chambers by slowly compressing the shock until you feel and hear a transfer of air. Hold the shock at this point for a few seconds to allow the air to transfer from the positive to the negative chamber.

When releasing air from the air chamber, it is important to do this slowly so the shock can transfer air from the negative to positive chamber and then be released through the Schrader valve.

Releasing the air pressure too quickly can induce a condition in which the negative chamber has more pressure than the positive chamber. In this condition the shock will compress into its travel and not fully extend. You can remedy this by adding air pressure until the shock extends, then slowly compressing the shock through 25% of its travel 10-20 times.



## AFTERMARKET SUSPENSION

We work closely with the engineers at Fox to custom tune the shocks on each of our bikes. If you are looking to update your Ibis to the latest 2020 Fox suspension, here is all the information you will need, part numbers, descriptions and what you will need to have a Fox trained technician change on your new shock.

Fork aftermarket part numbers for 2020 are included too. Unless noted we use stock tunes on all the forks so no modification is needed.



### AFTERMARKET FORKS

BIKE MODEL	FOX AM P/N	DESCRIPTION
DV9 (100mm w/remote lockout)	910-20-733	2020, 32, K, FLOAT SC, 29in, F-S, 100, FIT4, Remote-Adj, Psh-Unlik, 2Pos, (10pm CP), Matte Blk, Orange/Matte Blk Logo, Kabolt 110, BLK, 1.5 T, 51mm Rake, AM
DV9 (120mm non-remote)	910-20-728	2020, 34, K, FLOAT SC, 29in, F-S, 120, FIT4, 3Pos-Adj, Matte Blk, Orange/Matte Blk Logo, Kabolt 110, BLK, 1.5 T, 51mm Rake, AM
Mojo 3	910-20-783	2020, 34, K, FLOAT, 27.5in, F-S, 140, FIT4, 3Pos-Adj, Matte Blk, Orange/Matte Blk Logo, 15QRx110, 1.5 T, 44mm Rake, AM
Mojo HD4	910-20-767	2020, 36, K, FLOAT, 27.5in, F-S, 160, Grip 2, HSC, LSC, HSR, LSR, Matte Blk, Orange/Matte Blk Logo, 15QRx110, 1.5 T, 44mm Rake, AM
Ripley 4	910-20-717	2020, 34, K, FLOAT, 29in, F-S, 130, FIT4, 3Pos-Adj, Matte Blk, Orange/Matte Blk Logo, 15QRx110, 1.5 T, 44mm Rake, AM
Ripmo*	910-20-696	2020, 36, K, FLOAT, 29in, F-S, 160, Grip 2, HSC, LSC, HSR, LSR, Matte Blk, Orange/Matte Blk Logo, 15QRx110, 1.5 T, 44mm Rake, AM

\*To match the OEM tune of the Ripmo Factory fork, Revalve damper to light rebound (RL)

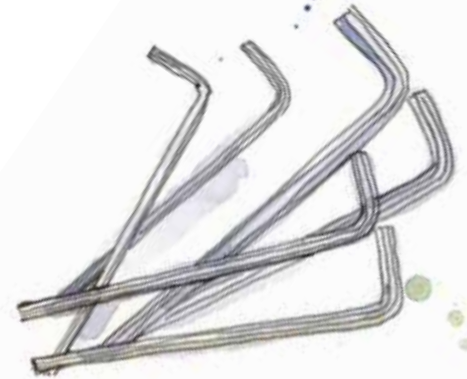



## AFTERMARKET SHOCKS

BIKE MODEL	FOX AM P/N	DESCRIPTION	NOTES FOR CONVERTING AFTERMARKET DAMPER TO IBIS OEM SPECIFICATION
Mojo 3 Float DPS	972-01-411	2020, FLOAT DPS, F-S, K, 3pos-Adj, Evol LV, FOX, AM, 7.875, 2.0, 0.6 Spacer, LCM, LRM, CMF, Orange Logo	Revalve damper to DCL, DRM, CMF. Install 0.8 cu in air volume reducer.
Mojo 3 Float DPS (Roxy Tune)	972-01-411	2020, FLOAT DPS, F-S, K, 3pos-Adj, Evol LV, FOX, AM, 7.875, 2.0, 0.6 Spacer, LCM, LRM, CMF, Orange Logo	Revalve damper to DCXL, DRL, CMF. Install 0.8 cu in air volume reducer.
Mojo HD4 Float X2	973-01-243	2020, FLOAT X2, F-S, K, 2pos-Adj, FOX, AM, 7.875, 2.25, 0.3 Spacer x2, CM, Orange, Gray Logo	Revalve damper to CL. Remove all air volume reducers.
Mojo HD4 Float DPX2	973-01-235	2020, FLOAT DPX2, F-S, K, 3pos-Adj, Evol LV, FOX, AM, 7.875, 2.25, 0.2 Spacer, CM, DRM, Rezi A F F, Orange Logo	Remove air volume reducer.
Ripley 4 Float DPS	972-01-432	2020, FLOAT DPS, F-S, K, 3pos-Adj, Evol LV, FOX, AM, 190, 45, 0.4 Spacer, LCM, LRM, CMF, Orange Logo	Revalve damper to LCL, LRM, CMF. Install 0.6 cu in air volume reducer.
Ripmo Float X2	973-01-267	2020, FLOAT X2, F-S, K, 2pos-Adj, FOX, AM, 210, 55, 0.3 Spacer x3, CM, Orange, Gray Logo	Revalve damper to CM, RL. Remove 2 air volume reducers from stock shock (leaving only 1 inside).
Ripmo Float DPX2	973-01-256	2020, FLOAT DPX2, F-S, K, 3pos-Adj, Evol LV, FOX, AM, 210, 55, 0.2 Spacer, CM, DRM, Rezi A F M+, Orange Logo	Revalve damper to DCXL, DRXL, AFM. Install 0.4 cu in air volume reducer. "Rezi A F M" indicates the open mode compression damping is adjustable by 3mm hex wrench instead of the fixed "L" light open mode of the stock Performance Series damper.

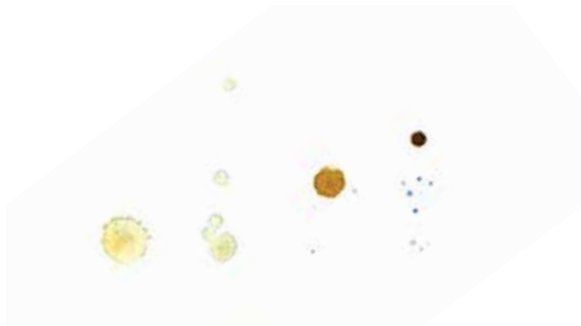

**REAR SHOCK AIR PRESSURE CHARTS : STARTING PRESSURES FOR SETTING SAG****REAR SHOCKS****FOX X2 : RIPMO**

25% SAG - Shoot for .55" (~14mm) of sag.

RIDER WEIGHT	PRESSURE
LB	PSI
125	145
140	165
165	190
180	210
200	240
220	265

**MAX 300 PSI!****FOX DPS : RIPLEY**

25% SAG - Shoot for .45" (~11mm) of sag.

RIDER WEIGHT	PRESSURE
LB	PSI
100	130
120	150
140	170
160	190
180	210
200	240
220	270
250	310

**MAX 350 PSI!****FOX DPX2 : RIPMO**

25% SAG - Shoot for .55" (~14mm) of sag.

RIDER WEIGHT	PRESSURE
LB	PSI
125	145
140	165
165	190
180	210
200	240
220	265

**MAX 350 PSI!****FOX DPS : MOJO 3**

25% SAG - Shoot for .47" (~12mm) of sag.

RIDER WEIGHT	PRESSURE
LB	PSI
100	120
120	140
140	160
160	200
180	200
200	230
220	260
250	300

**MAX 350 PSI!**

**Note:** For riders under 120lbs on the Mojo 3, we offer the Roxy Tune shock (but it is not required!).

**IMPORTANT NOTE ABOUT SUSPENSION SETTINGS ON ALL OUR BIKES**

These are Ibis recommended settings and differ from FOX recommended settings.

**DVO JADE X**

DVO worked with our National Enduro Team and our engineers to come up with a damping profile to match the new Ripmo AF kinematics.



The Jade X features a 3 position compression adjuster that allows the rider to choose from full open (descending) mid position (single track or climbing) to near lock out for the 3rd position.

They also came up with a new rebound damping profile that has built in low speed rebound during the initial part of the suspension movement, keeping the bike feeling composed and balanced. The middle part of the rebound stroke (the sweet spot) allows for rapid movement which keeps the rear wheel tracking the ground without packing down and the end of stroke slows down again reducing the possibility of getting bucked during jumps or larger impacts.

**REAR SHOCKS****DVO JADE X : RIPMO AF****COIL SPRING WEIGHT GUIDE**

RIDER WEIGHT LB	SPRING WEIGHT LB
140-155	350
155-170	400
170-185	450
185-200	500
200-215	550
215-330	600

**NOTE: Ripmo AF ships with the following standard coil springs**

Small:	350
Medium:	400
Large:	450
X-large:	500

**DVO TOPAZ : RIPMO AF****27.5% SAG / 14MM**

RIDER WEIGHT LB	PRESSURE PSI
120-130	112-123
130-140	123-134
140-150	134-144
150-160	144-155
160-170	155-166
170-180	166-177
180-190	177-187
190-200	187-198
200-210	198-209
210-220	209-220
220-230	220-230
230-240	230-241
240-250	241-252

The Topaz has a three position compression damping switch. As with all of our dw-link bikes, we prefer to run them WFO (wide open) and let the dw-link do it's magic.

For rebound, adjust to personal preference, as outlined on [page 48](#).

**REAR SHOCK AIR PRESSURE CHARTS : STARTING PRESSURES FOR SETTING SAG**

**BALANCING YOUR SUSPENSION**

It's best to balance your suspension for different types of riding.

- If your normal descent is **10-15%** down grade, use recommended pressures.
- If your normal descent is **20-25%** down grade, reduce **rear shock** pressure by **4%** and increase **fork** pressure by **4%** over recommended pressure.
- If your normal descent is **30+%** down grade, reduce **rear shock** pressure by **8%** and increase **fork** pressure by **4%** over recommended pressure.

		<b>X2 : HD4</b>			<b>DPX2 : HD4</b>		
HD4 SAG	28%	30%	32%	28%	30%	32%	
RIDER WEIGHT (LBS.)	SHOCK PRESSURE (PSI)	SHOCK PRESSURE (PSI)	SHOCK PRESSURE (PSI)	SHOCK PRESSURE (PSI)	SHOCK PRESSURE (PSI)	SHOCK PRESSURE (PSI)	
120 - 130	124	119	113	131	126	118	
130 - 140	134	129	123	143	137	130	
140 - 150	144	138	133	155	149	142	
150 - 160	153	148	142	166	161	153	
160 - 170	163	158	152	178	172	165	
170 - 180	173	168	162	190	184	177	
180 - 190	183	178	172	202	196	189	
190 - 200	193	187	182	214	207	201	
200 - 210	203	197	191	226	219	213	
210 - 220	213	207	201	238	231	225	
220 - 230	223	217	211	250	242	237	
230 - 240	233	226	221	262	254	249	
240 - 250	243	236	231	273	266	260	

**FLOAT X2 DAMPER ADJUSTMENTS**

Turn all four damper adjusters to the closed position (full clockwise) until they stop. Then back them out (counter-clockwise) to the number of clicks shown in the table.

**IMPORTANT NOTE:** Be careful not to force the low speed adjusters to the end of their range. Rotating Low Speed Compression (LSC) or Low Speed Rebound (LSR) adjusters to min or max too forcefully can cause them to get stuck. If they do get stuck, use FOX tool 398-00-746 to hold the high speed adjuster in place while loosening the low speed adjuster.

**FOX FLOAT X2 BASE SETTINGS**

*Count Clicks from Closed: 0 Clicks = Closed\**



Rebound



Compression

AIR SPRING PRESSURE	RECOMMENDED LSR SETTING	RECOMMENDED HSR SETTING	RECOMMENDED LSC SETTING	RECOMMENDED HSC SETTING
90	22-OPEN	22-OPEN	20-22	21-23
100	22-24	22-24	19-21	19-21
110	19-21	19-21	18-20	18-20
120	18-20	18-20	18-20	17-19
130	18-20	18-20	17-19	16-18
140	17-19	17-19	17-19	16-18
150	16-18	16-18	16-18	15-17
160	16-18	16-18	16-18	15-17
170	15-17	15-17	15-17	14-16
180	15-17	15-17	14-16	13-15
190	14-16	14-16	14-16	13-15
200	13-15	13-15	13-15	12-14
210	12-14	12-14	12-14	11-13
220	11-13	11-13	12-14	11-13
230	10-12	10-12	11-13	10-12
240	9-11	9-11	10-12	10-12
250	8-10	8-10	10-12	9-11

**FLOAT DPX2 REBOUND ADJUSTMENT**

The rebound adjustment is dependent on the air pressure setting. For example, higher air pressures require slower rebound settings. Use your air pressure to find your rebound setting.

Turn the rebound knob to the closed position (full clockwise) until it stops. Then back it out (counter-clockwise) to the number of clicks shown in the table below.

**FOX DP X2 REBOUND SETTINGS**

AIR SPRING PRESSURE	STARTING REBOUND SETTING
<120	Open (counter-clockwise)
120-140	13
140-160	12
160-180	11
180-200	10
200-220	8
220-240	7
240-260	5
260-280	3
280-300	2

## BEARING / BUSHING MAINTENANCE AND REPLACEMENT

### WORKING ON MOJO HD4/MOJO 3

The linkage assemblies on the Mojo HD4 and Mojo 3 are designed to be removed and replaced easily. Be sure to purchase a fresh link set before removing the old ones to skip any downtime. There are no bearings to press out, nor any axles to hammer. Upper and lower pivot assemblies are available in the buy section of our website, or you can have your dealer order them from Ibis for you. Replacement is super simple and requires these common tools:

- 2x 4mm Allen wrenches
- 2x 5mm Allen wrenches
- 2x 6mm Allen wrenches
- Loctite 243 (or 242) blue thread locker

### REPLACING LINKAGES

Please refer to the section on Mojo HD4 and Mojo 3 Swingarm Removal in this manual on [pages 64-69](#).

### BEARING REPLACEMENT

If you're handy with a bench vice and have a good supply of sockets, you can attempt the replacement of the bearings in the upper and lower link yourself. While we don't have step-by-step instructions, you are welcome to purchase the bearings and try it yourself.

**Note:** *The only way we ever see links damaged is by people trying to replace their bearings. Experts only.*

### MOJO HD4/MOJO 3 BEARING SPECS

The lower links use DDR1526 bearings on the drive side and 6902rs on the non-drive side. The upper links are 6800rs all around.

### BEARING KITS

Enduro Bearing kits are available for all modern Ibis suspension bikes at <http://www.enduroforkseals.com/id245.html>



**BUSHING SERVICE INTERVALS**

Clevis bushings should be checked, cleaned, and serviced after every wet season. If the majority of riding is in wet weather, the bushing service interval should be performed more often.

In general bushings and o-rings should be replaced once a year. For primarily wet conditions bushings may need to be replaced more often. In primarily dry conditions, replacement bushings may be needed less often.



FRAME HARDWARE : RIPMO

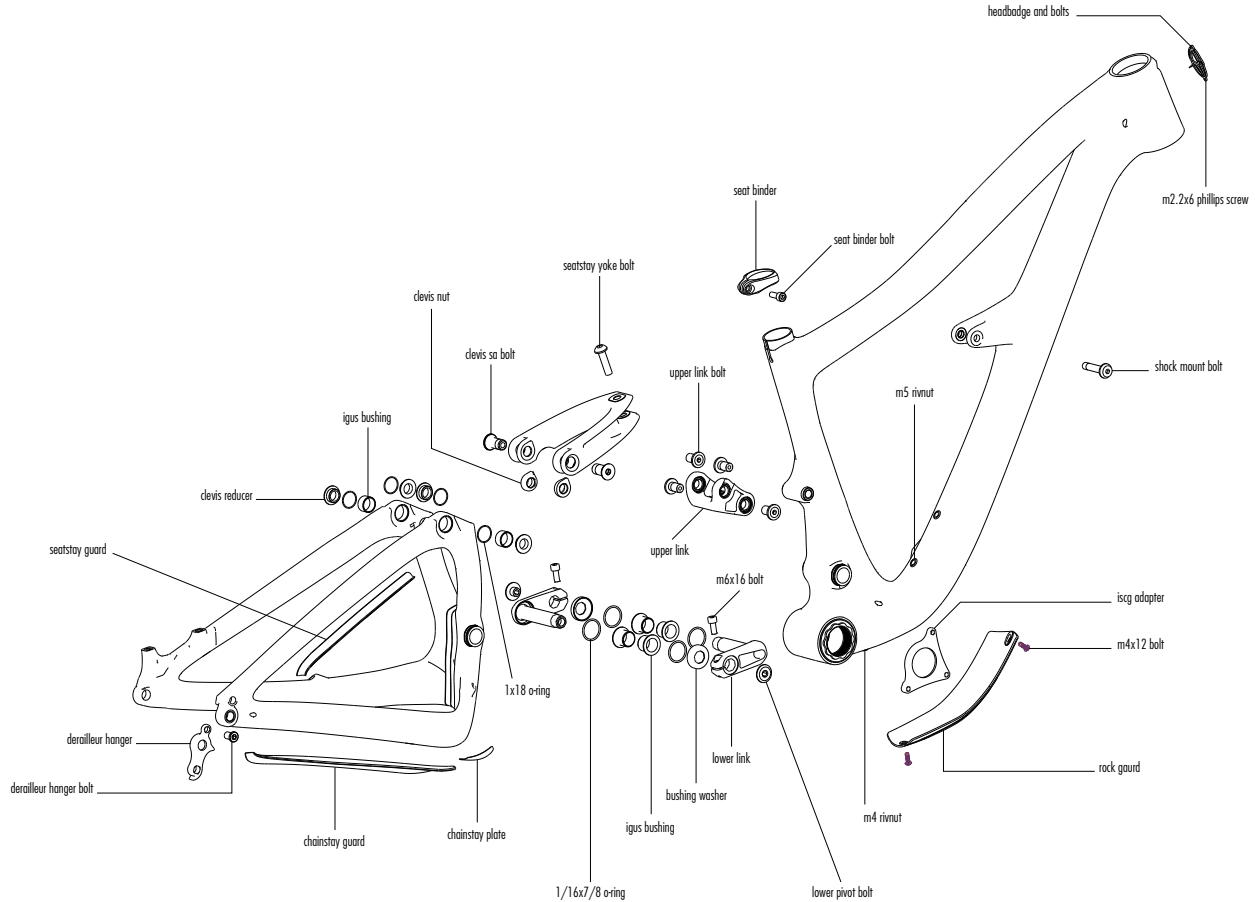

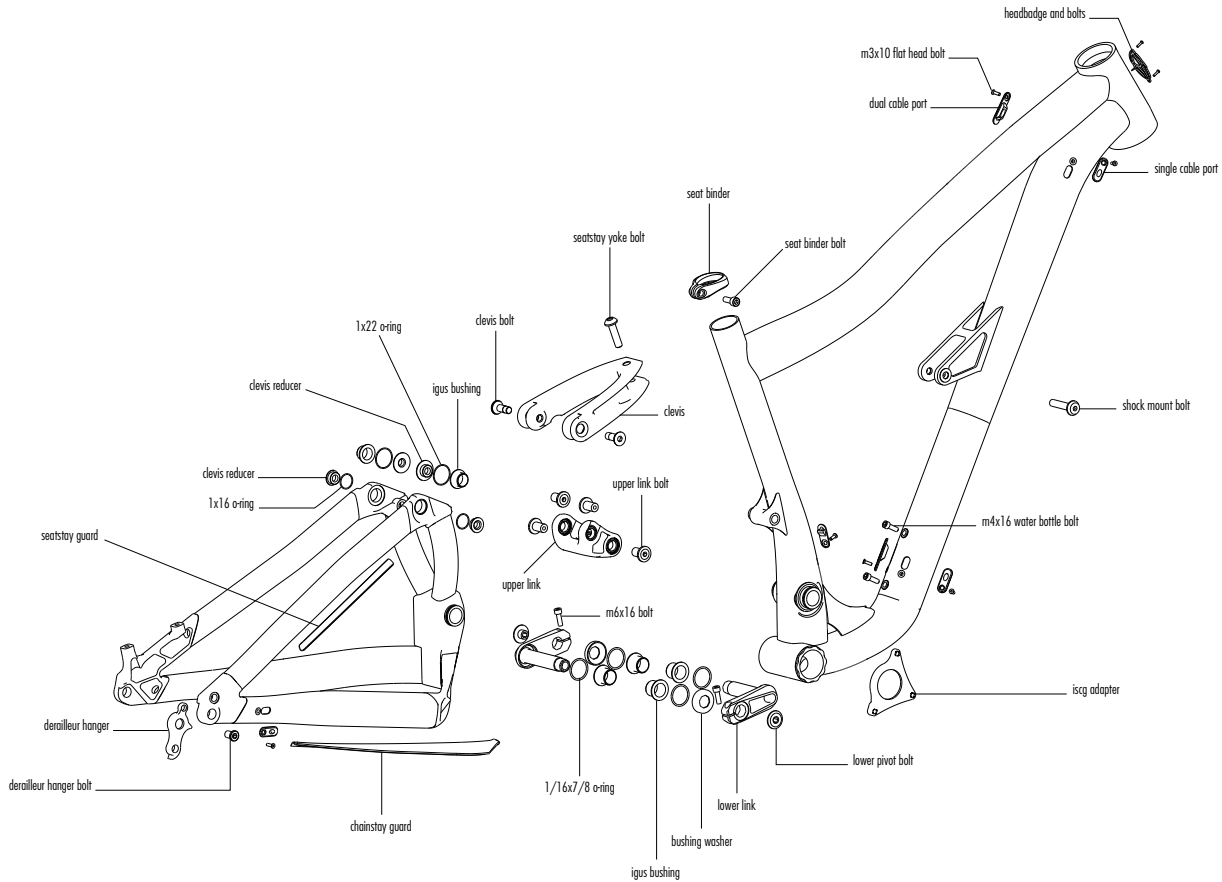

FRAME HARDWARE : RIPLEY

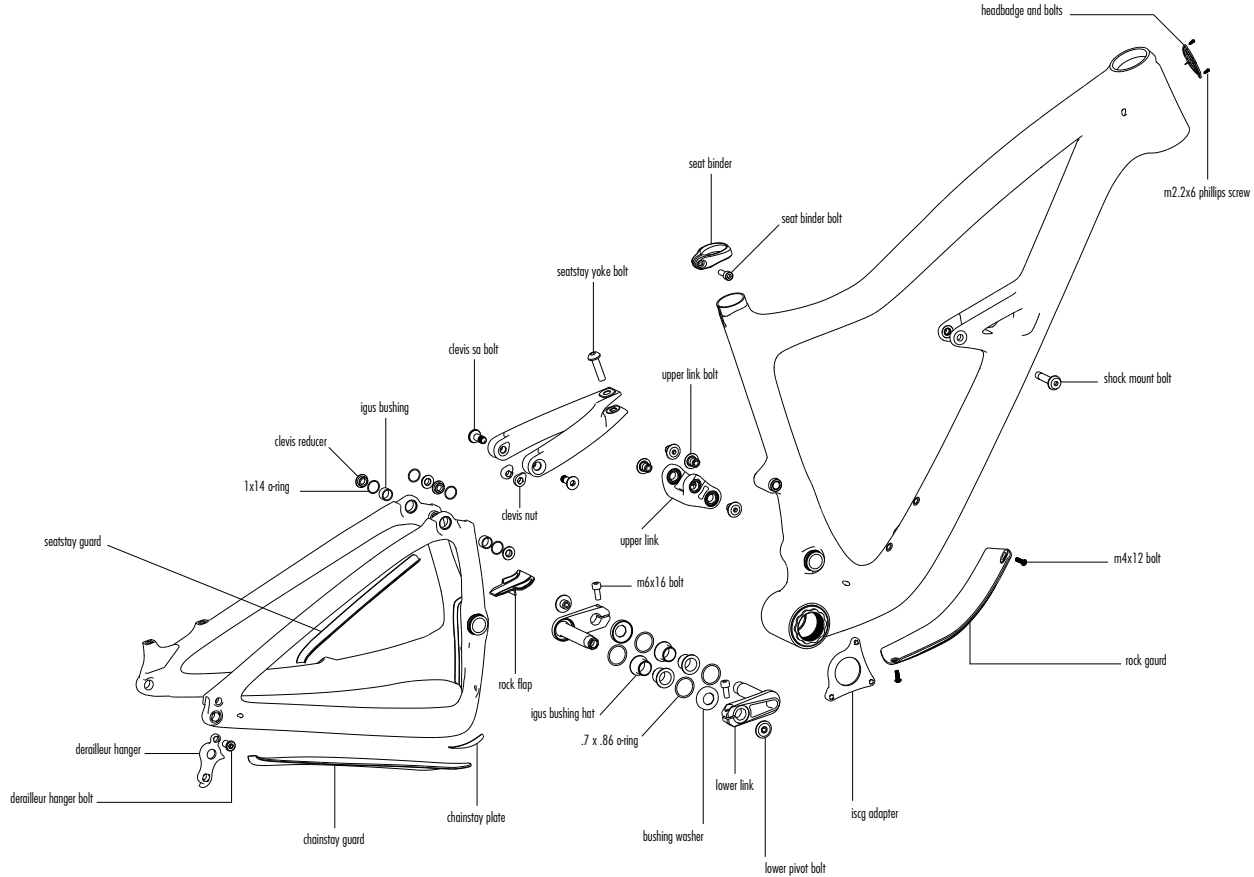

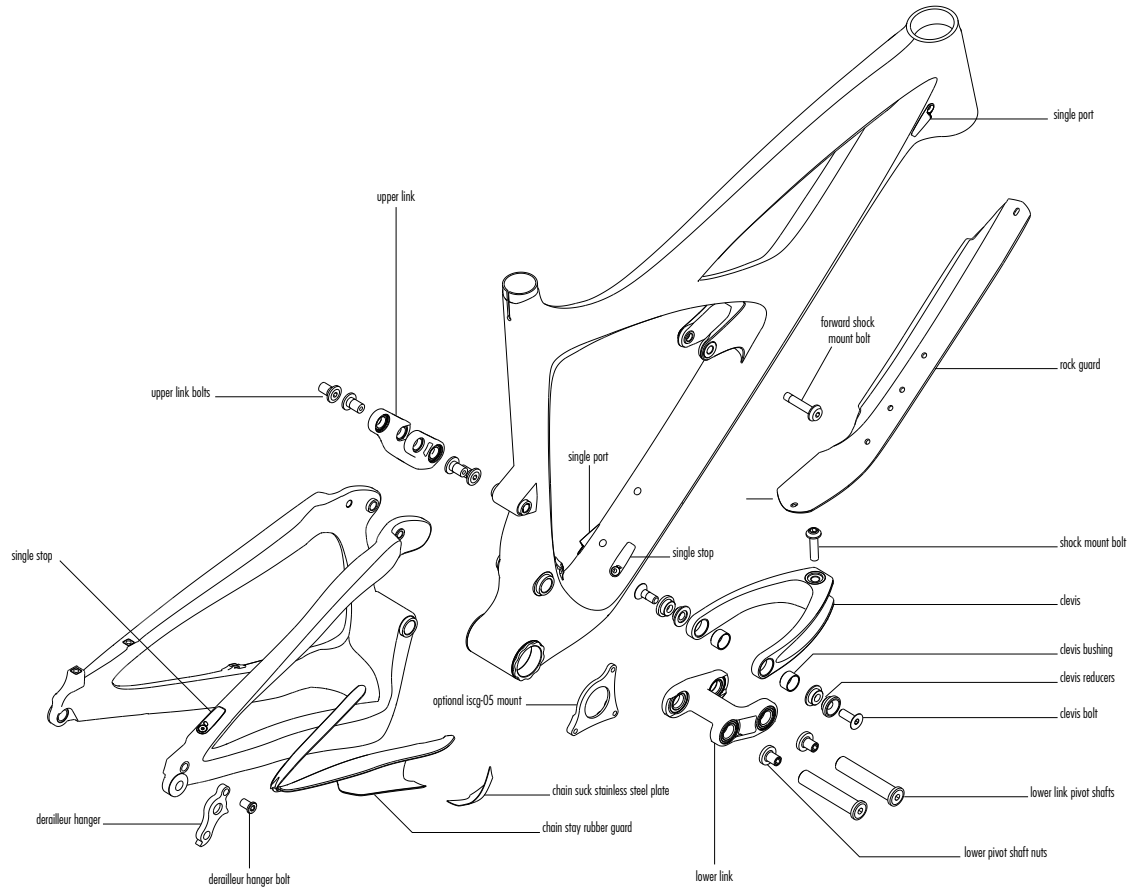

FRAME HARDWARE : MOJO 3

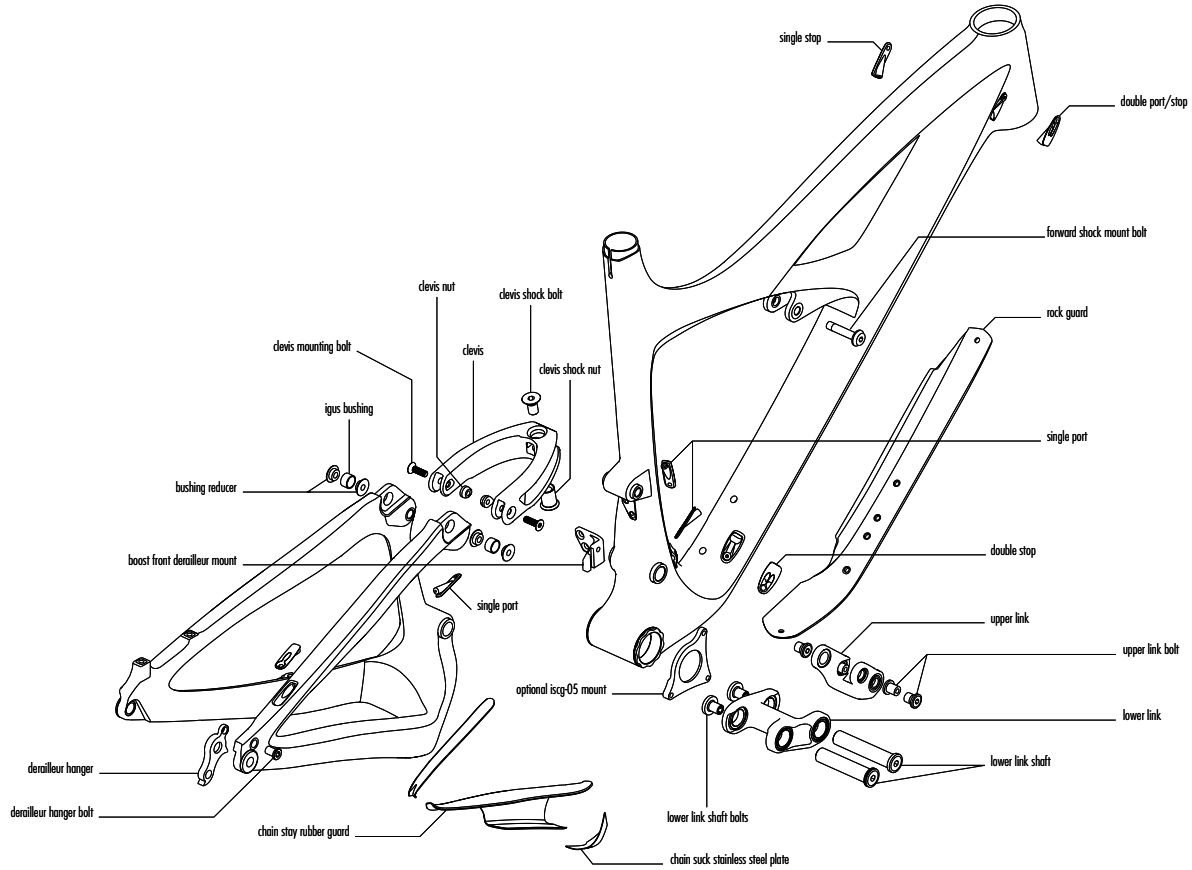



## TORQUE SPECS

### MOJO 3

**Note on 243 Loctite:** Shake the bottle well before applying!

HARDWARE	TORQUE SPEC.	THREAD TREATMENT
Cable Port	2 Nm	Grease
Clevis to Swingarm Bolts	8 Nm	Loctite 243
Lower Links	24 Nm	Loctite 243
Lower Shock to Clevis Bolts	24 Nm	Loctite 243 on the threads, grease on the outer diameter of the nut
Rear Brake Caliper	6 Nm	Loctite 243
Upper Link Bolts	10 Nm	Loctite 243
Upper Shock Mount Bolts	10 Nm	Loctite 243 on threads, grease under head of bolt or mylar washer
Seat Binder	5 Nm	Ti anti-seize
Derailleur Hanger Bolt	5 Nm	Grease

### MOJO HD4

HARDWARE	TORQUE SPEC.	THREAD TREATMENT
Cable Port	2 Nm	Grease
Clevis to Swingarm Bolts	15 Nm	Titanium Bolts: Loctite 243 on threads, Ti anti-seize under head of bolt
Lower Links	24 Nm	Loctite 243
Lower Shock to Clevis Bolts	20 Nm	Titanium Bolts: Loctite 243 on threads, Ti anti-seize under head of bolt
Rear Brake Caliper	6 Nm	Loctite 243
Upper Link Bolts	10 Nm	Loctite 243
Upper Shock Mount Bolts	10 Nm	Loctite 243 on threads, grease under head of bolt or mylar washer
Seat Binder	5 Nm	Ti anti-seize
Derailleur Hanger Bolt	5 Nm	Grease

### BUSHINGS

On all models, apply Slick Honey (grease) to all bushings during reassembly.

### HEXLE REAR AXLE

There is not a numerical torque figure for the Hexle. We recommend tightening the 5mm with your multi tool that you carry with you. This way you'll be able to remove it in case of a flat out on a ride.





**SWINGARM REMOVAL : RIPMO / RIPMO AF / RIPLEY**

**DISASSEMBLY/REASSEMBLY**

Put your freshly cleaned Ripmo / Ripmo AF / Ripley in a work stand, remove cranks, and the rear wheel. Follow steps 1-6 for disassembly, and in reverse order for reassembly.

**NOTE:** Assembly and disassembly are the same but the clevis pivot for the Ripmo AF uses a different bushing.

**STEP 1**

Remove the shock and clevis assembly by removing the upper shock mount bolt with a 5mm Allen wrench\*. Next, remove the clevis to swingarm bolts with a 5mm Allen.

*\*On the upper shock mount, be careful not to lose the thin black washers that go on the outside of the shock eyelet.*

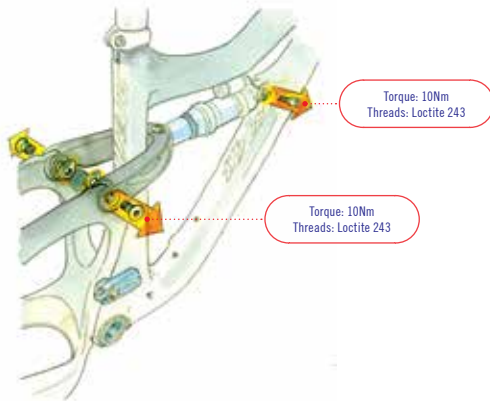

**STEP 2**

Carefully separate the shock and clevis assembly from the frame.

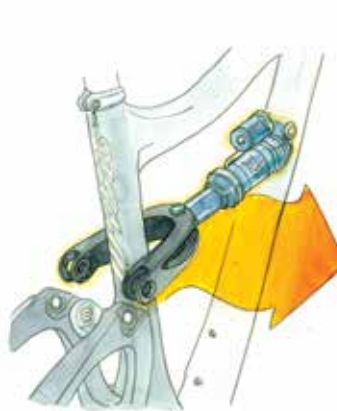

**STEP 3**

Remove the lower shock mount bolt with a 6mm Allen.

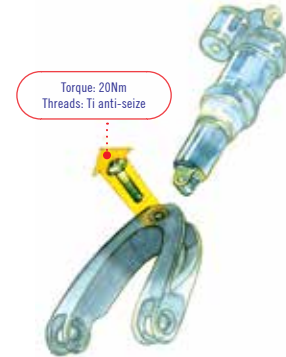

**PRO TIP:** During reassembly, note the torque specs and thread treatments



We have two video tutorials on both removal and replacement of the Ripmos / Ripleys lower link bushing on our website: [https://www.ibiscycles.com/support/support\\_videos](https://www.ibiscycles.com/support/support_videos)

**STEP 4**

Remove 4 upper link bolts.

**STEP 5**

Remove upper link from swingarm and front triangle.

**STEP 6**

Loosen pinch bolts, remove preload bolts. Link is two pieces, to remove pull two sides of link apart while supporting the swingarm.

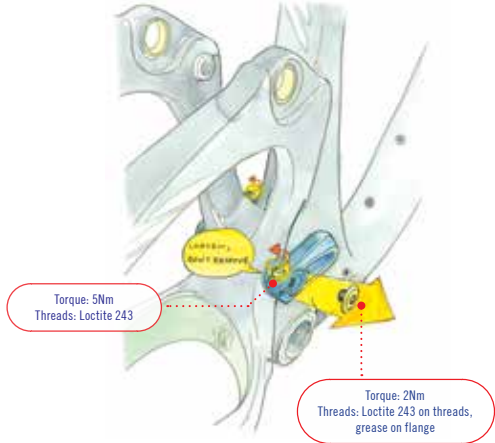
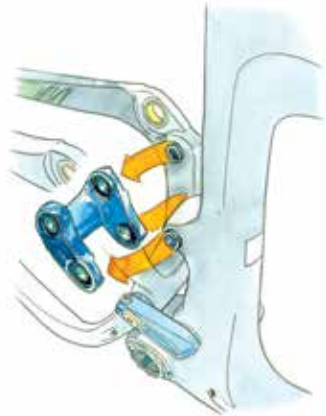
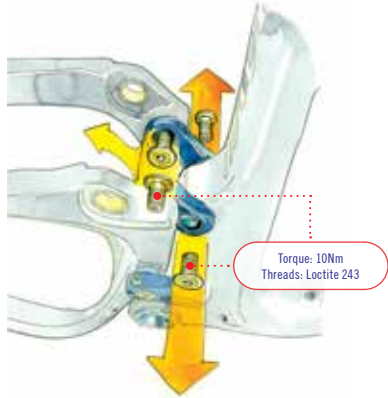

**SWINGARM REMOVAL : MOJO HD4 / MOJO 3**

**DISASSEMBLY / REASSEMBLY**

Put your freshly cleaned Mojo in a work stand, remove cranks, and the rear wheel. Follow steps 1-6 for disassembly, and in reverse order for reassembly.

**PRO TIP:** During reassembly, note the torque specs and thread treatments



**STEP 1**

Remove the shock and clevis assembly by removing the upper shock mount bolt and shaft with two 4mm Allen wrenches\*. Next, remove the clevis to swingarm bolts with a 5mm Allen.

*\*On the upper shock mount, be careful not to lose the thin black washers that go on the outside of the shock eyelet.*

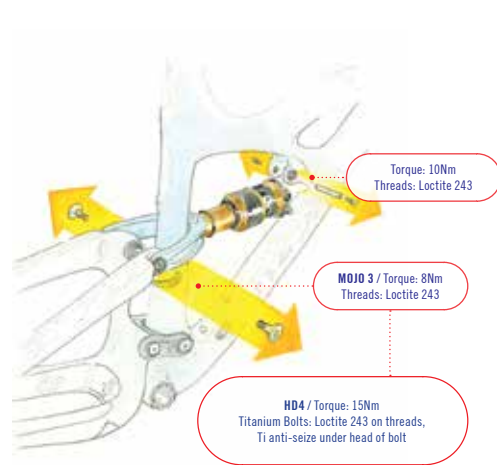

**STEP 2**

Carefully separate the shock and clevis assembly from the frame.

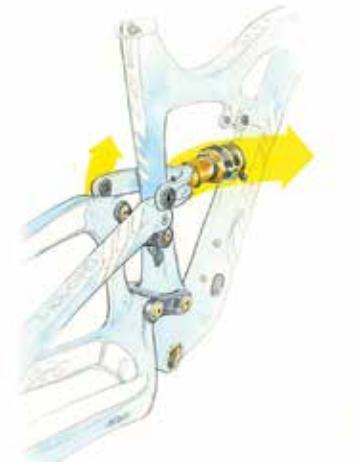

**STEP 3**

Remove the lower shock mount bolt with a 6mm Allen.

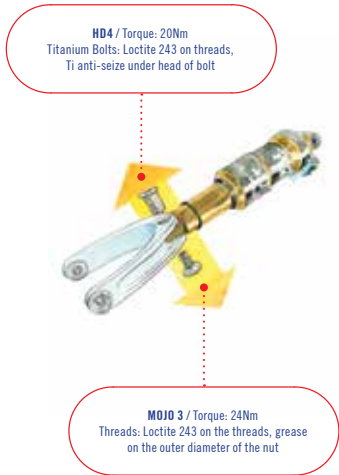

Titanium Bolts: Loctite 243 on threads, Ti anti-seize under head of bolt

**STEP 4**

Remove front lower link shaft and the two forward upper link bolts.

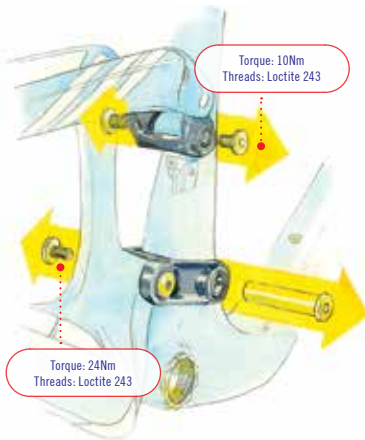
**STEP 5**

Pull the swingarm with the linkages still attached away from the front triangle.

**STEP 6**

Remove the axle in the lower link that passes through the swingarm and separate the link from the swingarm. Also remove the upper link from the swingarm.

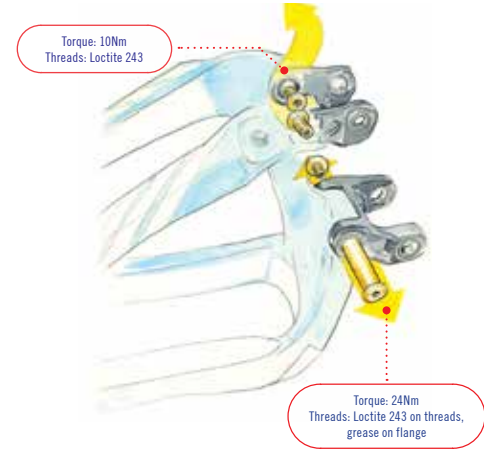

**WARRANTY****FRAME WARRANTY**

7 Year Guarantee - Ibis Frames are guaranteed to be free of defects in materials and workmanship for a period of 7 years for the original owner. Ibis will either repair or replace at its discretion any part it determines to be defective. Paint and finish are covered for a period of 1 year. This warranty is non-transferable and applies exclusively to Ibis bicycles manufactured after January 1, 2016.

Frames manufactured before January 1, 2016, will be covered by this warranty for a period of 3 years for the original owner.

Paint and finish are covered for a period of 1 year. Note that improper removal of protective tape is not covered under our paint warranty. Most protective tape manufacturers have

recommended removal instructions to prevent paint damage. These usually involve, among other things, applying a little heat to soften the adhesive. Check with the manufacturer of the tape before attempting removal!

**RIM WARRANTY**

7 Year Guarantee - Ibis rims are covered from failure due to impact damage under normal riding circumstances for a period of 7 years. This warranty is non-transferable and applies exclusively to Ibis rims manufactured after January 1, 2016

Ibis branded hubs are guaranteed to be free of defects in materials and workmanship for a period of 2 years for the original owner.

**NO FAULT REPLACEMENT**

Should your Ibis product be involved in a crash or other non-warranty situation, Ibis Cycles will make replacement parts available at a minimum charge to the original owner for the life of the product. Ibis Cycles does this at its sole discretion and reserves the right to refuse this offer.

**SMALL PRINT**

The above limited warranties do not cover normal wear and tear, nor does it apply to damage that is the result of blatant abuse, neglect, improper assembly, improper maintenance, alteration, misuse, or heat

damage (watch that exhaust pipe). The costs of disassembly, reassembly or repair of any attached components are not covered by this warranty and are the responsibility of the original owner. Under no circumstance are the costs of shipping to or from Ibis covered by these warranties.

Unless otherwise provided, the sole remedy under the above warranties, or any implied warranty, is limited to the replacement of defective parts with those of equal or greater value at the sole discretion of Ibis Cycles. In no event shall Ibis Cycles be held responsible for direct, incidental or consequential damages, including, without limitation, damages for personal injury, property damage, or economic losses, whether based on contract, warranty, negligence, product liability, or any other theory. Okay? Good!



**WARRANTY REGISTRATION**

Don't forget to register your warranty online at:  
[http://www.ibiscycles.com/support/warranty/warranty\\_registration/](http://www.ibiscycles.com/support/warranty/warranty_registration/)

The Fox forks and shocks we use on our bikes are warranted for one year. For USA Warranty Service:  
**(800) FOX-SHOX / 369-7469**  
 or [service@foxracingshox.com](mailto:service@foxracingshox.com)

**For International Warranty Service**

Contact a Fox service center:  
<http://www.ridefox.com/fox17/contact.php?r=worldwide&ref=service>

**PARTS**

Find these online at the buy portion our website or get them directly from your Ibis dealer. Contact us or your dealer for more info. We recommend you always ride with one or two spare derailleur hangers.

**SERIAL NUMBER**

We recommend you write down your serial number for future reference. The serial number is located under the bottom bracket.

**BIKE INFO**

---

MODEL : \_\_\_\_\_

PAINT COLOR : \_\_\_\_\_

FRONT TRIANGLE SERIAL NO. \_\_\_\_\_

\_\_\_\_\_

SWINGARM SERIAL NO. \_\_\_\_\_

\_\_\_\_\_

**SHOCK SETTINGS**

---

PSI : \_\_\_\_\_

CLICKS REBOUND: \_\_\_\_\_

CLICKS COMPRESSION: \_\_\_\_\_

TUNING NOTES: \_\_\_\_\_

\_\_\_\_\_

\_\_\_\_\_

**FORK SETTINGS**

---

PSI : \_\_\_\_\_

CLICKS REBOUND: \_\_\_\_\_

CLICKS COMPRESSION: \_\_\_\_\_

TUNING NOTES: \_\_\_\_\_

\_\_\_\_\_

\_\_\_\_\_

Specifications and construction details given are not binding. We reserve the right to carry out modifications without prior notice.



**CHUCK'S RECIPE****IMPRESS YOUR RIDING BUDDIES WITH  
CHUCK'S HOMEMADE ENERGY BARS****INGREDIENTS**

- 1/2 cup salted almonds
- 1/2 cup roasted sunflower seeds, or other chopped nuts
- 2 cups raisins, or other chopped dried fruit
- 2 cups rolled or instant oats
- 2 cups toasted rice cereal, such as Rice Krispies
- 1/4 cup toasted wheat germ, (optional)
- 1/2 cup creamy or crunchy natural almond butter
- 1/2 cup packed brown sugar
- 1/2 cup honey (or agave sweetener)
- 1 teaspoon vanilla extract

**PREPARATION**

- 1.** Coat a 9-by-13-inch baking pan with cooking spray.
- 2.** Combine the almonds, sunflower seeds (or other nuts), raisins (or other dried fruit), oats, rice cereal and wheat germ (if using) in a large bowl.

- 3.** Combine almond butter, brown sugar and corn syrup (or honey) in a large microwaveable bowl; microwave on High until bubbling, 1 to 2 minutes. Add vanilla and stir until blended. Pour the almond butter mixture over the dry ingredients and stir until coated.
- 4.** Transfer the mixture to the prepared pan. Press down firmly. (It helps to coat your fingers with cooking spray.) Let stand for about 1 hour to harden. Cut into bars.

**TIPS AND NOTES**

**Make Ahead Tip:** Individually wrap and keep at room temperature for up to 1 week or freeze for up to 1 month. Thaw at room temperature. Makes 16 Bars, better than Method Man in his prime.

**NUTRITION**

Per serving: 255 calories; 9g fat (1g sat., 2g mono); 0 mg cholesterol; 42g carbohydrates; 5g protein; 3g fiber; 95mg sodium; 242mg potassium.

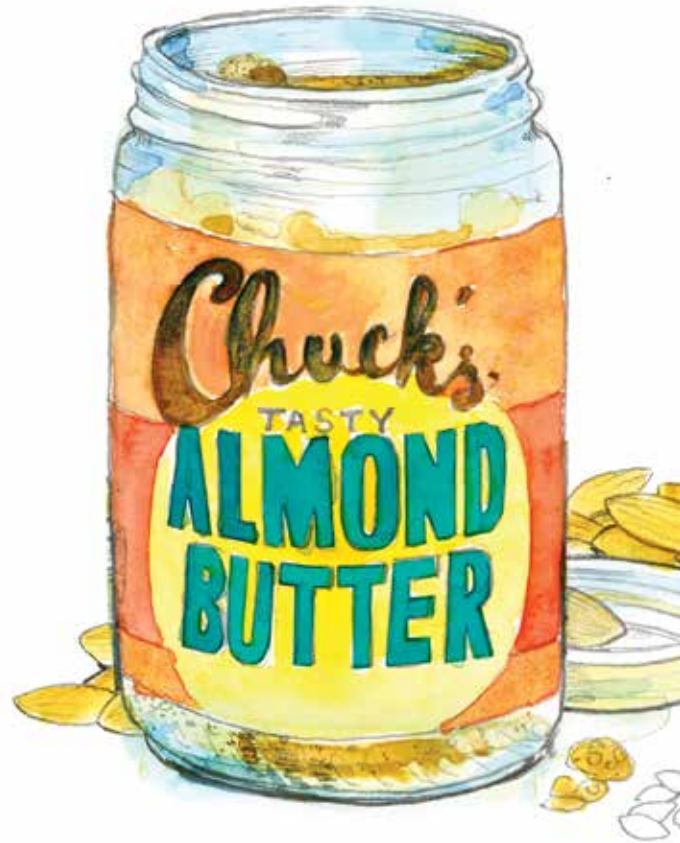

**TOLL FREE** (formerly called an 800 number but all 800's are used up we guess)  
1-866-424-7635 (1-866-IBIS-635)

**NOT TOLL FREE** (unless maybe you're at work)  
1-831-461-1435 (Or if you're all fancy and internationally  
savvy: +1-831-461-1435)

**ELECTRONIC MAIL** (sometimes referred to as "email")  
[askchuck@ibiscycles.com](mailto:askchuck@ibiscycles.com)

**FAX** (remember those?) 1-831-461-1475

**REALLY OLD FASHIONED SNAIL MAIL**  
2240 Delaware Ave. Santa Cruz, CA 95060.

**[IBISCYCLES.COM](http://IBISCYCLES.COM)**

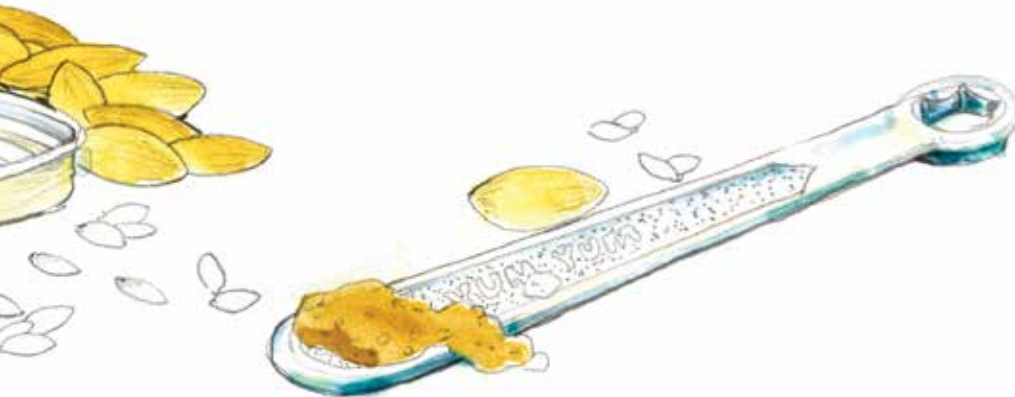

**ALPHABETICAL INDEX**

<b>Airstream</b>	<b>2-3</b>	<b>Hand Job</b>	<b>71</b>
<b>Bearing Specs, Mojo</b>	<b>52</b>	<b>Introduction</b>	<b>2</b>
<b>Bottle Cage</b>	<b>36</b>	<b>ISCG 05</b>	<b>4-5, 17</b>
<b>Cable Routing</b>	<b>10-30</b>	<b>Method Man</b>	<b>66</b>
<b>Cannoli</b>	<b>30</b>	<b>Peanut Butter Wrench</b>	<b>71</b>
<b>Chuck's Recipe</b>	<b>66</b>	<b>Rear Shock Air Pressure Chart</b>	<b>50</b>
<b>Fork Set-up</b>	<b>38-45</b>	<b>Rear Shock Tuning</b>	<b>46-51</b>
<b>Fox Grip2 Settings</b>	<b>42-45</b>	<b>Serial Number</b>	<b>65</b>
<b>Frame Care</b>	<b>36</b>	<b>Snail Mail</b>	<b>67</b>
<b>Frame Hardware Drawings</b>	<b>54-57</b>	<b>Stack and Reach</b>	<b>4-6</b>
<b>Torque Specs</b>	<b>58-59</b>	<b>Swingarm Removal</b>	<b>63</b>
<b>Geometry</b>	<b>4-6</b>	<b>Warranty</b>	<b>64-65</b>





Evolution  
of the  
Opener



Whatever  
Was Around...



the  
Hand Job



On the  
Trail



Standard



Single  
Speed



Das  
Liberator

Maximus ~ not pictured





***[ibiscycles.com](http://ibiscycles.com)***