

# Chemistry Bldg. Explosion

Room 301A

January 12, 2006

# General Information

- Explosion was caused by over-pressurization of liquid nitrogen cylinder
- Explosion occurred between 2 and 3 am
- The explosion caused a water leak in the heating/cooling water for the bldg.
- Physical Plant (P.P.) noticed a drop in water pressure
- P.P. workers were dispatched around the campus to locate the leak, which was found shortly after 6 am.

# Response Groups

- College Station Fire Dept.
- Bryan Fire Dept.
- Physical Plant
- University Police Dept.
- Environmental Health & Safety Dept.
- Chemistry Dept.
- ~ 100 personnel







4<sup>th</sup> Floor











# 2<sup>nd</sup> Floor





# 3<sup>rd</sup> Floor



02 26 8 454 1S7

02 26 8





Room 301A









**FLAMMABLE**  
**KEEP FIRE AWAY**



INFLAMMABLE  
MANTENGASE ALEJADO DEL FUEGO  
INFLAMMABLE  
GARDER LOIN DU FEU

*We have MeOH  
down in stockroom  
in the bag it  
is!!!*

**CAUTION**  
**CORROSIVES**  
EXTREMELY  
CORROSIVE  
POTENTIAL  
CORROSIVES







# Liquid Nitrogen Cylinder Information

FLOW SCHEMATIC

MODEL VGI-160L

FIGURE 1

1. Liquid Valve
2. Economizer Regulator
3. Vent Valve
4. Burst Disc, 425 PSI
5. Pressure Gauge
6. Relief Valve, 235 PSI
7. Pressure Building Regulator
8. Pressure Building Valve
9. Liquid Level Gauge
10. Vacuum Casing Burst Disc
11. Gas Use Valve

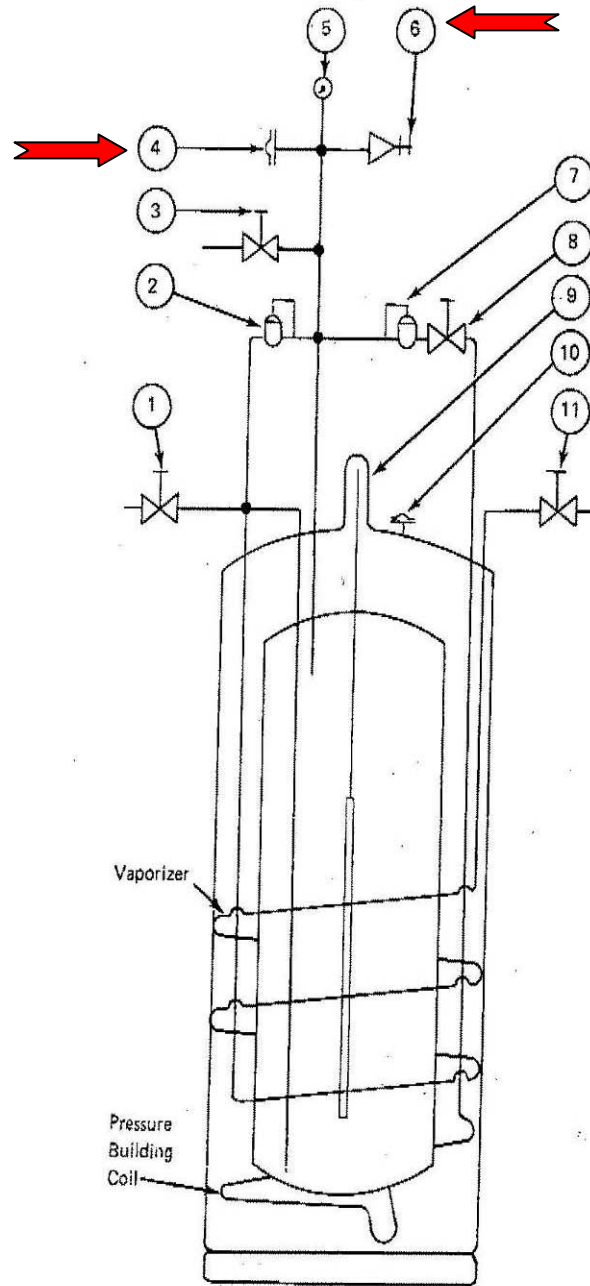





Liquid

Vent

REGO PRESSURE CONTROL VALVE  
OPEN CLOSE

REGO PRESSURE CONTROL VALVE  
OPEN CLOSE

REGO PRESSURE CONTROL VALVE  
OPEN CLOSE



RESEARCH GROUP  
1014





# Hazardous Waste Clean-up

- ~\$10,000 in response equipment and supplies
- \$116,853 for waste consolidation, transportation and disposal
- This does not include any costs for bldg. clean-up or repair by P.P.

# Inspection Program

- Visual inspection of all liquid nitrogen cylinders for pressure relief valves and blowout discs
- Inspect cylinders for signs of over-pressurization
- Replace pressure relief valves every 5 yrs.
- Develop database of all liquid nitrogen cylinders

# Evaluate Lab Safety

- Label chemicals properly
- Install proper safeguards on equipment
- Perform preventive maintenance
- Eliminate electrical hazards
- Know location of nearest fire extinguisher
- Know evacuation routes