

NASA SP-325

The Orbital Mechanics of Flight Mechanics

Robert Scott Dunning

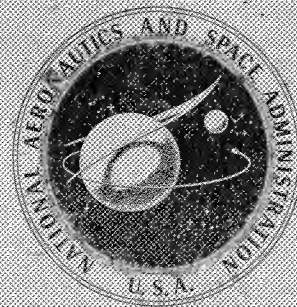

NATIONAL AERONAUTICS AND SPACE ADMINISTRATION

**The Orbital Mechanics
of Flight Mechanics**



L-73-3009

Apollo 9 Landing Module as viewed from the Command Module
in orbit over the earth.

The Orbital Mechanics of Flight Mechanics

Robert Scott Dunning
Langley Research Center

Prepared by NASA Langley Research Center



Scientific and Technical Information Office 1973
NATIONAL AERONAUTICS AND SPACE ADMINISTRATION
Washington, D.C.

For sale by the National Technical Information Service
Springfield, Virginia 22151
Price — Domestic, \$4.75; Foreign, \$7.25
Library of Congress Catalog Card Number 73-600091

PREFACE

Despite the existence of numerous authoritative books in the field of orbital mechanics, the author has felt the need for a book which places emphasis on the conditions encountered with actively controlled satellites and spaceships rather than on observation and analysis of the passive heavenly bodies treated in classical astronomy. Present-day space research, including the use of computers, has made much of the material in previous books outmoded; less emphasis is now placed on closed-form solutions and more on iterative techniques. It is also apparent that a greater emphasis on the basic formulas has become necessary. The problem of relative motion between two vehicles, which was rarely encountered in classical astronomy, has become a routine operational matter today and deserves consideration appropriate to its present importance. Likewise, the atmospheric entry problem for controlled vehicles is new and should be treated. The author has endeavored to use a direct approach to the problems at hand, where possible, and has sought to avoid the cumbersome methods employed by some of the previous works which were dictated in their day by a need to avoid as much arithmetic manipulation as possible. This book is intended, however, not as a competitor but as a supplement to other books.

Although the material covered here is not altogether new, it is scattered in the research literature and is not always readily accessible. The purpose of this book is to provide the reader with a reasonably complete primer on modern dynamic orbit theory. To this end many simple steps, which would seem obvious to the accomplished professional in orbital mechanics or flight dynamics, have been retained. For people already familiar with the subject, it is hoped that the book will provide a useful reference handbook. It should provide a convenient guide for the solution of practical problems encountered in the analysis of space missions or the design of satellites and space vehicles.

To those who are not so accomplished in the field it is hoped that the essentially one-dimensional sequential development which has been adopted will provide a direct access to the fascinating world of modern space dynamics. Starting from the most basic inverse-square law, the law of gravity for a sphere is developed. Then the subject of motion of point masses under the influence of such a sphere is taken up. The first chapter thus serves as a necessary background and covers what is essential to the understanding of the rest of the book in the way of classical orbital theory. The development format used here is thought to be important in that notation is developed which will be used with a fair degree of consistency throughout the rest of the book. In addition, the groundwork for the methodology which will be adopted in succeeding chapters is laid. This methodology consists of a development from the Lagrangian to the resultant equations of motion to the solutions by way of whatever approximations are necessary. It is felt that this is the most direct and error-free way to go. In the event that the Lagrangian formalism may not be familiar to some readers, a suitable starting point is possible at the equations of motion which generally follow the Lagrangian within a few steps. There has been no attempt to place the book in a mathematical straitjacket. Vectors and vector operations are used whenever they seem

to be most appropriate, and thus clearest to the average student of mechanics. Emphasis has been placed on an intuitive feel for the concepts of energy and angular momentum which, it is hoped, most readers have acquired by the time they read this book.

The second chapter is devoted to reentry theory and the relationship between reentry theory and the theory of the orbit. An attempt is made to move the reader away from classical passive observational theory to the developing modern ideas of active spaceships and controlled maneuvers. Emphasis is placed on the character of the gradual transition from pure space flight to pure atmospheric flight. Again, the reader should be constantly aware of the overriding importance of the ideas of angular momentum and energy.

Chapters three and four are concerned with relative motion between two bodies in orbit about the same planet, usually the earth or moon. In chapter three moving rectangular coordinate systems are taken up for the first time. This development leads naturally to the equations of relative motion between two simple point masses and, hence, to the Clohessy-Wiltshire rendezvous equations. The rest of this chapter is devoted to further attempts to improve these equations by the consideration of higher-order terms. In this chapter, perturbation solutions are discussed with emphasis on the physical content rather than on pure mathematical theory.

The main concern of chapter four is also with relative-motion equations. The coordinate systems under consideration, however, are nonrectangular. It will be seen that most of the equations which are expressed in chapter three can be improved considerably in accuracy, or elegance, or both, when the coordinate system is chosen in a way that is more natural to the physical systems under consideration. The first of these systems is spherical and represents very little improvement except for the utility of the approach for certain pieces of hardware. The second system is in shell coordinates, which is essentially a set of cylindrical coordinates with the origin located at some point radially removed from the usual origin. It will be found that this system produces the best long-time or large distance-of-separation accuracy because terms of the series expansions can be retained to higher-order accuracy more readily and handled more easily. Again Clohessy-Wiltshire type rendezvous equations are developed and, in addition, the reasons for physical breakdown of relative-motion equations are carefully explored.

Chapter five reverts to rectangular coordinates and treats the mechanics of simple rigid bodies under the influence of a gravity-gradient field, that is, the difference in gravity between two points in close proximity. By the appropriate use of constraints, this technique affords an introduction to rigid-body dynamics for satellites. A simple dumbbell is analyzed, and then the theory is extended to include the interactions of two dumbbells. This approach allows a logical development to simple rigid-body dynamics including gyroscopic moments. Thus the book essentially covers the ground between point-mass mechanics for a body in orbit and rigid-body dynamics for space vehicles. At this stage, the possible directions of research are open-ended, and a development in terms of moments of inertia, a field which forms a separate

subject for study in itself, becomes natural. With this subject the book is ended. It is emphasized that this is only a beginning and that almost every topic covered in this book affords a jumping-off place for more detailed subsequent research. It is hoped that this book will afford a background for continued improvement in the theory of space mechanics.

CONTENTS

	Page
PREFACE	v
CHAPTER 1 – TWO-BODY MOTION	1
Inertial or Newtonian Reference Frame	3
Newton's Law of Gravity	5
Lagrangian of a Particle in a Gravity Field and Two-Body	
Equations of Motion	6
Equation of a Conic Section	9
Elliptic orbit	11
Circular orbit	13
Parabolic trajectories	14
Hyperbolic trajectories	16
Mean and Eccentric Anomaly	16
Equation of the Center	18
The Orbit in Space	21
CHAPTER 2 – REENTRY THEORY	23
Speed and Flight-Path Angle	25
Lift and Drag	26
The Barometric Equation	27
Solution of the Atmospheric-Entry Equations	30
Variation of flight-path angle γ	35
Variation of the velocity V	35
Variation of range Θ	37
Kepler Formulation of the Entry Equation Incorporating Lift and Drag	39
Energy and Momenta Rates	41
APPENDIX TO CHAPTER 2 – DERIVATION OF EQUATIONS (2-68)	
AND (2-69)	43
CHAPTER 3 – RELATIVE MOTION IN RECTANGULAR COORDINATES	47
Rectangular Coordinates	49
Clohessy-Wiltshire Equations	54
London's Improvement of the Relative-Motion Equations	57
Analysis of Anthony and Sasaki	69
CHAPTER 4 – RELATIVE MOTION IN NONRECTANGULAR COORDINATES	83
Spherical Coordinates	85
Shell Coordinates	89
First-Order Solutions	93
Second-Order Solutions	96
Solution for Y	96
Solution for X	98
Solution for Z	99

	Page
Evaluation of the Integration Constants a and ξ	100
Limitations on the Approximate Solutions	103
Total-Energy Equation	104
Apogee and Perigee Prediction	104
Solutions in Dimensional Notation	104
Physical Interpretation of Terms	107
y-equation	107
x-equation	110
z-equation	110
Test Cases	110
Synchronous case	110
Hohmann case	112
Other launch angles	114
Shell-Coordinate Rendezvous Problem	116
Equations of Sparrow and Price	121
CHAPTER 5 – DYNAMICS OF CONNECTED-POINT MASSES	123
Moments Acting on a Simple Dumbbell in a Right-Handed, Moving, Rectangular Coordinate System	124
Equations of Motion of a Single Dumbbell System	127
Torque Equations of a Double Dumbbell System	129
Natural Gyroscope Coordinates	132
SYMBOLS	139
REFERENCES	145
BIBLIOGRAPHY	146
Books	146
Research Reports	147
INDEX	151

CHAPTER 1
TWO-BODY MOTION

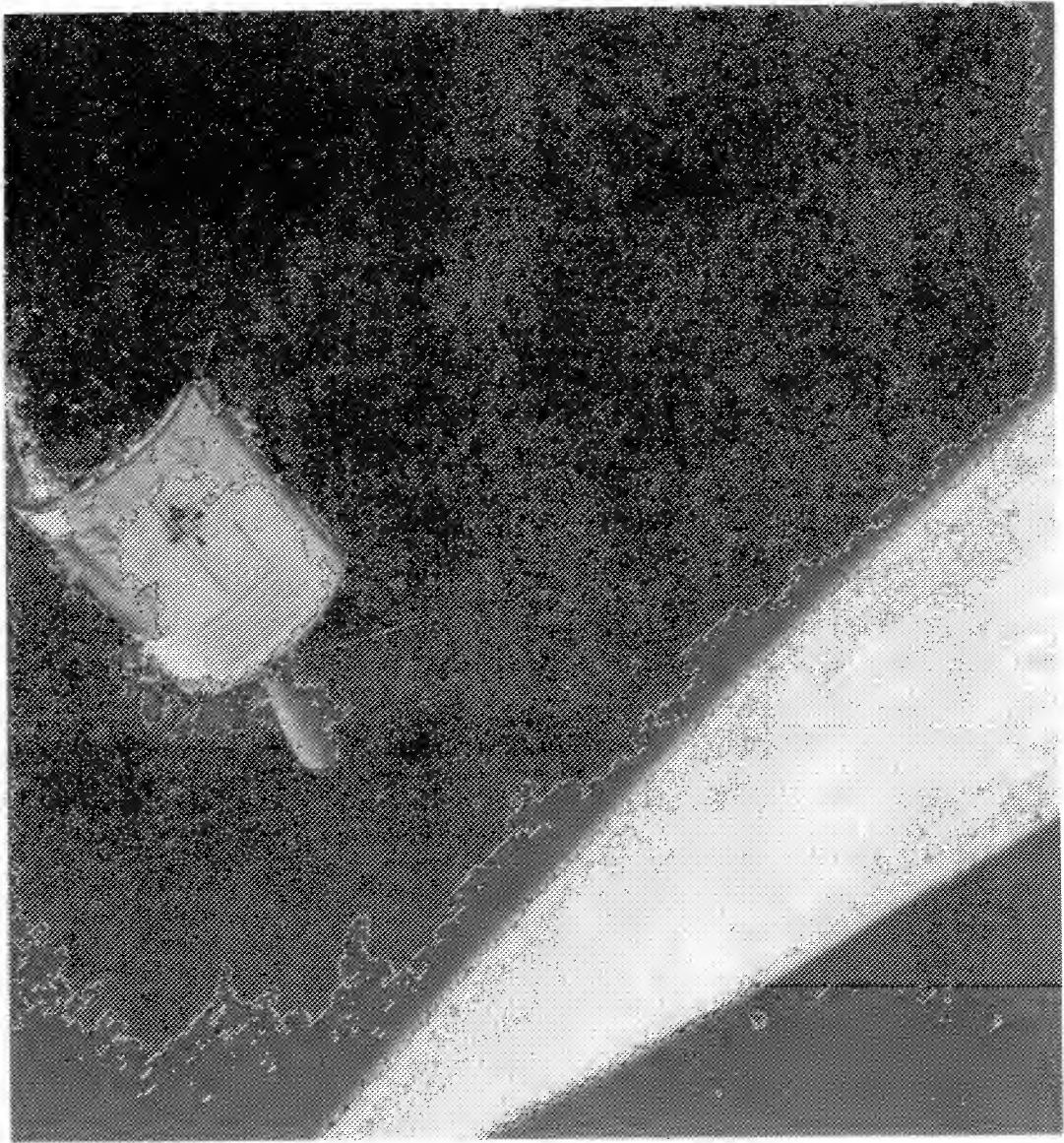

L-73-3010

The Apollo 9 Command/Service Module as photographed in orbit above the earth.

CHAPTER 1

TWO-BODY MOTION

Inertial or Newtonian Reference Frame

Since, to a large extent, the subject matter of this book is devoted to the study of orbital mechanics in a variety of reference frames, the idea of an inertial reference frame will be a central concept. An inertial reference frame was once thought to be one that is fixed relative to absolute space. With the advent of relativistic mechanics the idea of absolute space lost its meaning, and the idea of an inertial frame of reference was shown to be a property peculiar to an individual observer. Attempts were made to define a reference frame which is fixed relative to every body in the universe as an inertial reference frame. This idea is also not satisfactory, however, since every body in the universe seems to be in motion relative to every other body in the universe both in space and time. In addition, the interrelationship of mass and space is not satisfactorily understood at the present time. In the face of this vague foundation, an inertial reference frame will be defined as one in which Newton's laws of motion hold. It may be that in reality no such frame exists. There are situations, however, which approximate such a system. One is a reference frame fixed relative to the center of mass of our galaxy. For a large number of problems, including all of those which will be of interest in this book, a coordinate system fixed relative to the solar system or fixed relative to the center of the earth will be taken as a sufficient approximation to an inertial system.

Assume then that an inertial frame x, y, z exists and suppose it is desired to compute the potential between a unit point particle and a finite rigid body as shown in the following figure:

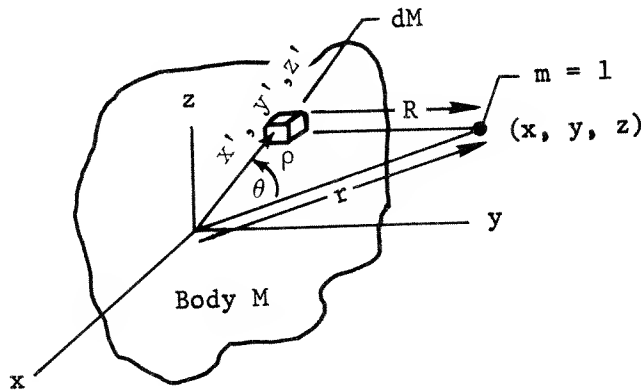

Figure 1-1.- Potential of a finite rigid body.

The potential between the point particles dM and m is defined as

$$u(x, y, z) = G \int_M \frac{dM(x', y', z')}{R(x, y, z; x', y', z')} \quad (1-1)$$

where G is some as yet unknown constant.

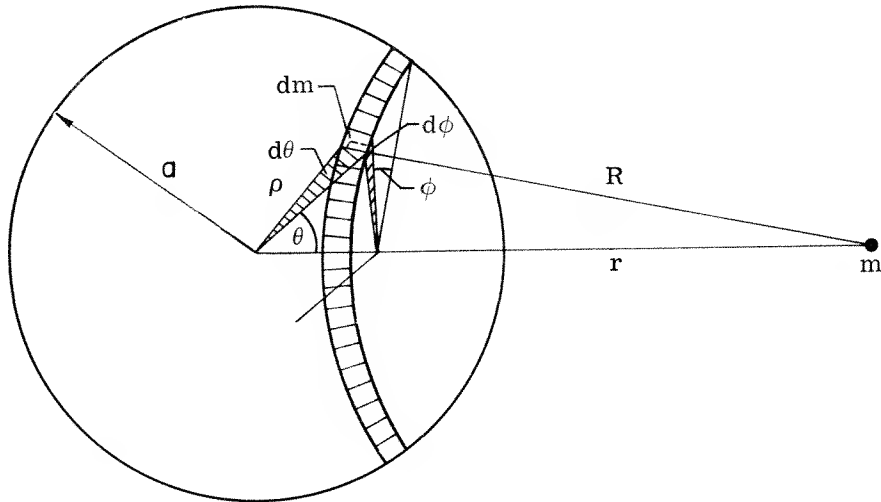

Figure 1-2.- Infinitesimal mass unit and coordinates for computing the potential of a test mass m due to the presence of a sphere.

Suppose now that the body M is a sphere of radius a and uniform density as shown in figure 1-2. Since the sphere is symmetric with respect to both spherical coordinates θ and ϕ , the potential at any point a distance r from the sphere is given by equation (1-1) with

$$dM = \sigma \rho^2 \sin \theta \, d\phi \, d\theta \, d\rho \quad (1-2)$$

$$R^2 = \rho^2 + r^2 - 2\rho r \cos \theta \quad (1-3)$$

where ρ is the radius over which the integration is to be performed and σ is the density of the material of the sphere. Then

$$u = G \int_M \frac{dM}{R} = G \int_0^a \int_0^\pi \int_0^{2\pi} \frac{\sigma \rho^2 \sin \theta \, d\phi \, d\theta \, d\rho}{(\rho^2 + r^2 - 2\rho r \cos \theta)^{1/2}} \quad (1-4)$$

$$= 2\pi \sigma G \int_0^a \int_0^\pi \frac{\rho^2 \sin \theta \, d\theta \, d\rho}{(\rho^2 + r^2 - 2\rho r \cos \theta)^{1/2}} \quad (1-5)$$

In order to facilitate integration at this point, let

$$t = \cos \theta \quad (1-6)$$

$$dt = -\sin \theta \, d\theta \quad (1-7)$$

Then,

$$\begin{aligned}
 u &= -2\pi\sigma G \int_0^a \int_1^{-1} \frac{\rho^2 dt d\rho}{(\rho^2 + r^2 - 2\rho r t)^{1/2}} \\
 &= -2\pi\sigma G \int_0^a \frac{\rho \left[(\rho^2 + r^2 - 2r\rho)^{1/2} - (\rho^2 + r^2 + 2r\rho)^{1/2} \right]}{r} d\rho \\
 &= -\frac{2\pi\sigma G}{r} \int_0^a \rho \left[(r - \rho) - (r + \rho) \right] d\rho \\
 &= \frac{4\pi\sigma G}{r} \int_0^a \rho^2 d\rho = \sigma \left(\frac{4}{3} \pi a^3 \right) \frac{G}{r} = \frac{MG}{r}
 \end{aligned}$$

It can therefore be seen that the potential of a sphere of uniform density is the same as that of a point particle of mass M at the center of the sphere. Thus, spherical planets may be replaced by mass points from the standpoint of dynamics. This procedure will be followed for the most part in subsequent development.

Newton's Law of Gravity

It may be noted that the resultant force per unit mass between M and m is given by

$$\frac{\vec{F}}{m} = -\vec{\nabla}u = -\frac{GM}{r^2} \left(\frac{\vec{r}}{r} \right)$$

acting along a line joining m to M , or

$$\vec{F} = -\frac{GmM}{r^2} \left(\frac{\vec{r}}{r} \right) \tag{1-8}$$

where G will now be defined as the universal gravitational constant. This is, of course, the law of universal gravitation first formulated by Newton:

"Every particle of finite mass in the universe attracts every other particle with a force acting along the line joining them with a magnitude directly proportional to the product of their masses and inversely proportional to the square of the distances of separation."

This law could be taken as a starting point for a theory of orbital mechanics. It was decided to take the potential approach, however, out of deference to field-theory concepts, which seem to be in the ascendancy throughout other branches of mechanics at the present time.

The classical two-body problem is developed next. The starting point for this development will be by means of the Lagrangian of a mass m in a potential field.

Lagrangian of a Particle in a Gravity Field and

Two-Body Equations of Motion

The general expression for the Lagrangian in a noninertial frame of reference without translation is given by

$$L = \frac{1}{2} m \vec{V}^2 + m \vec{V} \cdot \vec{\Omega} \times \vec{r} + \frac{1}{2} m (\vec{\Omega} \times \vec{r})^2 - \frac{\mu}{|\vec{r}|} \quad (1-9)$$

where $\frac{\mu}{|\vec{r}|}$ is defined as the potential energy, \vec{V} is the inertial velocity of m with respect to the center of the potential field μ , and $\vec{\Omega}$ is the rotation vector of the frame of reference. By assuming, for the present, that $\vec{\Omega} = 0$, and hence the coordinate frame is nonrotating, the above equation reduces to the simpler form

$$L = \frac{1}{2} m \vec{V}^2 - \frac{\mu}{|\vec{r}|} \quad (1-10)$$

In a cylindrical coordinate system, with out-of-plane coordinate z ,

$$\vec{V} = \vec{i}\dot{r} + \vec{j}r\dot{\theta} + \vec{k}\dot{z} \quad (1-11)$$

where the out-of-plane magnitude of \vec{r} is given by $|\vec{r}| = (r^2 + z^2)^{1/2}$. The gravitational potential is given by the sum of the potential fields of both m and M .

Hence, in this special case,

$$\frac{\mu}{|\vec{r}|} = -\left(\frac{MG}{|\vec{r}|} + \frac{mG}{|\vec{r}|}\right) \quad (1-12)$$

or

$$\frac{\mu}{|\vec{r}|} = -\frac{G(m+M)}{(r^2 + z^2)^{1/2}} \quad (1-12a)$$

where M is the mass of the central body and m is the mass of a satellite. Equation (1-10) becomes

$$L = \frac{1}{2} m (\dot{r}^2 + r^2 \dot{\theta}^2 + \dot{z}^2) + \frac{G(m+M)}{(r^2 + z^2)^{1/2}} \quad (1-13)$$

The equations of motion which result from this Lagrangian are

$$m\ddot{r} - mr\dot{\theta}^2 + \frac{G(m+M)r}{(r^2 + z^2)^{3/2}} = 0 \quad (1-14)$$

$$mr^2\ddot{\theta} + 2mr\dot{r}\dot{\theta} = 0 \quad (1-15)$$

$$m\ddot{z} + \frac{G(m+M)z}{(r^2 + z^2)^{3/2}} = 0 \quad (1-16)$$

Since G , m , and M are all constant, the gravitational potential at the surface of a planet can be defined by

$$mg_e r_e = \frac{G(M+m)}{r_e} \quad (1-17)$$

where r_e is the radius of the planet and g_e is a derived quantity known as the local gravitational acceleration. Thus, $mg_e r_e$ is the potential energy at a distance r_e from the origin. If g_e is defined in this manner,

$$G(M + m) = mg_e r_e^2 \quad (1-18)$$

If the right-hand side of equation (1-18) is now substituted for the gravitational term in equations (1-14), (1-15), and (1-16), the equations of motion become

$$m\ddot{r} - mr\dot{\theta}^2 + \frac{mg_e r_e^2 r}{(r^2 + z^2)^{3/2}} = 0 \quad (1-19)$$

$$mr^2\ddot{\theta} + 2mr\dot{r}\dot{\theta} = 0 \quad (1-20)$$

$$m\ddot{z} + \frac{mg_e r_e^2 z}{(r^2 + z^2)^{3/2}} = 0 \quad (1-21)$$

These equations completely define two-body orbital motion in an inertial frame of reference. It should be noted that equation (1-20) is actually a torque-balance equation while equations (1-19) and (1-21) are force-balance equations. Equation (1-19) only becomes a force equation when divided by r . The peculiar nature of equation (1-20) is readily seen to be a consequence of the choice of a cylindrical coordinate system.

Integration of equation (1-20) gives the angular momentum associated with the plane containing r and θ :

$$m \frac{d(r^2\dot{\theta})}{dt} = 0 \quad (1-22)$$

Let

$$r^2\dot{\theta} = h \quad (1-23)$$

where h is called the angular momentum per unit mass. From a strict vector viewpoint h is only one of the components of angular momentum, that is, that component formed in the direction of $\vec{i} \times \vec{j} = \vec{k}$ in the notation of equation (1-11). Since this component is conserved irrespective of the other two, however, it is especially valuable in orbital mechanics.

Equations (1-19) and (1-20) can be considerably simplified by assuming that z and \dot{z} are initially zero. If this assumption is made, equation (1-21) remains zero for all time and the motion remains planar. Equation (1-19) becomes

$$m\ddot{r} - mr\dot{\theta}^2 + \frac{mg_e r_e^2}{r^2} = 0 \quad (1-24)$$

Equation (1-20) is not affected by neglecting z and \dot{z} ; so equation (1-23) still applies. Under these conditions there is no angular momentum in the z equation and, since r is radial and so cannot express angular momentum, all of the angular momentum is contained in h . Since it is always possible to select a coordinate

system where the out-of-plane motion is zero initially, all simple orbits can be treated as planar so long as there is no acceleration acting in the out-of-plane direction.

Substituting the right-hand side of equation (1-23) into equation (1-24) uncouples the latter, thus giving

$$m\ddot{r} - m \frac{h^2}{r^3} + \frac{mg_e r_e^2}{r^2} = 0 \quad (1-25)$$

This equation can be multiplied through by \dot{r} and integrated to yield

$$\frac{1}{2} m \dot{r}^2 + \frac{1}{2} m \frac{h^2}{r^2} - \frac{mg_e r_e^2}{r} = \text{Constant} \quad (1-26)$$

Let the integration constant be designated by mH . The left side is the law of conservation of energy, so H is the energy per unit mass and mH is the total energy.

Thus

$$\frac{1}{2} m \dot{r}^2 + \frac{1}{2} m \frac{h^2}{r^2} - \frac{mg_e r_e^2}{r} = mH \quad (1-27)$$

The orbital speed at any given radius may be found from equation (1-27). If V is speed,

$$\frac{1}{2} m V^2 = \frac{1}{2} m \left[\dot{r}^2 + (r\dot{\theta})^2 \right] \quad (1-28)$$

Then using the left-hand side of equation (1-28) in equation (1-27) and dropping the common m

$$\frac{1}{2} V^2 = H + \frac{g_e r_e^2}{r} \quad (1-29)$$

for all orbits.

By setting $\dot{r} = 0$ the existence of extremal distances can be investigated. Equation (1-27) is solved for r to give

$$r_{a,p} = \frac{-1 \pm \sqrt{1 + \frac{2h^2 H}{g_e^2 r_e^4}}}{2H/g_e r_e^2} \quad (1-30)$$

It can be seen, since g_e and r_e are always positive and h is even-powered, that the sign of H governs the nature of the orbit in a distinctive manner. If H is zero or positive, there can be only one positive nonzero extremal. If H is negative, there are two real values. In this case the positive sign of the radical gives an expression for minimum distance from the origin r_p , the perigee radius, while the negative sign gives the maximum distance r_a , the apogee radius.

Equation of a Conic Section

Equation (1-27) can be integrated with a change of independent variable from t to θ to obtain the classic equation of a conic section. By equation (1-23)

$$\dot{\theta} = \frac{h}{r^2} \quad (1-23)$$

So

$$\dot{r} = \frac{h}{r^2} \frac{dr}{d\theta} \quad (1-31)$$

Equation (1-27) becomes, after some rearrangement,

$$\left(\frac{dr}{d\theta}\right)^2 = r^2 \left[\left(\frac{2H}{h^2}\right)r^2 + \left(\frac{2g_e r_e^2}{h^2}\right)r - 1 \right] \quad (1-32)$$

Taking the square root, the variables separate to give

$$d\theta = \frac{dr}{r \left[\left(\frac{2H}{h^2}\right)r^2 + \left(\frac{2g_e r_e^2}{h^2}\right)r - 1 \right]^{1/2}} \quad (1-33)$$

This equation can be integrated directly (ref. 1) to give

$$\theta - \theta_0 = \cos^{-1} \left[\frac{\frac{h^2}{r} - g_e r_e^2}{\left(g_e^2 r_e^4 + 2h^2 H\right)^{1/2}} \right] \quad (1-34)$$

where θ_0 is an integration constant. If this equation is solved for r , one obtains

$$r = \frac{h^2/g_e r_e^2}{1 + \left(1 + \frac{2h^2 H}{g_e^2 r_e^4}\right)^{1/2} \cos(\theta - \theta_0)} \quad (1-35)$$

Setting

$$p = \frac{h^2}{g_e r_e^2} \quad (1-36)$$

which is called the semilatus rectum and, if ϵ is defined by

$$\epsilon = \left(1 + \frac{2h^2 H}{g_e^2 r_e^4}\right)^{1/2} \quad (1-37)$$

equation (1-35) becomes

$$r = \frac{p}{1 + \epsilon \cos(\theta - \theta_0)} \quad (1-38)$$

Examples of typical solutions of equation (1-38) with p set equal to one are shown in figure 1-3. The same information in more familiar rectangular coordinates is

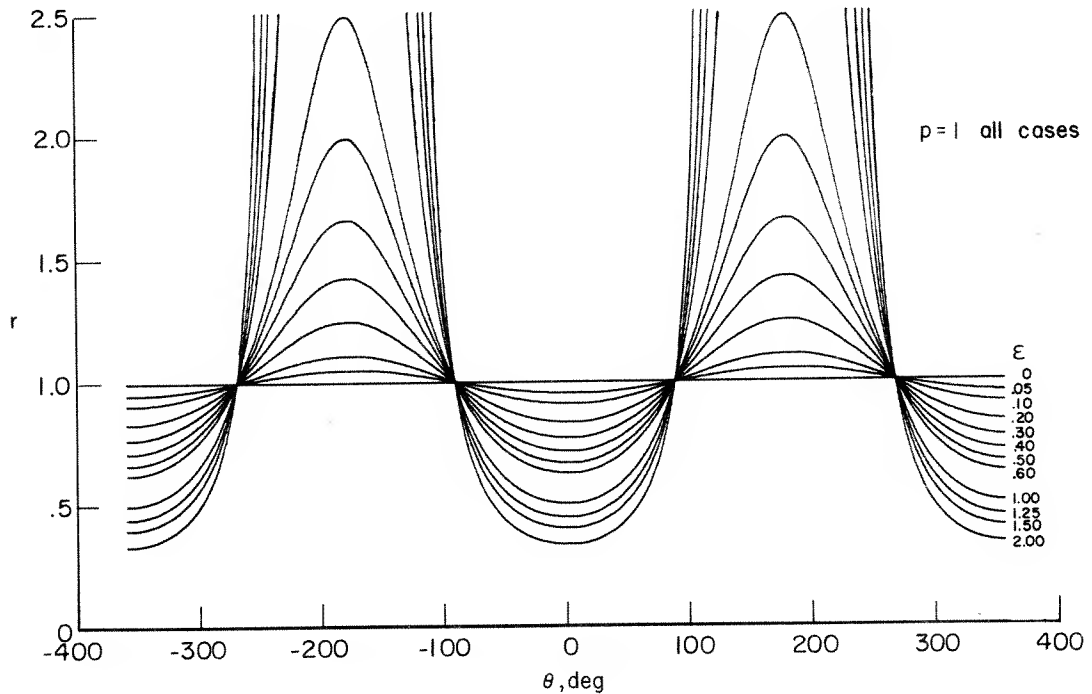

Figure 1-3.- Typical conic sections in nondimensional form. Radial distance plotted against angle in degrees.

shown in figure 1-4. Equation (1-38) is a standard form of a conic section with the origin at one focus and eccentricity ϵ . The three types of orbit suggested by equation (1-30) can now be classified by the value of the eccentricity ϵ :

If $0 \leq \epsilon < 1$, the orbit is an ellipse

If $\epsilon = 1$, the orbit is a parabola

If $\epsilon > 1$, the orbit is a hyperbola

In the special case where $\epsilon = 0$ equation (1-38) reduces to the equation of a circle.

These cases will now be examined in detail with special consideration given to the elliptic case since this is the most important case from an astrodynamic point of view.

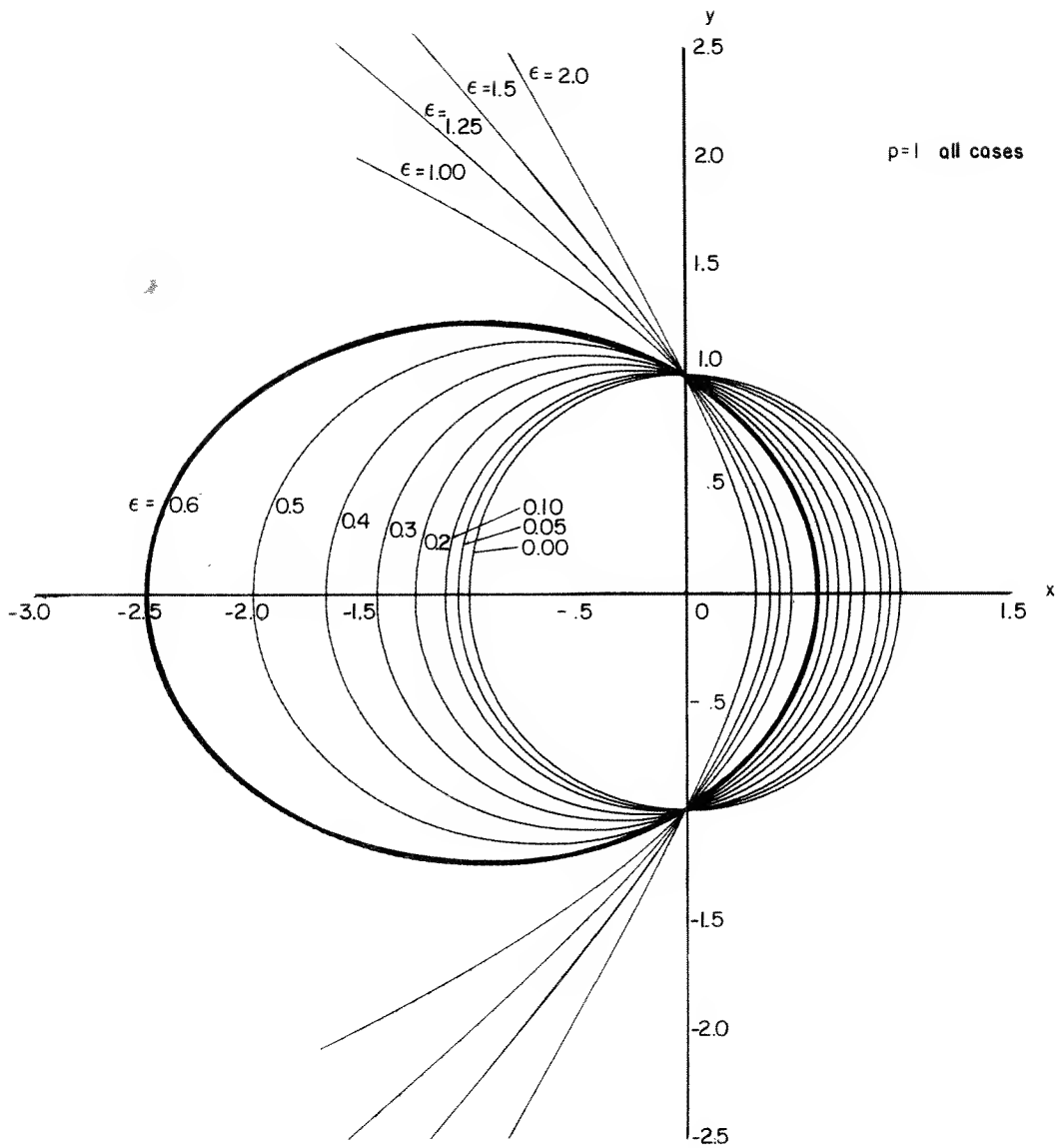

Figure 1-4.- Conic sections in rectangular coordinates.

Elliptic orbit. - In the first case above

$$0 < \epsilon = \left(1 + \frac{2h^2 H}{g_e^2 r_e^4} \right)^{1/2} < 1 \quad (1-39)$$

or

$$\frac{2h^2 H}{g_e^2 r_e^4} < 0 \quad (1-40)$$

Since h , g_e , and r_e are all even-powered, H must be negative; that is, the total energy per unit mass (with respect to a zero potential infinite point) is negative for an elliptic orbit, and the spacecraft is trapped in a potential well.

The next step is to calculate the period of an elliptic orbit. This period is frequently obtained by introducing coordinates associated with the geometric center of the ellipse and making an appropriate transformation. The period is then found in terms of the semimajor axis distance. A more direct, though algebraically more involved, method is to calculate the area of the ellipse divided by the rate at which area is swept out by the r vector. In this instance the orbital period P is

$$P = \int_0^P dt = \int_0^{2\pi} \frac{d\theta}{\dot{\theta}} = \int_0^{2\pi} \frac{r^2 d\theta}{r^2 \dot{\theta}} = \int_0^{2\pi} \frac{r^2}{h} d\theta \quad (1-41)$$

The numerator of the above expression is found by multiplying equation (1-33) by r^2

$$r^2 d\theta = \frac{r dr}{\left[\left(\frac{2H}{h^2} \right) r^2 + \left(\frac{2g_e r_e^2}{h^2} \right) r - 1 \right]^{1/2}} \quad (1-42)$$

Hence, taking advantage of symmetry over r in the limits

$$P = \int_0^{2\pi} \frac{r^2 d\theta}{h} = \frac{2}{h} \int_{r_p}^{r_a} \frac{r dr}{\left[\left(\frac{2H}{h^2} \right) r^2 + \left(\frac{2g_e r_e^2}{h^2} \right) r - 1 \right]^{1/2}} \quad (1-43)$$

where r_a is apogee and r_p is perigee.

It can be seen that by applying the limits in the above equations a tacit assumption is made that the orbit is closed and hence is an ellipse. Integrating from tables

$$P = \frac{h}{H} \left[\left(\frac{2H}{h^2} \right) r_a^2 + \left(\frac{2g_e r_e^2}{h^2} \right) r_a - 1 \right]^{1/2} \Bigg|_{r_p}^{r_a} + \frac{g_e r_e^2}{H\sqrt{-2H}} \sin^{-1} \left[\frac{2Hr + g_e r_e^2}{\left(2Hh^2 + g_e^2 r_e^4 \right)^{1/2}} \right] \Bigg|_{r_p}^{r_a} \quad (1-44)$$

$$P = \frac{h}{H} \left[\left(\frac{2H}{h^2} \right) r_a^2 + \left(\frac{2g_e r_e^2}{h^2} \right) r_a - 1 \right]^{1/2} - \frac{h}{H} \left[\left(\frac{2H}{h^2} \right) r_p^2 + \left(\frac{2g_e r_e^2}{h^2} \right) r_p - 1 \right]^{1/2} + \frac{g_e r_e^2}{H\sqrt{-2H}} \sin^{-1} \left[\frac{2Hr_a + g_e r_e^2}{\left(2Hh^2 + g_e^2 r_e^4 \right)^{1/2}} \right] - \frac{g_e r_e^2}{H\sqrt{-2H}} \sin^{-1} \left[\frac{2Hr_p + g_e r_e^2}{\left(2Hh^2 + g_e^2 r_e^4 \right)^{1/2}} \right] \quad (1-45)$$

Then, making use of the values of r_a and r_p in equation (1-30) the first two terms in equation (1-45) vanish and the second two terms reduce to

$$P = -\frac{g_e r_e^2}{H\sqrt{-2H}} \sin^{-1}(1) + \frac{g_e r_e^2}{H\sqrt{-2H}} \sin^{-1}(-1) = -\frac{g_e r_e^2 \pi}{H\sqrt{-2H}} \quad (1-46)$$

A negative period, of course, corresponds to a reversal of direction or of time; hence only the absolute value is of physical interest. This equation brings out the fact that the period of an orbit depends only upon the total energy of the orbiting body and the strength of the gravity field of the attracting planet.

The semimajor axis of an ellipse a is given by one-half the sum of the perigee radius and the apogee radius. Again making use of equation (1-30)

$$a = \frac{r_a + r_p}{2} = \frac{1}{2} \left(\frac{-g_e r_e^2 - \sqrt{g_e^2 r_e^4 + 2Hh^2}}{2H} + \frac{-g_e r_e^2 + \sqrt{g_e^2 r_e^4 + 2Hh^2}}{2H} \right) = -\frac{g_e r_e^2}{2H} \quad (1-47)$$

The period in terms of the semimajor axis becomes

$$P = \frac{2\pi}{\sqrt{-2H}} \left(\frac{-g_e r_e^2}{2H} \right) = \frac{2\pi a}{\sqrt{-2H}} = 2\pi \sqrt{\frac{a^3}{g_e r_e^2}} \quad (1-48)$$

It can be seen that the period becomes a function of either (a, H) or $(a, g_e r_e^2)$. About a given planet, any two orbits having the same energy and semimajor axis are synchronous. This will be found to be important in the study of rendezvous problems.

From equation (1-36) it can be seen by rewriting the equation that

$$p = -\frac{g_e r_e^2}{2H} \left[1 - \left(1 + \frac{2h^2 H}{g_e^2 r_e^4} \right) \right] = -\frac{g_e r_e^2}{2H} (1 - \epsilon^2) \quad (1-36a)$$

And so, from equation (1-47)

$$p = a(1 - \epsilon^2)$$

Thus equation (1-38) can be written for an elliptic orbit in the useful form

$$r = \frac{a(1 - \epsilon^2)}{1 + \epsilon \cos(\theta - \theta_0)} \quad (1-38a)$$

Circular orbit.- A special case of an elliptic orbit is a circular orbit. In this kind of orbit $\epsilon = 0$ and equation (1-35) reduces to

$$r_{\text{cir}} = \frac{h^2}{g_e r_e^2} = \text{Constant} \quad (1-49)$$

The energy of a circular orbit can be found from equation (1-37). Since ϵ is zero

$$H = -\frac{g_e^2 r_e^4}{2h^2} = -\frac{g_e r_e^2}{2r_{\text{cir}}} \quad (1-50)$$

The speed is found very simply from equation (1-29) and is

$$\frac{1}{2} V_{\text{cir}}^2 = \frac{1}{2} \frac{g_e r_e^2}{r_{\text{cir}}}$$

or

$$V_{\text{cir}} = \sqrt{\frac{g_e r_e^2}{r_{\text{cir}}}} \quad (1-51)$$

The angular momentum can also be established from equation (1-50) and is given by

$$h_{\text{cir}} = r_{\text{cir}} \sqrt{\frac{g_e r_e^2}{r_{\text{cir}}}} = r_{\text{cir}} V_{\text{cir}} \quad (1-52)$$

Hence it can be seen that $\dot{\theta}$ is constant. Denoting this constant by ω gives

$$h_{\text{cir}} = r_{\text{cir}}^2 \omega = r_{\text{cir}} \sqrt{\frac{g_e r_e^2}{r_{\text{cir}}}} \quad (1-53)$$

Hence

$$\omega = \sqrt{\frac{g_e r_e^2}{r_{\text{cir}}^3}} \quad (1-54)$$

All of the other important relations for circular orbits can be derived in a similar manner from the appropriate elliptic equations.

Parabolic trajectories.- For parabolic trajectories $\epsilon = 1$; therefore, from equation (1-37)

$$\frac{2h^2 H}{g_e^2 r_e^4} = 0 \quad (1-55)$$

and from equation (1-35)

$$r = \frac{h^2 / g_e r_e^2}{1 + \cos(\theta - \theta_0)} \quad (1-56)$$

Since h^2 and $g_e^2 r_e^4$ are finite, and nonzero, the total energy, from equation (1-55), is zero; thus

$$H = 0 \quad (1-57)$$

The zero total-energy state could be considered the main distinguishing feature of a parabolic orbit. The speed is found again from equation (1-29) and is

$$\frac{1}{2} V_{\text{parabolic}}^2 = \frac{g_e r_e^2}{r}$$

or

$$V_{\text{parabolic}} = \sqrt{\frac{2g_e r_e^2}{r}} \quad (1-58)$$

A simple and useful relation can be found between circular and parabolic speeds by comparing equations (1-51) and (1-58) for trajectories at the same altitude. If

$$r = r_{\text{cir}},$$

$$\frac{V_{\text{parabolic}}}{V_{\text{circular}}} = \sqrt{2} \quad (1-59)$$

The minimum distance from the origin for a parabolic trajectory occurs when $\dot{r} = 0$. From equation (1-27) by setting the time derivative of r equal to zero

$$r_{\text{min}} = \frac{h^2}{2g_e r_e^2} \quad (1-60)$$

Thus, if one wishes to inject a vehicle from circular orbit to a parabolic trajectory by thrusting tangent to the orbit, the required angular momentum is

$$h_{\text{parabolic}} = r_{\text{min}} \sqrt{\frac{2g_e r_e^2}{r_{\text{min}}}} \quad (1-61)$$

The ratio of angular momenta can also be found. From equations (1-53) and (1-61),

$$\frac{h_{\text{parabolic}}}{h_{\text{circular}}} = \sqrt{2} \quad (1-62)$$

The difference in angular momentum between $h_{\text{parabolic}}$ and h_{circular} is given by slight rearrangement, making use of equation (1-52)

$$h_{\text{parabolic}} - h_{\text{circular}} = (\sqrt{2} - 1)r_{\text{cir}} \sqrt{\frac{g_e r_e^2}{r_{\text{cir}}}} \quad (1-63)$$

A parabolic trajectory has the property that a body on such a trajectory has just barely enough speed to escape from the gravitational field of the attracting planet. Thus these trajectories are often called minimum-escape trajectories. Such trajectories are not encountered very often in actual practice. However, bodies entering the solar system with essentially zero velocity relative to the sun are found to approximate this situation fairly well. Included among these are a large class of comets. Since these bodies return to the same distance from which they start, comets in perfectly parabolic orbits are observed only once. Due to minor energy losses, however, some of these bodies are trapped by the solar system and thereafter assume highly elongated elliptic orbits. Under these conditions, they periodically return to the vicinity of the sun.

Many meteorites are also presumably on parabolic trajectories with respect to the earth. They travel around the sun in essentially the same orbit as the earth until

they encounter the earth's gravity field. In this case, few of the observed ones survive an encounter with the earth.

Hyperbolic trajectories.- Hyperbolic trajectories are important in interplanetary work because bodies in such orbits travel with speeds in excess of minimum-escape speed. Up until the present time no such trajectories have been attempted relative to the solar system owing to the high energies involved with respect to the energy level of the earth. Such trajectories are important in interplanetary work, however, since they allow the shortest travel times between planets. Of course, any interplanetary probe leaves the vicinity of the earth along a hyperbolic trajectory with respect to the earth itself.

For a hyperbolic trajectory $\epsilon > 1$; therefore,

$$\left(1 + \frac{2h^2 H}{g_e^2 r_e^4}\right)^{1/2} > 1 \quad (1-64)$$

Since, as before, h , g_e , and r_e are all even-powered, H must be positive; that is, the total energy per unit mass (with respect to a zero potential infinite point) is positive, and a spacecraft has the capability of leaving the local gravitational potential well. A body having such energy with respect to a planet's gravitational field escapes into the solar system; a body having such potential energy with respect to the sun's gravitational field escapes from the solar system into interstellar space.

Equation (1-35) applies as in the case of an ellipse although the results are, of course, quite different, as zero denominators are possible. Thus

$$r = \frac{h^2/g_e r_e^2}{1 + \left(1 + \frac{2h^2 H}{g_e^2 r_e^4}\right)^{1/2} \cos(\theta - \theta_0)} \quad (1-35)$$

The concept of period is meaningless, as such orbits are not cyclic.

Mean and Eccentric Anomaly

The mean motion of a satellite in elliptic orbit is defined as

$$n = \frac{2\pi}{P} = \frac{2H\sqrt{-2H}}{-g_e r_e^2} \quad (1-65)$$

or, expressed in terms of the semimajor axis, from (1-47)

$$n = \sqrt{\frac{g_e r_e^2}{a^3}} \quad (1-66)$$

This is the rate at which an orbiting spacecraft would have to move if its angular velocity were constant in order to complete one orbit in time P . The mean angle traveled from some arbitrary starting time t_0 would then be

$$M = n(t - t_0) = \frac{2H\sqrt{-2H}(t - t_0)}{-g_e r_e^2} \quad (1-67)$$

The eccentric anomaly E , described in figure 1-5, is defined by the transcendental equation

$$E - \epsilon \sin E = M = \frac{2H\sqrt{-2H}}{-g_e r_e^2}(t - t_0) \quad (1-68)$$

or, in terms of the semimajor axis,

$$E - \epsilon \sin E = M = \frac{\sqrt{g_e r_e}(t - t_0)}{a^{3/2}} = n(t - t_0) \quad (1-69)$$

This equation is called Kepler's equation.

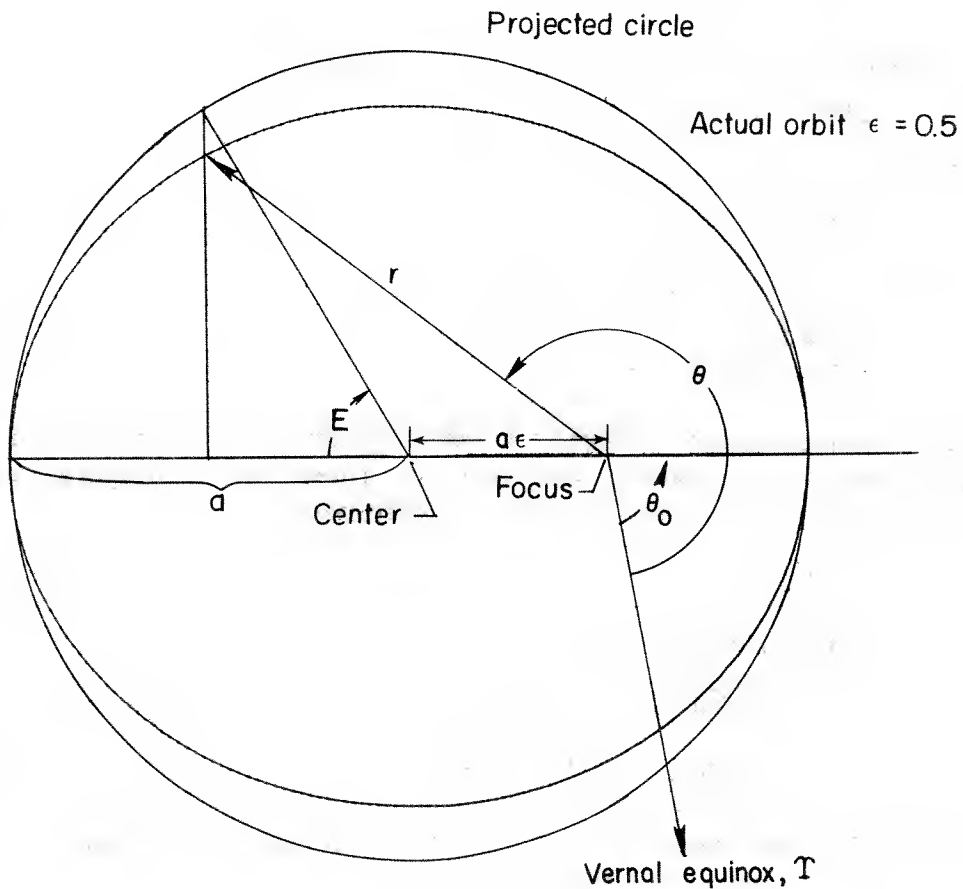

Figure 1-5.- Eccentric anomaly description.

Equation of the Center

Equation (1-69) can be used to derive an important series expansion of an ellipse called the equation of the center which will be needed in chapter 3. The partial derivative of equation (1-69) with respect to the eccentricity is given by

$$\frac{\partial E}{\partial \epsilon} - \sin E - \epsilon \cos E \frac{\partial E}{\partial \epsilon} = \frac{\partial M}{\partial \epsilon} \quad (1-70)$$

From the second equality in equation (1-69), it can be seen that

$$\frac{\partial M}{\partial \epsilon} = \frac{\partial}{\partial \epsilon} \left[\frac{\sqrt{g_e r_e}}{a^{3/2}} (t - t_0) \right] = 0 \quad (1-71)$$

so that

$$(1 - \epsilon \cos E) \frac{\partial E}{\partial \epsilon} - \sin E = 0$$

or

$$\epsilon \frac{\partial E}{\partial \epsilon} = \frac{\epsilon \sin E}{1 - \epsilon \cos E} \quad (1-72)$$

Also, from equation (1-69) the exact differential is given by

$$dM = (1 - \epsilon \cos E)dE \quad (1-73)$$

Equations (1-72) and (1-73) can be combined to give

$$\epsilon \frac{\partial E}{\partial \epsilon} dM = \epsilon \sin E dE \quad (1-74)$$

This equation can be integrated over M to give

$$\epsilon \int_0^M \frac{\partial E}{\partial \epsilon} dM = -\epsilon \cos E + C \quad (1-75)$$

where C is an integration constant. In order to perform this integration, it is necessary to expand E in a series of terms in M . To facilitate the integration to sufficient accuracy, solve equation (1-69) in a nested expression:

$$E = M + \epsilon \sin E$$

but

$$\begin{aligned} \sin E &= \sin(M + \epsilon \sin E) \\ &= \sin[M + \epsilon \sin(M + \epsilon \sin E)] \\ &= \sin[M + \epsilon \sin(M + \epsilon \sin((. . .)))]) \end{aligned} \quad (1-76)$$

Then apply the trigonometric identity for the sine of the sum of two angles

$$\sin(A + B) = \sin A \cos B + \cos A \sin B$$

to obtain

$$E = M + \epsilon \sin M \left[\cos(\epsilon \sin(M + \epsilon \sin(\dots))) \right] \\ + \epsilon \cos M \left[\sin(\epsilon \sin(M + \epsilon \sin(\dots))) \right] \quad (1-77)$$

But for small eccentricity this equation becomes, approximately (ref. 2)

$$E \approx M + \epsilon \sin M + \epsilon^2 \cos M \sin M + \text{Higher-order terms}$$

so

$$E \approx M + \epsilon \sin M + \frac{\epsilon^2}{2} \sin 2M + \text{Higher-order terms} \quad (1-78)$$

The partial derivative of equation (1-78) with respect to ϵ can then be applied in equation (1-75), resulting in

$$-\epsilon \cos E = C + \epsilon \int_0^M (\sin M + \epsilon \sin 2M + \dots) dM \quad (1-79)$$

where C is still an undetermined constant. From figure 1-5

$$a\epsilon + r \cos(\theta - \theta_0) = a \cos E \quad (1-80)$$

and from equation (1-38a)

$$r = \frac{a(1 - \epsilon^2)}{1 + \epsilon \cos(\theta - \theta_0)} \quad (1-38a)$$

If $(\theta - \theta_0)$ is eliminated between these two equations, the equation of an ellipse in polar form is given by

$$r = a(1 - \epsilon \cos E) \quad (1-81)$$

Hence

$$-\epsilon \cos E = \frac{r}{a} - 1$$

Substituting this value for the term on the left in equation (1-79)

$$\frac{r}{a} = 1 + C + \epsilon \int_0^M (\sin M + \epsilon \sin 2M + \dots) dM \quad (1-82)$$

or, integrating,

$$\frac{r}{a} = 1 + C - \epsilon \cos M - \frac{1}{2} \epsilon^2 \cos 2M \quad (1-83)$$

If it is assumed that the series is uniformly convergent for small eccentricity, this equation can again be integrated between the limits $M = 0$ and $M = 2\pi$:

$$\int_0^{2\pi} \frac{r}{a} dM = 2\pi(1 + C) - \epsilon \int_0^{2\pi} \cos M dM - \frac{\epsilon^2}{2} \int_0^{2\pi} \cos(2M) dM \quad (1-84)$$

The two right-hand trigonometric terms vanish and

$$\int_0^{2\pi} \frac{r}{a} dM = 2\pi(1 + C) \quad (1 - 85)$$

The left-hand side is evaluated by reverting back to eccentric anomaly form, noting that the limit remains unchanged,

$$\int_0^{2\pi} (1 - \epsilon \cos E)^2 dE = 2\pi \left(1 + \frac{\epsilon^2}{2}\right) \quad (1-86)$$

Thus

$$2\pi \left(1 + \frac{\epsilon^2}{2}\right) = 2\pi(1 + C)$$

and

$$C = \frac{\epsilon^2}{2} \quad (1-87)$$

Then

$$\frac{r}{a} = 1 - \epsilon \cos M - \frac{1}{2} \epsilon^2 (\cos 2M - 1) + \text{Higher-order terms} \quad (1-88)$$

The computation of the appropriate series for θ follows from this equation and equations (1-38a) and (1-69). By eliminating r between (1-88) and (1-38a)

$$1 - \epsilon \cos E = \frac{1 - \epsilon^2}{1 + \epsilon \cos(\theta - \theta_0)} \quad (1-89)$$

This equation can be solved for $\cos(\theta - \theta_0)$ by rearrangement

$$\cos(\theta - \theta_0) = \frac{\cos E - \epsilon}{1 - \epsilon \cos E} \quad (1-90)$$

and can also be converted to sine form, which is

$$\sin(\theta - \theta_0) = \frac{(1 - \epsilon^2)^{1/2} \sin E}{1 - \epsilon \cos E} \quad (1-91)$$

Equation (1-90) can then be differentiated with respect to E

$$\sin(\theta - \theta_0) d\theta = \frac{(1 - \epsilon^2) \sin E dE}{(1 - \epsilon \cos E)^2} \quad (1-92)$$

Elimination of $\sin(\theta - \theta_0)$ between equations (1-91) and (1-92) results in

$$d\theta = \frac{(1 - \epsilon^2)^{1/2} (1 - \epsilon \cos E) dE}{(1 - \epsilon \cos E)^2} \quad (1-93)$$

which is, from Kepler's equation, equation (1-73),

$$d\theta = \frac{(1 - \epsilon^2)^{1/2}}{(1 - \epsilon \cos E)^2} dM \quad (1-94)$$

This equation becomes, as a consequence of Kepler's equation,

$$d\theta = \sqrt{1 - \epsilon^2} \left(\frac{dE}{dM}\right)^2 dM \quad (1-95)$$

The quantity dE/dM is found at once from the expression for E in terms of M , equation (1-78), by taking the derivative of E with respect to M ,

$$d\theta = (1 - \epsilon^2)^{1/2} (1 + \epsilon \cos M + \epsilon^2 \cos 2M)^2 dM \quad (1-96)$$

Then, after expanding $(1 - \epsilon^2)^{1/2}$ in the power series

$$(1 - \epsilon^2)^{1/2} = 1 - \frac{\epsilon^2}{2} + \text{Higher-order terms} \quad (1-97)$$

$$\begin{aligned} d\theta &= \left(1 - \frac{\epsilon^2}{2}\right) \left[(1 + \epsilon \cos M + \epsilon^2 \cos 2M)^2 + \text{Higher-order terms} \right] dM \\ &= \left(1 - \frac{\epsilon^2}{2}\right) \left[1 + 2\epsilon \cos M + \epsilon^2 \left(2 \cos 2M + \frac{1}{2} \cos 2M + \frac{1}{2} \right) + \text{Higher-order terms} \right] dM \\ &\approx \left(1 + 2\epsilon \cos M + \frac{5}{2} \epsilon^2 \cos 2M \right) dM \end{aligned} \quad (1-98)$$

Integrating with respect to M ,

$$\theta = M + 2\epsilon \sin M + \frac{5}{4} \epsilon^2 \sin 2M + \text{Higher-order terms} \quad (1-99)$$

Equations (1-84) and (1-99) describe the motion of a body in an elliptic orbit in terms of the mean anomaly. These equations diverge for eccentricities greater than 0.6627 and converge rapidly for typical orbital eccentricities and hence are handy for manual calculation. They will be used for analytical expressions for noncircular orbits in chapter 3. Equation (1-99) is referred to as the equation-of-the-center in some books on orbital mechanics.

The Orbit in Space

Discussion has thus far been confined to that of a plane two-dimensional orbit such as, for example, an ellipse. It can be seen that the ellipse is completely specified in its plane by four independent, fixed parameters; for instance, from equation (1-35) the conic section could be completely specified by naming the angular momentum h , the energy H , the gravity parameter $g_e r_e^2$, and the argument of perigee θ_0 .

The orbit could just as well have been defined by the following parameters: the length of the semimajor axis a , the eccentricity ϵ , the argument of perigee θ_0 , and the time of perigee passage.

In each of these instances it is found that there are three physical parameters of an ellipse plus one quantity which specifies the orientation of the ellipse in the reference plane. In addition to these, two quantities are required to specify the orientation of the plane of the orbit with respect to three-dimensional space. These quantities are usually specified as the inclination, which is the angle the plane of the orbit makes with respect to the fixed reference plane; and the longitude of the ascending node,

which marks the orientation of the line of intersection of the orbit with respect to the reference plane. There are a variety of such systems in existence, each having its advantages for certain problems. Following the main line of reasoning used here, however, the system which falls naturally out of classical mechanics will be used; namely, energy, angular momentum, gravity, and whatever geometric orientation coordinates seem most appropriate for a given problem. Orientation can be assumed to be specified by inclination and the longitude of the ascending node. Under this organization form, a coordinate system such as is shown in figure 1-6 is appropriate, where θ_0 is the argument of perigee, i is the inclination of orbit plane to plane of the ecliptic, and Ω is the longitude of the ascending node.

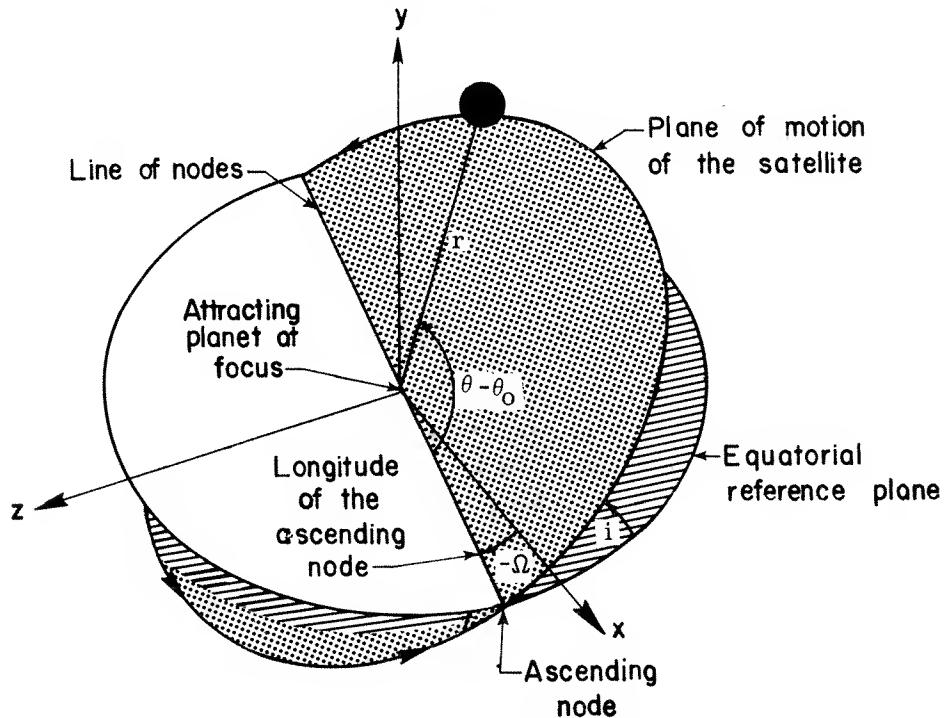

Figure 1-6.- Orbital elements in space.

Assume a rectangular coordinate system with the x -, z -axes located arbitrarily in the equatorial plane and the y -axis perpendicular to it. Then the position of the satellite at any given time is specified by

$$\left. \begin{aligned} x &= r \left[\cos(\theta - \theta_0) \cos \Omega + \sin(\theta - \theta_0) \cos i \sin \Omega \right] \\ y &= r \left[\sin(\theta - \theta_0) \sin i \right] \\ z &= r \left[\sin(\theta - \theta_0) \cos i \cos \Omega - \cos(\theta - \theta_0) \sin \Omega \right] \end{aligned} \right\} \quad (1-100)$$

where θ is the true anomaly and r is the radial distance to the satellite.

Since θ_0 , i , and Ω are all invariant for a planar orbit, it remains only to specify the relationship between r and θ to define completely the position of the satellite. This relationship can be specified by the angular momentum or the Lagrangian.

CHAPTER 2
REENTRY THEORY

CHAPTER 2

REENTRY THEORY

The objective of this chapter is to express the equations of orbital motion in a coordinate system which is natural for a reentry vehicle and to make an attempt at a solution. In so doing it will be necessary to introduce the concepts of aerodynamic lift and drag. First, however, it will be found convenient to express the orbital motion in terms of the velocity vector of an orbital vehicle. Efforts shall be confined to motion in the orbital plane, keeping in mind that in actual practice out-of-plane motion can be obtained either by thrusting out of plane or, in the atmosphere, by rolling the entry vehicle so as to produce an out-of-plane lift component. In the orbital plane the velocity vector is specified completely by the magnitude V and an orientation angle with respect to the local horizontal called the flight-path angle γ .

It is easy to see why this formalism has been useful over the years. While in this form it is true that radial velocity and angular momentum are not uncoupled, the drag force is directed opposite to that of the velocity vector. The magnitude of this force is found to be approximately proportional to the projected surface and the dynamic pressure acting on this surface. Thus, as can be seen in the following sketch (fig. 2-1), a simple resolution of forces in the direction of motion is possible.

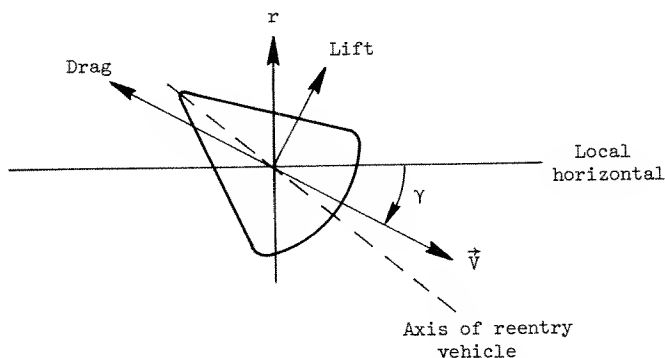

Figure 2-1.- Lift and drag forces on a reentry body.

The Lagrangian for a body in orbit about the earth in an earth-centered, inertial, polar coordinate system (z neglected) is

$$L = \frac{1}{2} m(\dot{r}^2 + r^2\dot{\theta}^2) + \frac{mg_e r_e^2}{r} \quad (2-1)$$

The equations of motion which result are

$$m\ddot{r} - mr\dot{\theta}^2 + \frac{mg_e r_e^2}{r^2} = 0 \quad (2-2)$$

$$mr^2\ddot{\theta} + 2mr\dot{r}\dot{\theta} = 0 \quad (2-3)$$

Note that equation (2-2) is a force equation while equation (2-3) is a torque equation and only becomes a force equation when divided through by r . These equations are, of course, the same as equations (1-14) and (1-15) of chapter 1.

Speed and Flight-Path Angle

Now make use of the relations which define speed and flight-path angle

$$V \cos \gamma = r \dot{\theta} \quad (2-4)$$

$$V \sin \gamma = \dot{r} \quad (2-5)$$

It follows from equations (2-4) and (2-5), by taking the time derivative,

$$r \ddot{\theta} = \dot{V} \cos \gamma - V \dot{\gamma} \sin \gamma - \dot{r} \dot{\theta} = \dot{V} \cos \gamma - V \dot{\gamma} \sin \gamma - \frac{V^2}{r} \sin \gamma \cos \gamma \quad (2-6)$$

Hence equation (2-3) becomes

$$m \dot{V} \cos \gamma - m V \dot{\gamma} \sin \gamma - m \frac{V^2}{r} \sin \gamma \cos \gamma + 2m \frac{V^2}{r} \sin \gamma \cos \gamma = 0$$

or

$$m \dot{V} \cos \gamma - m V \dot{\gamma} \sin \gamma + m \frac{V^2}{r} \sin \gamma \cos \gamma = 0 \quad (2-7)$$

Also, making use of equations (2-4) and (2-5), equation (2-2) becomes

$$m \dot{V} \sin \gamma + m V \dot{\gamma} \cos \gamma - m \frac{V^2}{r} \cos^2 \gamma + m \frac{g_e r_e^2}{r^2} = 0 \quad (2-8)$$

Now it is necessary to combine equations (2-7) and (2-8) in such a way as to separate \dot{V} and $\dot{\gamma}$:

(1) Multiply equation (2-7) by $\cos \gamma$ and equation (2-8) by $\sin \gamma$

$$m \dot{V} \cos^2 \gamma - m V \dot{\gamma} \sin \gamma \cos \gamma + m \frac{V^2}{r} \sin \gamma \cos^2 \gamma = 0 \quad (2-9)$$

$$m \dot{V} \sin^2 \gamma + m V \dot{\gamma} \sin \gamma \cos \gamma - m \frac{V^2}{r} \sin \gamma \cos^2 \gamma + m \frac{g_e r_e^2}{r^2} \sin \gamma = 0 \quad (2-10)$$

Adding equations (2-9) and (2-10) and making use of $\sin^2 \gamma + \cos^2 \gamma = 1$,

$$m \dot{V} + m \frac{g_e r_e^2}{r^2} \sin \gamma = 0 \quad (2-11)$$

(2) Multiply equation (2-7) by $\sin \gamma$ and equation (2-8) by $\cos \gamma$

$$m \dot{V} \sin \gamma \cos \gamma - m V \dot{\gamma} \sin^2 \gamma + m \frac{V^2}{r} \sin^2 \gamma \cos \gamma = 0 \quad (2-12)$$

$$m\dot{V} \sin \gamma \cos \gamma + mV\dot{\gamma} \cos^2 \gamma - m \frac{V^2}{r} \cos^3 \gamma + m \frac{g_e r_e^2}{r^2} \cos \gamma = 0 \quad (2-13)$$

Subtracting equation (2-12) from equation (2-13) and making use of $\sin^2 \gamma + \cos^2 \gamma = 1$

$$mV\dot{\gamma} - m \frac{V^2}{r} \cos \gamma + m \frac{g_e r_e^2}{r^2} \cos \gamma = 0 \quad (2-14)$$

or, since $gr^2 = g_e r_e^2$ for any r

$$mV\dot{\gamma} - mg \left(\frac{V^2}{gr} - 1 \right) \cos \gamma = 0 \quad (2-15)$$

Lift and Drag

Equations (2-11) and (2-15) represent the motion in terms of velocity and flight-path angle of a body in orbital motion (refs. 3 and 4). It should be emphasized that this is no more than an algebraic transformation and as such contains exactly the same information as equations (2-2) and (2-3). All that is done is a conversion from orthogonal velocity components to a scalar magnitude and a direction angle. Although velocity flight-path-angle coordinates may be more intuitive than the formalism of equations (2-2) and (2-3), it should also be noted that there is a penalty which must be paid. The great beauty of the classical orbital equations, equations (2-2) and (2-3), is that the angular-momentum equation is uncoupled from the energy equation, thus permitting direct integration of the equations of motion. In velocity flight-path-angle form this situation is no longer true, and no exact differential for angular momentum exists. Equations (2-11) and (2-15) are each expressions of combinations of angular momentum and energy and have to be uncoupled by essentially reversing their derivation. This fact can be seen very easily by examining the transformation equations, equations (2-4) and (2-5). It is clear that no expression equivalent to $r^2 \dot{\theta}$ is possible using just equation (2-11) or equation (2-15). Equations (2-14) and (2-15) express the reentry equations in a form which is applicable when there are no non-conservative forces present; that is, they are valid for space applications but are not valid in the atmosphere where lift and drag are present. It is thus necessary to add the nonconservative forces on the right-hand sides of these equations. The magnitude of the drag force is found to be approximately proportional to the product of the projected surface and the dynamic pressure acting on this surface. Denoting the proportionality constant by C_D , then

$$D = C_D Sq \quad (2-16)$$

where the dynamic pressure is given by

$$q = \frac{1}{2} \rho V^2 \quad (2-17)$$

and ρ is the atmospheric density. The lift force is defined analogously by

$$L = C_L Sq \quad (2-18)$$

It should be noted that C_L and C_D are both only approximately constant but this approximation is found to be good experimentally. Hence, for orbital flight in an atmosphere, equations (2-11) and (2-15) along with equations (2-4) and (2-5) form the complete set

$$m\dot{V} + mg \sin \gamma = -\frac{1}{2}\rho C_D S V^2 \quad (2-19)$$

$$mV\dot{\gamma} - mg\left(\frac{V^2}{gr} - 1\right)\cos \gamma = \frac{1}{2}\rho C_L S V^2 \quad (2-20)$$

$$r\dot{\theta} = V \cos \gamma \quad (2-4)$$

$$\dot{r} = V \sin \gamma \quad (2-5)$$

with

$$g = \frac{g_e r_e^2}{r^2} \quad (2-21)$$

to specify the local gravitational attraction at the vehicle.

The Barometric Equation

In equations such as equations (2-19) and (2-20) it is necessary to have a reasonably valid expression for the density as a function of altitude. This expression is obtained by combining the hydrostatic equation with the perfect gas law. Consider a column of gas with the density known for every given altitude as shown in figure 2-2:

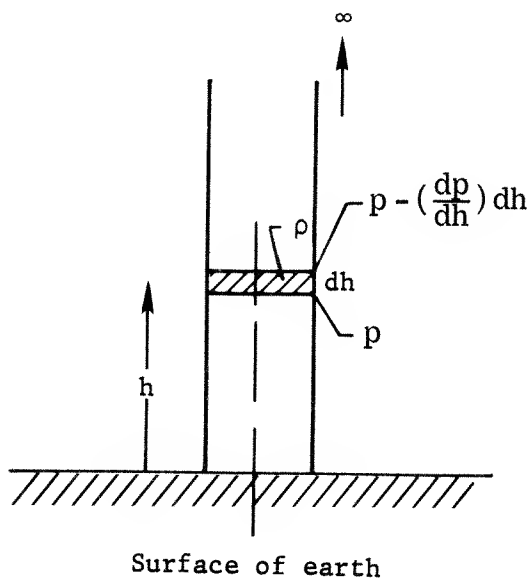

Figure 2-2.- Integration scheme to determine pressure as a function of altitude.

The hydrostatic equation is found by summing the forces acting on a small volume of gas in equilibrium. From the figure

$$p - \left(\frac{dp}{dh}\right)dh - \rho g dh = p$$

So

$$\frac{dp}{dh} = -\rho g$$

or

$$dp = -\rho g dh \quad (2-22)$$

The hydrostatic pressure p for some altitude h is given by integrating the product of pressure and density from this altitude to infinity:

$$p = \int_h^\infty \rho g dh \quad (2-23)$$

Equation (2-22) is to be combined with the perfect gas law. For any specified volume of gas which is assumed to be homogeneous and isotropic the perfect gas law gives the pressure as

$$p = \frac{kT}{M} \rho \quad (\text{Perfect gas law}) \quad (2-24)$$

where

k Boltzmann's constant, 1.380622 joules/K

T absolute temperature

M mass of air contained in unit volume

Thus, if it is assumed for any sample volume that temperature and mass are constant,

$$dp = \frac{kT}{M} d\rho \quad (2-25)$$

and equation (2-22) becomes

$$\frac{kT}{M} d\rho = -\rho g dh \quad (2-26)$$

Inserting the value of g from equation (2-21) and rearranging slightly

$$\frac{d\rho}{\rho} = -\frac{M}{kT} \frac{g_e r_e^2}{r^2} dh \quad (2-27)$$

Expressing r as

$$r = r_e + h \quad (2-28)$$

and integrating from surface $h = 0$ to some altitude h

$$\int_{\rho_e}^{\rho} \frac{d\rho}{\rho} = -\frac{M}{kT} g_e r_e^2 \int_0^h \frac{dh}{(r_e + h)^2} \quad (2-29)$$

Hence

$$\ln \frac{\rho}{\rho_e} = - \frac{M}{kT} \frac{g_e r_e^2}{(r_e + h)} \frac{h}{r_e} \quad (2-30)$$

An equation is found by solving for ρ

$$\rho = \rho_e \exp \left[- \frac{M}{kT} \frac{g_e r_e^2}{(r_e + h)} \frac{h}{r_e} \right] \quad (2-31)$$

It is usually convenient at this point to make the approximation that $r_e \approx r_e + h$ since h is small compared to r_e . Then a simpler form of the equation results

$$\rho = \rho_e e^{-\left(\frac{Mg}{kT}\right)h} \quad (2-32)$$

where

$$g \approx \frac{g_e r_e^2}{(r_e + h)r_e} \quad (2-33)$$

Since the coefficient of h in equation (2-32) is very nearly constant, it is usual practice to treat it as a constant. Setting

$$\frac{Mg}{kT} = \beta \quad (2-34)$$

the usual aerodynamic form of the equation becomes

$$\rho = \rho_e e^{-\beta h} \quad (2-35)$$

where β is frequently expressed in reciprocal terms,

$$\beta = \frac{1}{H_S} \quad (2-36)$$

The symbol H_S in this form is called the scale height and is important for planetary atmosphere studies since it is the altitude at which atmospheric density decreases to $1/e = 0.3679$ of its value at the surface. For spacecraft entry, however, β is somewhat handier. For the earth the value of β is 0.0001366/m and the scale height is approximately 7.3 km.

The usefulness of the barometric equation is not so much in the numerical results it produces as in the qualitative insight that can be gained from it in the mechanics of atmospheric entry. It can be inferred from the derivation that this equation does not yield highly accurate results, largely because the actual atmosphere is not isothermal as was assumed in the derivation. As a practical matter the equation is inaccurate by as much as a factor of two between 60 and 80 kilometers. This state of affairs is not as bad as it may seem, however, as it merely means that expected maneuvers will occur at times different from those expected and at different altitudes. Qualitatively an entry vehicle is not that sensitive to atmospheric-density variations for a large range of flight regimes.

One method of getting around this problem would be to divide the altitude of interest into layers and to determine values of β and ρ_e which accurately describe the density variation for each small layer. The analytical solution to the equations of motion to be developed in the next section, which assumes an isothermal atmosphere, could then be used to solve each problem in a stepwise fashion. The more practical solution, however, when using a large computer is to use numerical density tables from the U.S. Standard Atmosphere, and this is what is usually done.

Solution of the Atmospheric-Entry Equations

Over the years a number of closed-form solutions of equations (2-4), (2-5), (2-19), and (2-20) have been published. All have the expected drawbacks of approximate solutions to nonlinear differential equations in not being accurate enough for practical applications and in not being valid over a wide enough flight regime. These solutions have been of substantial value, however, in that they have provided a great deal of understanding of the nature of the problem. In addition, analytical solutions have been of some service in the development of guidance equations. Only two approximations are justified and they are

$$(1) \quad \sin \gamma \approx 0$$

$$(2) \quad \frac{V^2}{gr} - 1 \approx 0$$

The first approximation (ref. 4) is an expression of the fact that most entries are made at a shallow flight-path angle in order to minimize heating and maximum acceleration. While the total integrated heat at shallow flight-path angles is quite large, the maximum heat-input rate is small; hence such trajectories are the preferred ones from a heat-dissipation standpoint. The second approximation, though not necessarily limited in entry angle, is valid only wherever the velocity is equal to satellite velocity. A solution is presented here which is essentially the same as in reference 3, utilizing only the second assumption, primarily for the purpose of illustrating the general technique and for the sake of understanding. Solutions making use of assumption (1) above are abundant in the literature and none will be presented here.

The atmospheric-entry equations can be written in the form

$$\left. \begin{aligned} m\dot{V} &= -D - W \sin \gamma \\ mV\dot{\gamma} &= L + W\left(\frac{V^2}{gr} - 1\right) \cos \gamma \\ \dot{h} &= V \sin \gamma \\ r\dot{\Theta} &= V \cos \gamma \end{aligned} \right\} \quad (2-37)$$

where Θ is the down-range angle about the center of the earth and is included for the sake of completeness. A numerical integration of this set of equations for an unguided spacecraft having essentially the same physical characteristics as an Apollo spacecraft is shown in figure 2-3:

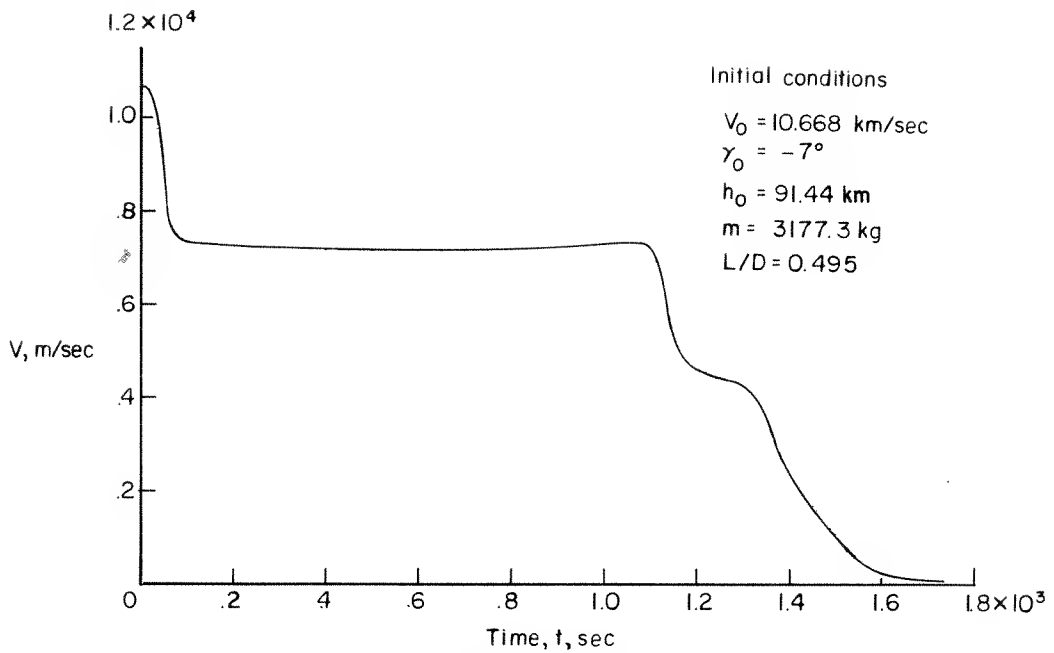

(a) Speed versus time.

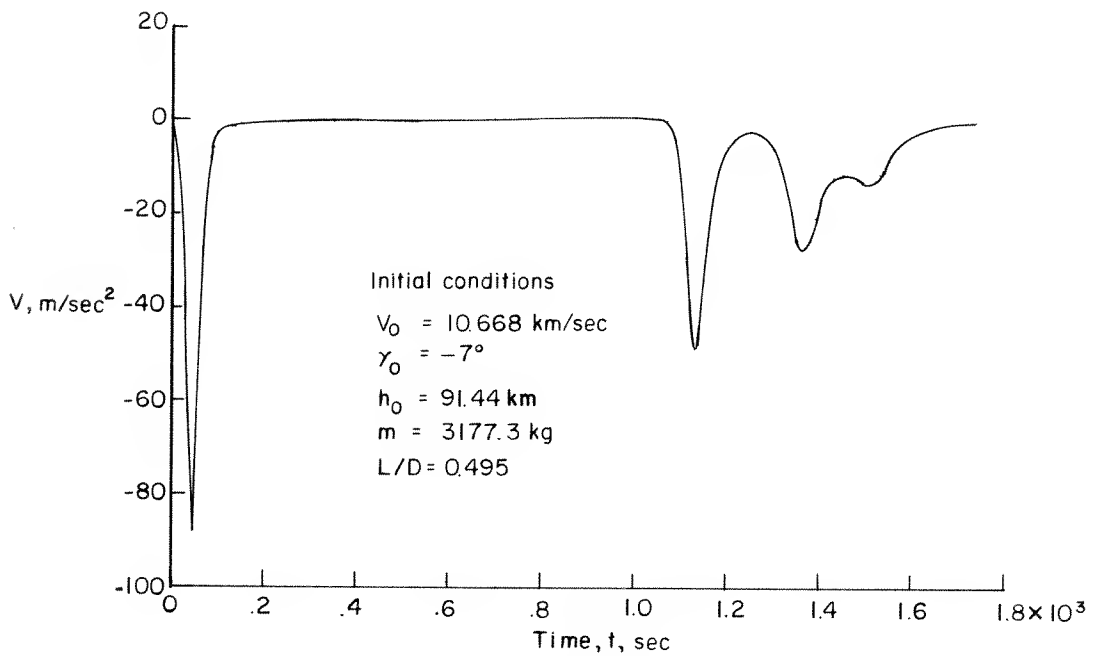

(b) Deceleration versus time.

Figure 2-3.- Unguided Apollo reentry trajectory.

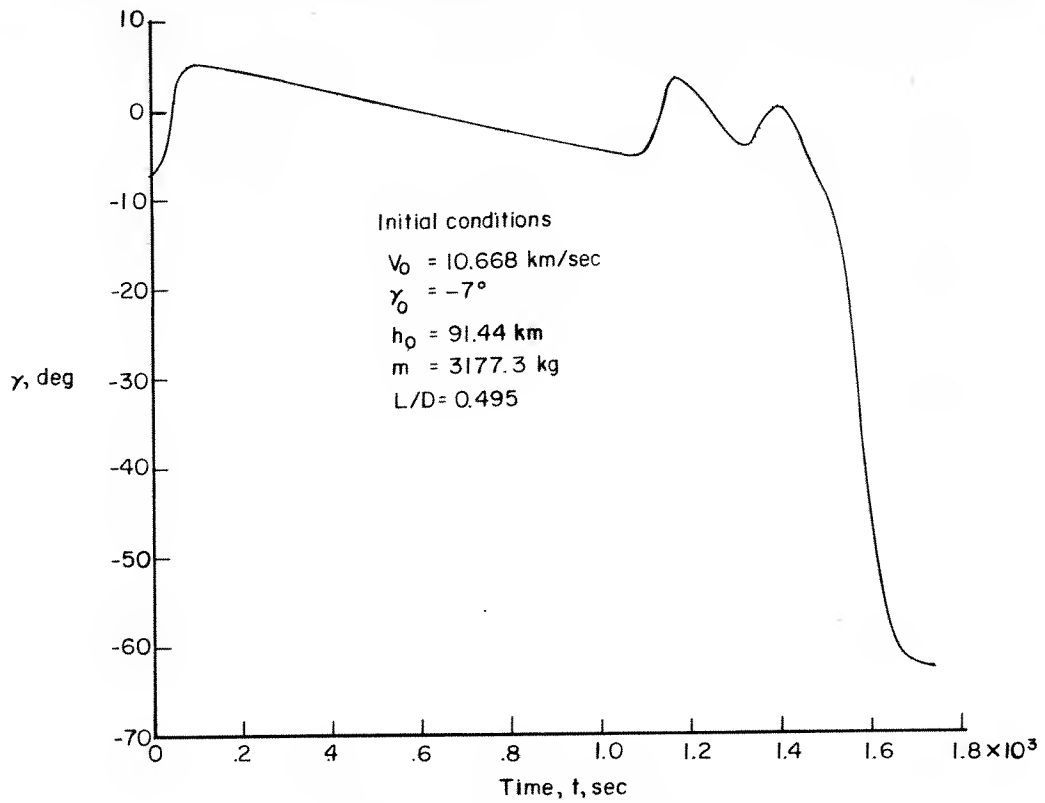

(c) Flight-path angle versus time.

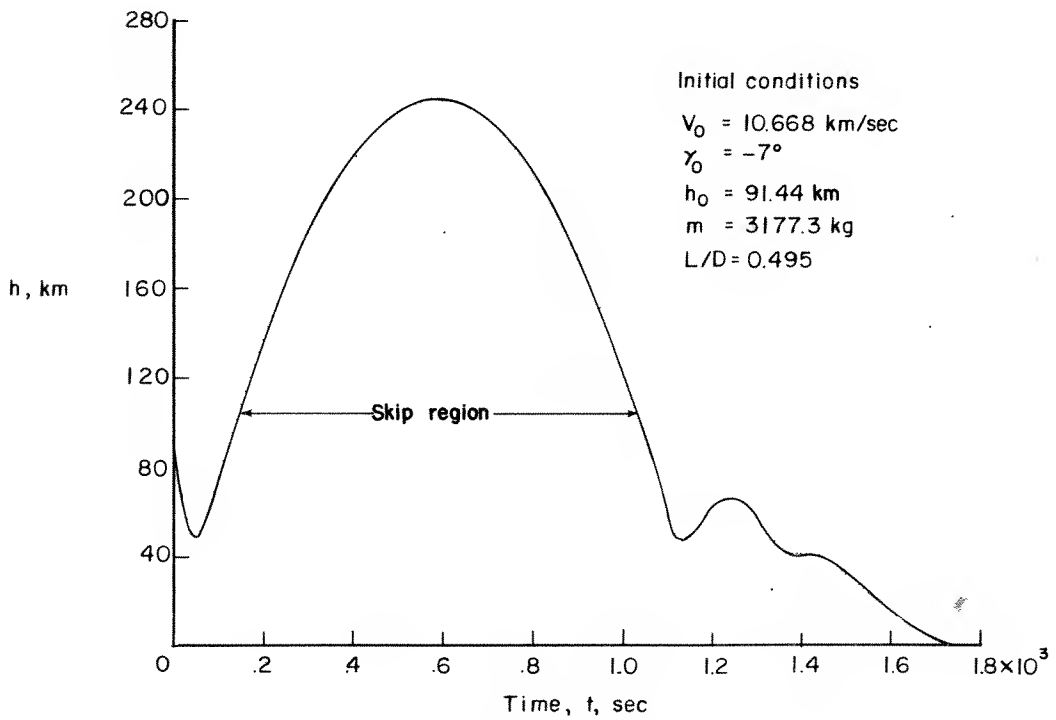

(d) Altitude versus time.

Figure 2-3.- Continued.

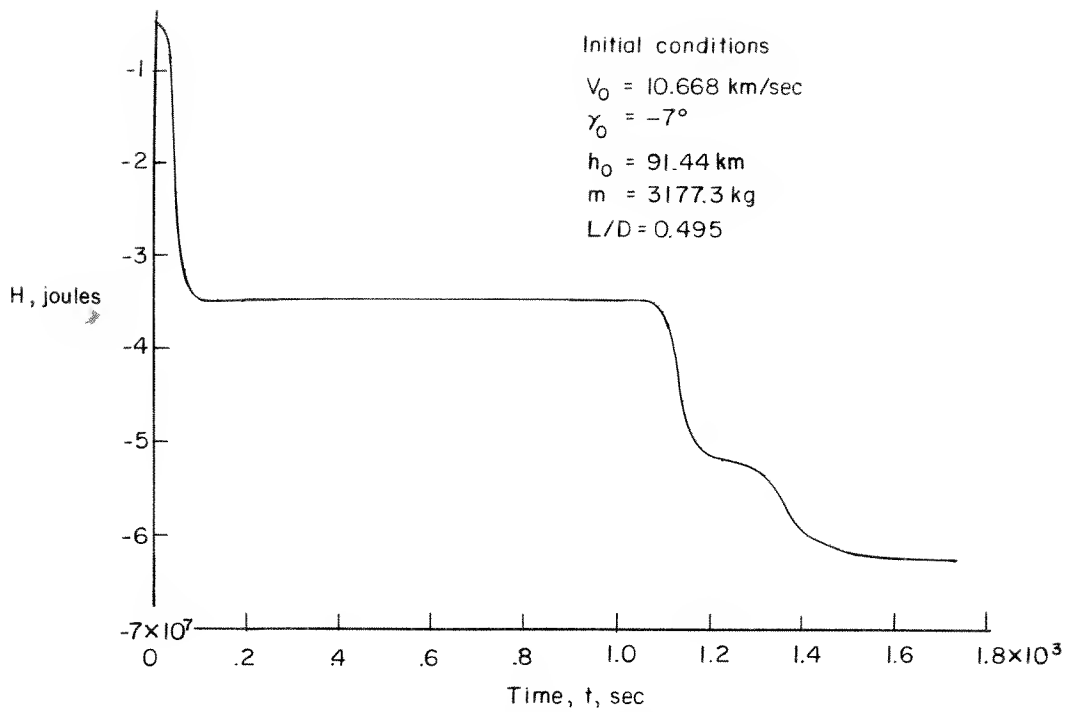

(e) Total energy versus time.

Figure 2-3.- Concluded.

For simplification of the atmospheric-entry equations, the following substitutions and assumptions are made:

Assumption (1)

The barometric equation for density applies

$$\rho = \rho_e e^{-\beta h} \quad (2-35)$$

where ρ_e and β are constants, and

$$\frac{D}{m} = K_1 e^{-\beta h} V^2$$

where $K_1 = \frac{C_D \rho_e S}{2m} = \text{Constant}$, and

$$\frac{L}{m} = K_2 e^{-\beta h} V^2$$

where $K_2 = \frac{C_L \rho_e S}{2m} = \text{Constant}$.

Assumption (2)

$$\frac{g}{V^2} \left(\frac{V^2}{gr} - 1 \right) \cos \gamma = \epsilon(V) \approx 0$$

From the second assumption it is seen that whenever the velocity is equal to satellite velocity, that is, $V = \sqrt{gr}$, or when $\gamma = 90^\circ$, the term $\epsilon(V)$ is identically zero. Hence, these closed-form solutions to the reentry equations are developed by assuming that the difference between the centrifugal and gravitational accelerations is negligible. The term $\epsilon(V)$ will be carried, however, until this assumption can be justified.

Equations developed under these assumptions apply to a number of physically useful problems; for instance, these equations would apply to most entries which are steep entries in the uppermost regions of the atmosphere. They also would be applicable to skip trajectories for satellites and spacecraft and to grazing entries by such objects as meteors and tektites.

For simplicity, the following change of the variable h to the variable y is made. Let

$$y = e^{-\beta h} \quad (2-38)$$

so that

$$\frac{\dot{y}}{y} = -\beta \dot{h} \quad (2-38a)$$

With the foregoing assumptions and the change of variables given by equations (2-38) and (2-38a), the equations of motion (2-37) become

$$\left. \begin{aligned} \dot{V} &= -K_1 y V^2 - g \sin \gamma \\ \dot{\gamma} &= K_2 y V + V \epsilon(V) \\ \dot{y} &= -\beta y V \sin \gamma \\ r \dot{\Theta} &= V \cos \gamma \end{aligned} \right\} \quad (2-39)$$

Eliminate the independent variable, time, in favor of the variable y by dividing each of the other equations through by \dot{y} . Equations (2-39) then become

$$\frac{dV}{dy} = \frac{\dot{V}}{\dot{y}} = \frac{K_1 V}{\beta \sin \gamma} + \frac{g}{\beta y V} \quad (2-40)$$

$$\frac{d\gamma}{dy} = \frac{\dot{\gamma}}{\dot{y}} = -\frac{K_2}{\beta \sin \gamma} - \frac{\epsilon(V)}{\beta y \sin \gamma} \quad (2-41)$$

and

$$\frac{d\Theta}{dy} = \frac{\dot{\Theta}}{\dot{y}} = -\frac{c \tan \gamma}{\beta r y} \quad (2-42)$$

These are the equations to be integrated for V , γ , and Θ as functions of the variable y , which in turn is expressible in terms of the altitude h . It should be noted that no assumption has been made as to the magnitude of γ ; that is, no assumption of a small flight-path angle has been made.

Variation of flight-path angle γ . - In order to evaluate the flight-path angle γ , the following steps are taken. A final, or break-out, condition is assumed at the end of the trajectory. This condition could be used to specify, for instance, the altitude of the end of the perceptible atmosphere, that is, h_b , skipping out, or the end of an entry-control mode at some height or flight-path-angle, γ_b , condition which is desired by the vehicle guidance. In any event, the subscript b represents a local, final flight condition. Then the integral of equation (2-41) becomes

$$\int_{\gamma}^{\gamma_b} \sin \gamma \, d\gamma = -\frac{K_2}{\beta} \int_y^{y_b} dy - \frac{1}{\beta} \int_y^{y_b} \frac{\epsilon(V) dy}{y}$$

If, during the interval of evaluation, $\epsilon(V)$ has a very weak variation with y , then

$$-\cos \gamma \Big|_{\gamma}^{\gamma_b} = -\frac{K_2}{\beta} y \Big|_y^{y_b} - \frac{\epsilon(V)}{\beta} \ln y \Big|_y^{y_b}$$

or

$$\cos \gamma = \cos \gamma_b + \frac{K_2}{\beta} (y - y_b) + \frac{\epsilon(V)}{\beta} \ln \frac{y}{y_b} \quad (2-43)$$

In terms of h , equation (2-43) becomes

$$\cos \gamma = \cos \gamma_b + \frac{K_2}{\beta} (e^{-\beta h} - e^{-\beta h_b}) - \epsilon(V)(h - h_b) \quad (2-44)$$

For the appropriate values of βh and βh_b

$$\frac{1}{\beta} (e^{-\beta h} - e^{-\beta h_b}) \approx -(h - h_b)$$

Since $K_2 \gg \epsilon(V)$ for most trajectories (5×10^{-7} as opposed to -1×10^{-7} as determined numerically at the point of maximum dynamic pressure and less above this point for a typical Apollo entry), it can be seen that the third term on the right-hand side of equation (2-44) can be neglected compared to the second term on the right-hand side.

Variation of the velocity V . - For purposes of evaluating velocity V as a function of y , equation (2-43) is written in the form

$$\cos \gamma = a + by \quad (2-45)$$

where

$$a = \cos \gamma_b - \frac{K_2}{\beta} y_b \quad (2-46)$$

and

$$b = \frac{K_2}{\beta} \quad (2-47)$$

Equation (2-45) may be rewritten

$$\sin \gamma = \sqrt{1 - (a + by)^2} \quad (2-48)$$

or

$$\sin \gamma = \sqrt{(1 - a^2) - 2aby - b^2y^2} \quad (2-48a)$$

Now the integral of equation (2-40) with the proper limits yields

$$\int_V^V b \frac{dV}{V} = \frac{1}{\beta} \int_y^{y_b} \left(\frac{K_1}{\sin \gamma} + \frac{g}{V^2} \right) dy \quad (2-49)$$

Again, it may be seen from numerical calculations that the second term on the right-hand side of equation (2-49) will contribute very little to the solution because $\frac{K_1}{\sin \gamma} \gg \frac{g}{V^2}$ by several orders of magnitude. Typically this number is 2.5×10^{-5} as opposed to 2.5×10^{-7} for an Apollo spacecraft at the point of maximum dynamic pressure. Furthermore, the small variations in g and V with y throughout the interval of integration will have even less influence on the solution and will therefore be neglected. Treating g and V in the second term of the right-hand side of equation (2-40) as constant average values (denoted by \bar{g} and \bar{V}) and replacing $\sin \gamma$ with the identity of equation (2-48a) alters equation (2-49) to

$$\ln \frac{V}{V_b} = -\frac{K_1}{\beta} \int_y^{y_b} \frac{dy}{\sqrt{\bar{Y}}} + \frac{\bar{g}}{\beta \bar{V}^2} \ln \frac{y}{y_b} \quad (2-50)$$

where

$$\bar{Y} = (1 - a^2) - 2aby - b^2y^2 \quad (2-50a)$$

By the use of integral tables and several trigonometric identities, the integral of the first term on the right-hand side of equation (2-50) may be put into the form

$$\int \frac{dy}{\sqrt{\bar{Y}}} = \frac{-1}{\pm b} \sin^{-1} \left(-\frac{a + by}{\pm 1} \right) \quad (2-51)$$

From equations (2-47) and (2-45),

$$\int \frac{dy}{\sqrt{\bar{Y}}} = \mp \frac{\beta}{K_2} \sin^{-1} \left(\frac{-\cos \gamma}{\pm 1} \right) = \mp \frac{\beta}{K_2} \left[\frac{\pi}{2} - \cos^{-1} \left(\frac{-\cos \gamma}{\pm 1} \right) \right] \quad (2-52)$$

Depending on the choice of signs for the second term of the right-hand side of the preceding equation, the integral of $dy/\sqrt{\bar{Y}}$ may become

$$\int \frac{dy}{\sqrt{\bar{Y}}} = \pm \frac{\beta}{K_2} \left(\frac{\pi}{2} - \gamma \right) \quad (2-52a)$$

or

$$\int \frac{dy}{\sqrt{\bar{Y}}} = \pm \frac{\beta}{K_2} \left(\frac{\pi}{2} + \gamma \right) \quad (2-52b)$$

In either case, the same answer results when the limits of equation (2-50) are applied and when the values of equations (2-52) are substituted into equation (2-50), namely,

$$\ln \frac{V}{V_b} = \pm \frac{K_1}{K_2} (\gamma - \gamma_b) + \frac{\bar{g}}{\beta \bar{V}^2} \ln \frac{y}{y_b}$$

Clearing logarithms and replacing y with $e^{\beta h}$ and K_1/K_2 with $\frac{1}{L/D}$ yields the following explicit expression for V :

$$V = V_b e^{\left[\pm \frac{D}{L} (\gamma - \gamma_b) - \frac{\bar{g}}{\bar{V}^2} (h - h_b) \right]} \quad (2-53)$$

Again it should be noted that equation (2-53) is valid only in an interval in which the second term of the exponent is always small compared to the first term. This second term should be considered an approximate second-order correction to the first term by virtue of its derivation. It also follows that, inasmuch as V_b must always be less than V (because of atmospheric drag), the first term of the exponent must always be a positive quantity. Finally, because a value of \bar{g}/\bar{V}^2 must be assigned in equation (2-50), it should suffice to use g_b and V_b if one is solving for V and to use the present-state values of g and V if one is solving for V_b . It should also be noted that this equation is not applicable for the case of zero lift although the zero-lift case can be bracketed quite nicely by applying this equation with lift values very near to zero.

Variation of range Θ . - Integration of equation (2-42) for range Θ yields the following equations:

$$\int_{\Theta}^{\Theta_b} d\Theta = -\frac{1}{\beta r} \int_{y_b}^{y_b} \frac{\text{ctn } \gamma \, dy}{y}$$

or

$$\int_{\Theta}^{\Theta_b} d\Theta = \frac{1}{\beta r} \int_{y_b}^y \frac{a + by}{\sqrt{1 - (a + by)^2}} \frac{dy}{y}$$

and

$$\int_{\Theta}^{\Theta_b} d\Theta = \frac{a}{\beta r} \int_{y_b}^y \frac{dy}{y\sqrt{Y}} + \frac{b}{\beta r} \int_{y_b}^y \frac{dy}{\sqrt{Y}}$$

At this point, three cases must be considered. First, if $a^2 = 1$, then

$$\begin{aligned} \Theta_b - \Theta &= \frac{a}{\beta r} \left(\frac{\sqrt{Y}}{aby} \right)_{y_b}^y + \frac{b}{\beta r} \left[\pm \frac{\beta}{K_2} \sin^{-1} \left(\frac{-\cos \gamma}{\pm 1} \right) \right]_{\gamma_b}^{\gamma} \\ &= \pm \frac{1}{K_2 r} \left(\frac{\sin \gamma}{y} - \frac{\sin \gamma_b}{y_b} \right) \pm \frac{1}{\beta r} (\gamma - \gamma_b) \\ &= \pm \frac{1}{K_2 r} \left(e^{\beta h} \sin \gamma - e^{\beta h_b} \sin \gamma_b \right) \pm \frac{1}{\beta r} (\gamma - \gamma_b) \end{aligned} \quad (2-54a)$$

In most practical cases a^2 is very nearly unity, therefore equation (2-54a) will usually suffice. The following possibilities are included, however, for the sake of completeness: Second, if $a^2 < 1$, then

$$\begin{aligned}
 \Theta_b - \Theta &= \pm \frac{a}{\beta r \sqrt{1-a^2}} \left[-\ln \left(\frac{\sqrt{y} + \sqrt{1-a^2}}{y} - \frac{ab}{\sqrt{1-a^2}} \right) \right]_{y_b}^y \pm \frac{1}{\beta r} (\gamma - \gamma_b) \\
 &= \pm \frac{a}{\beta r \sqrt{1-a^2}} \left[-\ln \left(\frac{\sin \gamma + \sqrt{1-a^2}}{y} - \frac{ab}{\sqrt{1-a^2}} \right) \right. \\
 &\quad \left. + \ln \left(\frac{\sin \gamma_b + \sqrt{1-a^2}}{y_b} - \frac{ab}{\sqrt{1-a^2}} \right) \right] \pm \frac{1}{\beta r} (\gamma - \gamma_b) \\
 &= \pm \frac{a}{\beta r \sqrt{1-a^2}} \left\{ \ln \left[\frac{1-a^2 - aby_b + \sqrt{1-a^2} \sin \gamma_b}{1-a^2 - aby + \sqrt{1-a^2} \sin \gamma} \left(\frac{y}{y_b} \right) \right] \right\} \pm \frac{1}{\beta r} (\gamma - \gamma_b) \\
 &= \pm \frac{a}{\beta r \sqrt{1-a^2}} \left[\ln \frac{z(y_b, \gamma_b)}{z(y, \gamma)} - \beta(h - h_b) \right] \pm \frac{1}{\beta r} (\gamma - \gamma_b) \tag{2-54b}
 \end{aligned}$$

where $z(y, \gamma) = 1 - a^2 - aby + \sqrt{1-a^2} \sin \gamma$. Third, if $a^2 > 1$, then

$$\begin{aligned}
 \Theta_b - \Theta &= \pm \frac{a}{\beta r \sqrt{a^2-1}} \left[\sin^{-1} \left(\frac{-aby + 1 - a^2}{\pm by} \right) \right]_{y_b}^y \pm \frac{1}{\beta r} (\gamma - \gamma_b) \\
 &= \pm \frac{a}{\beta r \sqrt{a^2-1}} \left[\sin^{-1} \left(\frac{1-a^2 - aby}{\pm by} \right) - \sin^{-1} \left(\frac{1-a^2 - aby_b}{\pm by_b} \right) \right] \pm \frac{1}{\beta r} (\gamma - \gamma_b) \\
 &= \pm \frac{a}{\beta r \sqrt{a^2-1}} \left\{ \sin^{-1} \left[\frac{\beta(1-a \cos \gamma)}{\pm K_2 y} \right] - \sin^{-1} \left[\frac{\beta(1-a \cos \gamma_b)}{\pm K_2 y_b} \right] \right\} \pm \frac{1}{\beta r} (\gamma - \gamma_b) \tag{2-54c}
 \end{aligned}$$

In a more compact form, equations (2-54a), (2-54b), and (2-54c) may be expressed as

$$\Theta_b - \Theta = \frac{1}{\beta r} \left[\Gamma(\gamma, h) \pm (\gamma - \gamma_b) \right] \tag{2-55}$$

where the negative sign on the term in brackets is the proper choice in all cases, and where, for the first case when $a^2 = 1$,

$$\Gamma(\gamma, h) = \pm \frac{\beta}{K_2} \left(e^{\beta h} \sin \gamma - e^{\beta h_b} \sin \gamma_b \right) \quad (2-56a)$$

for the second case when $a^2 < 1$,

$$\Gamma(\gamma, h) = \pm \frac{a}{\sqrt{1-a^2}} \left[\beta(h_b - h) + \ln \left(\frac{1 - a^2 - a b e^{-\beta h_b} + \sqrt{1-a^2} \sin \gamma_b}{1 - a^2 - a b e^{-\beta h} + \sqrt{1-a^2} \sin \gamma} \right) \right] \quad (2-56b)$$

and, finally, for $a^2 > 1$,

$$\Gamma(\gamma, h) = \pm \frac{a}{\sqrt{a^2 - 1}} \left\{ \sin^{-1} \left[\frac{\beta e^{\beta h}}{K_2} (1 - a \cos \gamma) \right] - \sin^{-1} \left[\frac{\beta e^{\beta h_b}}{K_2} (1 - a \cos \gamma_b) \right] \right\} \quad (2-56c)$$

For cases run in negative time (that is, those cases where the sign on time or else the sign on all of the velocity terms is reversed), the positive sign in the term on the right in equations (2-56b) and (2-56c) is proper. For cases run in positive time, the negative sign is proper. This sign-selection convention applies even though time does not occur explicitly in the solution in order to keep the down-range angle consistent with the flight-path angle and altitude.

Kepler Formulation of the Entry Equation Incorporating Lift and Drag

Equations (2-2) and (2-3) can be generalized from the foregoing to include the effect of lift and drag. This formulation has obvious applications in the theory of decay of near-earth satellite orbits where the drag acts as the main perturbing influence on a normally elliptic orbit. Consider figure 2-4 and resolve the lift and drag forces into their respective radial and tangential components. The radial and tangential lift and drag coefficients are given by

$$\left. \begin{aligned} C_r &= C_L \cos \gamma - C_D \sin \gamma \\ C_\theta &= -C_L \sin \gamma - C_D \cos \gamma \end{aligned} \right\} \quad (2-57)$$

Equations (2-2) and (2-3) become, in terms of forces,

$$m\ddot{r} - mr\dot{\theta}^2 + \frac{mg_e r_e^2}{r^2} = F(r) \quad (2-58)$$

$$mr\ddot{\theta} + 2m\dot{r}\dot{\theta} = F(\theta) \quad (2-59)$$

From figure 2-4

$$F(r) = L \cos \gamma - D \sin \gamma \quad (2-60)$$

$$F(\theta) = -L \sin \gamma - D \cos \gamma \quad (2-61)$$

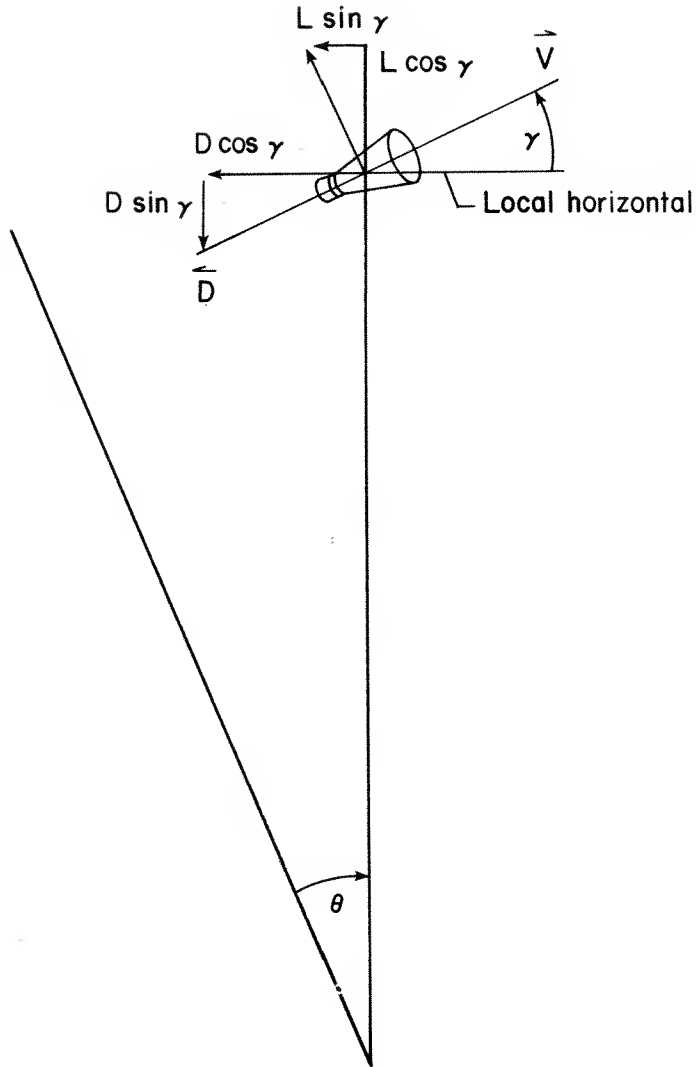

Figure 2-4.- Forces on a reentry vehicle in rectangular coordinates.

but from equations (2-4) and (2-5)

$$\cos \gamma = \frac{r\dot{\theta}}{V} \quad (2-62)$$

$$\sin \gamma = \frac{\dot{r}}{V} \quad (2-63)$$

Hence, replacing L and D with their equivalents, from equations (2-18) and (2-16), respectively,

$$F(r) = \frac{1}{2}\rho V^2 C_L S \left(\frac{r\dot{\theta}}{V} \right) - \frac{1}{2}\rho V^2 C_D S \left(\frac{\dot{r}}{V} \right) = \frac{1}{2}\rho S (r\dot{\theta} C_L - \dot{r} C_D) V \quad (2-64)$$

which, on substituting for V , becomes

$$F(r) = \frac{1}{2}\rho S (r\dot{\theta} C_L - \dot{r} C_D) (\dot{r}^2 + r^2 \dot{\theta}^2)^{1/2} \quad (2-65)$$

Also,

$$F(\theta) = -\frac{1}{2}\rho V^2 C_L S \left(\frac{\dot{r}}{V}\right) - \frac{1}{2}\rho V^2 C_D S \left(\frac{r\dot{\theta}}{V}\right) = -\frac{1}{2}\rho S (\dot{r}C_L + r\dot{\theta}C_D)V \quad (2-66)$$

which, on substituting for V , becomes

$$F(\theta) = -\frac{1}{2}\rho S (\dot{r}C_L + r\dot{\theta}C_D) (\dot{r}^2 + r^2\dot{\theta}^2)^{1/2} \quad (2-67)$$

Then equations (2-58) and (2-59) become

$$m\ddot{r} - mr\dot{\theta}^2 + \frac{mg_e r^2}{r^2} = \frac{1}{2}\rho S (r\dot{\theta}C_L - \dot{r}C_D) (\dot{r}^2 + r^2\dot{\theta}^2)^{1/2} \quad (2-68)$$

$$mr\ddot{\theta} + 2mr\dot{\theta} = -\frac{1}{2}\rho S (\dot{r}C_L + r\dot{\theta}C_D) (\dot{r}^2 + r^2\dot{\theta}^2)^{1/2} \quad (2-69)$$

These equations are formally equivalent to equations (2-19) and (2-20). It should be noted that, in spite of the familiar form shown here, these equations are coupled both in angular momentum and energy because of the lift and drag terms. Of course, these equations reduce to the usual Keplerian form if $\rho = 0$. Thus the equations of motion of a satellite with drag can be compared easily to the equations of motion of the same satellite without drag.

Energy and Momenta Rates

Although in equations (2-68) and (2-69) the total energy and the angular momentum are coupled, the same does not apply to the time derivatives of these quantities. For example, at any instant of time, the angular momentum is given by

$$mh = mr^2\dot{\theta} \quad (\text{By definition of angular momentum})$$

Then the derivative with respect to time is

$$m\dot{h} = mr^2\ddot{\theta} + 2mr\dot{r}\dot{\theta} \quad (2-70)$$

This value of $m\dot{h}$, however, is the left-hand side of equation (2-69) multiplied by r , and hence this equation can be written as

$$m\dot{h} = -\frac{1}{2}\rho S (C_D r^2\dot{\theta} + C_L r\dot{r}) (\dot{r}^2 + r^2\dot{\theta}^2)^{1/2} \quad (2-71)$$

Also, at any instant of time the total energy is

$$mH = \frac{1}{2}mV^2 - \frac{mg_e r^2}{r} \quad (\text{By definition of total energy})$$

or, taking the time derivative,

$$m\dot{H} = mV\dot{V} + \frac{mg_e r^2}{r^2} \dot{r} \quad (2-72)$$

Also, the change in energy is equal to the integrated product of the drag and the distance traveled. With s as distance and H_0 as the initial energy

$$m(H - H_0) = - \int_{s_0}^s \frac{1}{2} \rho S C_D V^2 ds \quad (2-73)$$

but

$$ds = V dt$$

so

$$m(H - H_0) = - \int_{t_0}^t \frac{1}{2} \rho S C_D V^3 dt \quad (2-74)$$

The energy rate can thus be put in the simple and elegant form

$$H = - \frac{1}{2} \frac{\rho S C_D V^3}{m} \quad (2-75)$$

This is an important conclusion in several respects: First, it is quite general; that is, there are no strained or artificial assumptions in its derivation. Second, it applies at any point along a reentry trajectory and thus depends only on the density at the present orbit. Third, although it applies to reentry equations containing lift, it does not, itself, contain any lift terms. And fourth, it is a function of the single dynamic parameter V^3 . This is as it should be. It results from the work-energy theorem of classical mechanics.

The corresponding angular momentum equation can be found in an analogous manner. By application of the transformations

$$r \dot{\theta} = V \cos \gamma$$

$$\dot{r} = V \sin \gamma$$

in equation (2-71) and cancellation of a few terms, the angular momentum is found to be

$$h = - \frac{1}{2} \frac{\rho S r V^2}{m} (C_D \cos \gamma + C_L \sin \gamma) \quad (2-76)$$

It can be seen that the rate of change of angular momentum per unit mass does depend on C_L as well as on C_D .

APPENDIX TO CHAPTER 2

DERIVATION OF EQUATIONS (2-68) AND (2-69)

The transformations developed in chapter 2 can be handled more elegantly in the following manner for those who prefer matrix techniques:

Equations (2-7) and (2-8) can be written

$$m \begin{bmatrix} \cos \gamma & -\sin \gamma \\ \sin \gamma & \cos \gamma \end{bmatrix} \begin{bmatrix} \dot{V} \\ V\dot{\gamma} \end{bmatrix} = \frac{mV^2}{r} \begin{bmatrix} -\sin \gamma \cos \gamma \\ \cos^2 \gamma \end{bmatrix} - m \begin{bmatrix} 0 \\ \frac{g_e r_e^2}{r^2} \end{bmatrix} \quad (2A-1)$$

Denote the first matrix on the left by

$$\begin{bmatrix} \cos \gamma & -\sin \gamma \\ \sin \gamma & \cos \gamma \end{bmatrix} = A \quad (2A-2)$$

Hence

$$A^{-1} = \begin{bmatrix} \cos \gamma & \sin \gamma \\ -\sin \gamma & \cos \gamma \end{bmatrix} \quad (2A-3)$$

Premultiply both sides of equation (2A-1) by A^{-1} to obtain

$$m \begin{bmatrix} \dot{V} \\ V\dot{\gamma} \end{bmatrix} = \frac{mV^2}{r} \begin{bmatrix} \cos \gamma & \sin \gamma \\ -\sin \gamma & \cos \gamma \end{bmatrix} \begin{bmatrix} -\sin \gamma \cos \gamma \\ \cos^2 \gamma \end{bmatrix} - m \begin{bmatrix} \cos \gamma & \sin \gamma \\ -\sin \gamma & \cos \gamma \end{bmatrix} \begin{bmatrix} 0 \\ \frac{g_e r_e^2}{r^2} \end{bmatrix} \quad (2A-4)$$

Thus

$$m\dot{V} = \frac{mV^2}{r} (-\sin \gamma \cos^2 \gamma + \sin \gamma \cos^2 \gamma) - \frac{mg_e r_e^2}{r^2} \sin \gamma$$

which reduces to

$$m\dot{V} + \frac{mg_e r_e^2}{r^2} \sin \gamma = 0 \quad (2-11)$$

Also,

$$mV\dot{\gamma} = \frac{mV^2}{r} (\cos \gamma \sin^2 \gamma + \cos^3 \gamma) - \frac{mg_e r_e^2}{r^2} \cos \gamma$$

which reduces to

$$mV\dot{\gamma} = \frac{mV^2}{r} \cos \gamma - \frac{mg_e r_e^2}{r^2} \cos \gamma$$

or with

$$mg = \frac{mg_e r_e^2}{r^2}$$

$$mV\dot{\gamma} - mg \left(\frac{V^2}{gr} - 1 \right) \cos \gamma = 0 \quad (2-15)$$

From equations (2-19) and (2-20),

$$m \begin{bmatrix} \dot{V} \\ V \left(\dot{\gamma} - \frac{V \cos \gamma}{r} \right) \end{bmatrix} = -mg \begin{bmatrix} \sin \gamma \\ \cos \gamma \end{bmatrix} - \frac{1}{2} \rho S V^2 \begin{bmatrix} C_D \\ -C_L \end{bmatrix} \quad (2A-5)$$

Premultiply both sides of this equation by A

$$m \begin{bmatrix} \cos \gamma & -\sin \gamma \\ \sin \gamma & \cos \gamma \end{bmatrix} \begin{bmatrix} \dot{V} \\ V \left(\dot{\gamma} - \frac{V \cos \gamma}{r} \right) \end{bmatrix} = -mg \begin{bmatrix} \cos \gamma & -\sin \gamma \\ \sin \gamma & \cos \gamma \end{bmatrix} \begin{bmatrix} \sin \gamma \\ \cos \gamma \end{bmatrix} - \frac{1}{2} \rho S V^2 \begin{bmatrix} \cos \gamma & -\sin \gamma \\ \sin \gamma & \cos \gamma \end{bmatrix} \begin{bmatrix} C_D \\ -C_L \end{bmatrix} \quad (2A-6)$$

which becomes

$$\begin{aligned}
 & m \begin{bmatrix} \dot{V} \cos \gamma - V \left(\dot{\gamma} - \frac{V \cos \gamma}{r} \right) \sin \gamma \\ \dot{V} \sin \gamma + V \left(\dot{\gamma} - \frac{V \cos \gamma}{r} \right) \cos \gamma \end{bmatrix} \\
 &= -mg \begin{bmatrix} \sin \gamma \cos \gamma - \sin \gamma \cos \gamma \\ \sin^2 \gamma + \cos^2 \gamma \end{bmatrix} - \frac{1}{2} \rho S V^2 \begin{bmatrix} C_D \cos \gamma + C_L \sin \gamma \\ C_D \sin \gamma - C_L \cos \gamma \end{bmatrix} \quad (2A-7)
 \end{aligned}$$

Equations (2-4) and (2-5) are

$$r \dot{\theta} = V \cos \gamma \quad (2-4)$$

$$\dot{r} = V \sin \gamma \quad (2-5)$$

Taking the time derivatives of these equations

$$\dot{r} \dot{\theta} + r \ddot{\theta} = \dot{V} \cos \gamma - V \sin \gamma \dot{\gamma} \quad (2A-8)$$

$$\ddot{r} = \dot{V} \sin \gamma + V \cos \gamma \dot{\gamma} \quad (2A-9)$$

Substituting these values back into equation (2A-7)

$$m \begin{bmatrix} \dot{r} \dot{\theta} + r \ddot{\theta} + \frac{V^2 \cos \gamma \sin \gamma}{r} \\ \ddot{r} - \frac{V^2 \cos^2 \gamma}{r} \end{bmatrix} = -mg \begin{bmatrix} 0 \\ 1 \end{bmatrix} - \frac{1}{2} \rho S V^2 \begin{bmatrix} C_D \cos \gamma + C_L \sin \gamma \\ C_D \sin \gamma - C_L \cos \gamma \end{bmatrix} \quad (2A-10)$$

Then, substituting various combinations of equations (2-4) and (2-5) to eliminate the remaining terms in V and γ this equation becomes

$$m \begin{bmatrix} \dot{r} \dot{\theta} + r \ddot{\theta} + \dot{r} \dot{\theta} \\ \ddot{r} - r \dot{\theta}^2 \end{bmatrix} = -mg \begin{bmatrix} 0 \\ 1 \end{bmatrix} - \frac{1}{2} \rho S \begin{bmatrix} C_D \left(\frac{r \dot{\theta}}{V} \right) + C_L \left(\frac{\dot{r}}{V} \right) \\ C_D \left(\frac{\dot{r}}{V} \right) - C_L \left(\frac{r \dot{\theta}}{V} \right) \end{bmatrix} V^2$$

APPENDIX TO CHAPTER 2 – Concluded

which is equivalent to equations (2-68) and (2-69)

$$m\ddot{r} - mr\dot{\theta}^2 + mg = \frac{1}{2}\rho S(C_L r\dot{\theta} - C_D \dot{r})\left(\dot{r}^2 + r^2\dot{\theta}^2\right)^{1/2} \quad (2-68)$$

$$mr^2\ddot{\theta} + 2mr\dot{r}\dot{\theta} = -\frac{1}{2}\rho S(C_D r^2\dot{\theta} + C_L r\dot{r})\left(\dot{r}^2 + r^2\dot{\theta}^2\right)^{1/2} \quad (2-69)$$

CHAPTER 3

RELATIVE MOTION IN RECTANGULAR COORDINATES

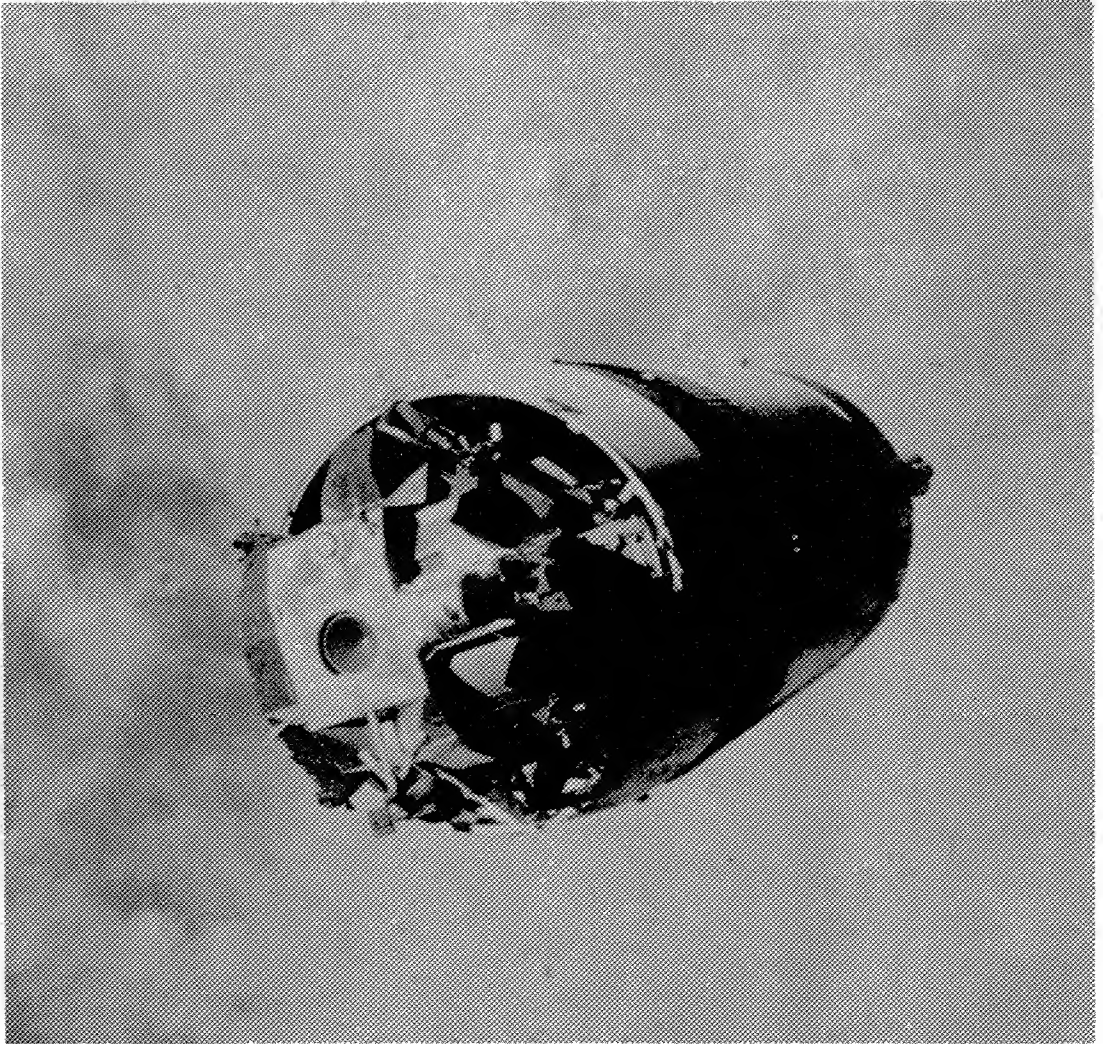

L-73-3011

The third stage of the Saturn V used to launch Apollo 9 just prior to docking for removal of the Landing Module. This photograph was taken in earth orbit.

RELATIVE MOTION IN RECTANGULAR COORDINATES

An important category of orbital motion is relative motion between two bodies which move about the same gravitationally attracting mass; for instance, it may be desired to rendezvous one spacecraft with another or with a permanent space station. Alternatively, it may be desired to keep track of a spacecraft by knowing its position at all times with respect to some simpler, better known orbit such as, for example, a circular orbit of the same period. Precise and accurate knowledge of relative distances and speeds can lead to considerable savings in terms of payload into orbit for a given size launch vehicle and, therefore, is an important cost item in modern space travel. The need for accuracy has meant that actual orbit determinations and rendezvous procedures are presently carried out numerically by means of large digital computers and ground tracking arrays. An understanding of the mechanics involved, however, that is, an understanding of how spacecraft can be expected to behave in a given situation in any given reference frame, remains an indispensable part of the design process. The purpose of this chapter is to convey an understanding of the way spacecraft appear to move when viewed from some other vantage point than the center of the earth.

In this chapter for the first time a fixed inertial reference frame is not used and instead a system is considered in which the coordinates are, themselves, in motion with respect to an inertial frame. The material in this chapter is, in fact, developed from the classical theory of moving coordinates and in every case is merely a special application of the theory. Finally, it is remarked that relative motion is the simplest and most tractable case of three-body motion, that is, three bodies, only one of which is gravitational, and the only case that can be handled adequately in a practical way without extensive numerical calculation at the present time. For purposes of this book, this is the nearest to the complicated problem of three-body motion that will be considered.

Rectangular Coordinates

Rectangular coordinates are covered first for three reasons. The first is historical, since the first rendezvous equations were presented in rectangular form. The second is pedagogical. For the beginner accustomed to thinking in rectangular coordinates, these are usually the easiest to understand. Third, rectangular coordinates are as accurate as any other system provided the bodies under consideration are in close proximity. Thus, this approach is still advantageous for some problems in rigid-body dynamics, and, in fact, rectangular coordinates will be used in the fifth chapter of this book when rigid bodies are discussed. Rectangular coordinates are not superfluous at the present point in development either, however, since shell coordinates develop rather naturally from this form. It will be seen, in fact, when the

Clohessy-Wiltshire equations are developed in this chapter in rectangular coordinates and in the next chapter in shell coordinates, that the equations are the same to first order in both systems.

The coordinate system in this approach is shown in figure 3-1. The system consists of rectangular coordinates centered on one of the bodies in orbit. In the case of rendezvous this body is usually the target vehicle.

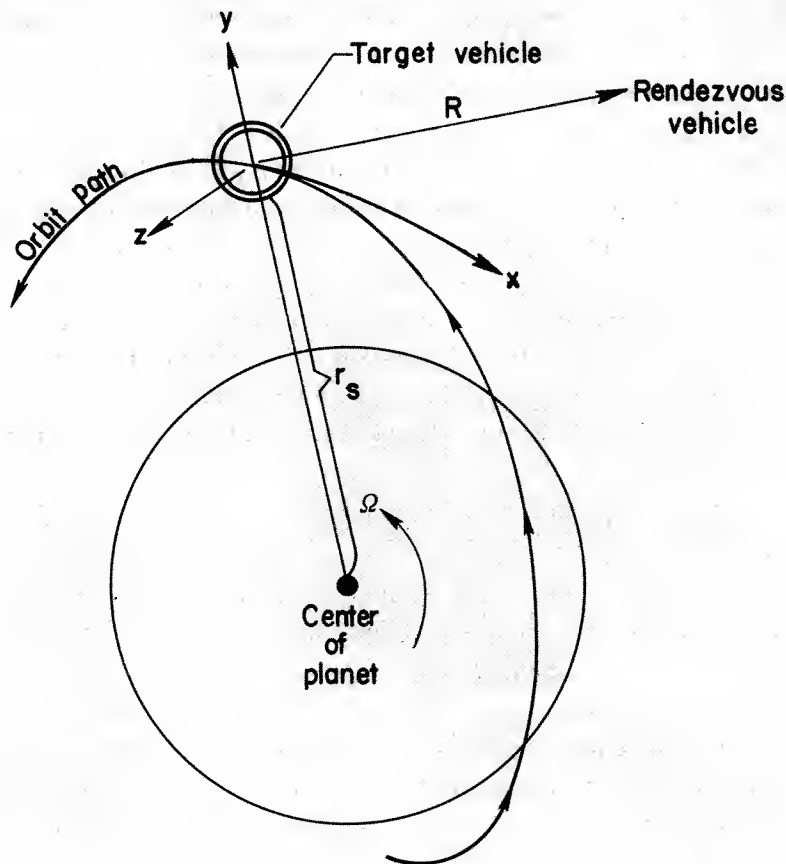

Figure 3-1.- Rectangular-coordinate system centered on a body in orbit.

In equation (1-9) we gave the general expression for the Lagrangian in a non-inertial frame of reference without translation. The equation was immediately reduced to the form of equation (1-10) by the assumption that $\vec{\Omega}$ is zero. We now go back and pick up the argument assuming that $\vec{\Omega}$ is not equal to zero. Equation (1-9) is reproduced here for the sake of convenience

$$L = \frac{1}{2} m \vec{V}^2 + m \vec{V} \cdot \vec{\Omega} \times \vec{r} + \frac{1}{2} m (\vec{\Omega} \times \vec{r})^2 - \frac{\mu}{|\vec{r}|} \quad (1-9)$$

In the case of moving coordinates (fig. 3-1) it is assumed that

$$\vec{\Omega} = \vec{k} \dot{\theta} \quad (3-1)$$

and that

$$\vec{r} = \vec{i}x + \vec{j}(y + r_s) + \vec{k}z \quad (3-2)$$

Hence, it is found that

$$\vec{\Omega} \times \vec{r} = -\vec{i}\dot{\theta}(y + r_s) + \vec{j}\dot{\theta}x \quad (3-3)$$

Also, for rectangular coordinates, the relative velocity is

$$\vec{V} = \vec{i}\dot{x} + \vec{j}(\dot{y} + \dot{r}_s) + \vec{k}\dot{z} \quad (3-4)$$

Then

$$\vec{V} \cdot \vec{\Omega} \times \vec{r} = \dot{\theta} [x(\dot{y} + \dot{r}_s) - \dot{x}(y + r_s)] \quad (3-5)$$

and

$$(\vec{\Omega} \times \vec{r})^2 = \dot{\theta}^2 [(y + r_s)^2 + x^2] \quad (3-6)$$

In rectangular coordinates $\left| \frac{\mu}{\vec{r}} \right|$ is given by

$$\left| \frac{\mu}{\vec{r}} \right| = \frac{-mg_e r_e^2}{[x^2 + (y + r_s)^2 + z^2]^{1/2}} \quad (3-7)$$

Hence, the Lagrangian becomes

$$\begin{aligned} L = & \frac{1}{2} m [\dot{x}^2 + (\dot{y} + \dot{r}_s)^2 + \dot{z}^2] + m\dot{\theta} [x(\dot{y} + \dot{r}_s) - \dot{x}(y + r_s)] \\ & + \frac{1}{2} m\dot{\theta}^2 [(y + r_s)^2 + x^2] + \frac{mg_e r_e^2}{[x^2 + (y + r_s)^2 + z^2]^{1/2}} \end{aligned} \quad (3-8)$$

Taking the appropriate derivatives, the exact differential equations of motion are arrived at in rectangular coordinates

$$m\ddot{x} - m(y + r_s)\ddot{\theta} - 2m(\dot{y} + \dot{r}_s)\dot{\theta} - m\dot{x}\dot{\theta}^2 + \frac{mg_e r_e^2 x}{[x^2 + (y + r_s)^2 + z^2]^{3/2}} = 0 \quad (3-9)$$

$$m\ddot{y} + m\dot{x}\dot{\theta} + 2m\dot{x}\dot{\theta} + m\ddot{r}_s - m(y + r_s)\dot{\theta}^2 + \frac{mg_e r_e^2 (y + r_s)}{[x^2 + (y + r_s)^2 + z^2]^{3/2}} = 0 \quad (3-10)$$

$$m\ddot{z} + \frac{mg_e r_e^2 z}{[x^2 + (y + r_s)^2 + z^2]^{3/2}} = 0 \quad (3-11)$$

If there are nonconservative forces such as thrust or drag, terms incorporating these forces may be added on the right-hand side of these equations. It will be assumed for the present, however, that there are no nonconservative forces acting on the vehicles. By factoring out the term r_s^3 in the bracket, it can be established that

$$\frac{1}{\left[x^2 + (y + r_s)^2 + z^2\right]^{3/2}} = \frac{1}{r_s^3 \left[\left(1 + \frac{y}{r_s}\right)^2 + \frac{x^2}{r_s^2} + \frac{z^2}{r_s^2}\right]^{3/2}} \quad (3-12)$$

Then, equations (3-9) through (3-11) become

$$m\ddot{x} - m(y + r_s)\ddot{\theta} - 2m(\dot{y} + \dot{r}_s)\dot{\theta} - m\dot{x}\dot{\theta}^2 + \frac{mg_e r_e^2 x}{r_s^3} \left[\left(1 + \frac{y}{r_s}\right)^2 + \frac{x^2}{r_s^2} + \frac{z^2}{r_s^2}\right]^{-3/2} = 0 \quad (3-13)$$

$$m\ddot{y} + m\dot{x}\dot{\theta} + 2m\dot{x}\dot{\theta} + m\ddot{r}_s - m(y + r_s)\dot{\theta}^2 + \frac{mg_e r_e^2 (y + r_s)}{r_s^3} \left[\left(1 + \frac{y}{r_s}\right)^2 + \frac{x^2}{r_s^2} + \frac{z^2}{r_s^2}\right]^{-3/2} = 0 \quad (3-14)$$

$$m\ddot{z} + \frac{mg_e r_e^2 z}{r_s^3} \left[\left(1 + \frac{y}{r_s}\right)^2 + \frac{x^2}{r_s^2} + \frac{z^2}{r_s^2}\right]^{-3/2} = 0 \quad (3-15)$$

This result may be specialized by assuming that the origin of the coordinate system is in circular orbit about the attracting planet. Then, denoting $\dot{\theta}$ by the constant angular rate ω and observing from equation (1-54) that

$$\frac{g_e r_e^2}{r_s^3} = \omega^2 \quad (3-16)$$

Also, if

$$\ddot{r}_s = 0$$

$$\dot{r}_s = 0$$

and also, if

$$\ddot{\theta} = 0$$

Then

$$m\ddot{x} - 2m\omega\dot{y} - m\omega^2 x + m\omega^2 x \left[\left(1 + \frac{y}{r_s}\right)^2 + \frac{x^2}{r_s^2} + \frac{z^2}{r_s^2}\right]^{-3/2} = 0 \quad (3-17)$$

$$m\ddot{y} + 2m\omega\dot{x} - m\omega^2 (y + r_s) + m\omega^2 (y + r_s) \left[\left(1 + \frac{y}{r_s}\right)^2 + \frac{x^2}{r_s^2} + \frac{z^2}{r_s^2}\right]^{-3/2} = 0 \quad (3-18)$$

$$m\ddot{z} + m\omega^2 z \left[\left(1 + \frac{y}{r_s}\right)^2 + \frac{x^2}{r_s^2} + \frac{z^2}{r_s^2} \right]^{-3/2} = 0 \quad (3-19)$$

Numerical solutions to equations (3-17) and (3-18) are presented in figure 3-2 which is modified from reference 5 for the special case where the z coordinate has been held zero. In this figure x is plotted against y for a vehicle which is ejected from the origin at various ejection angles but at a constant speed of 3 meters per second. The dashed lines show the locus of positions of the ejected vehicle for various angles of travel about the center of the earth. The effect of trajectory curvature is quite evident from the spiral nature of the resultant figure.

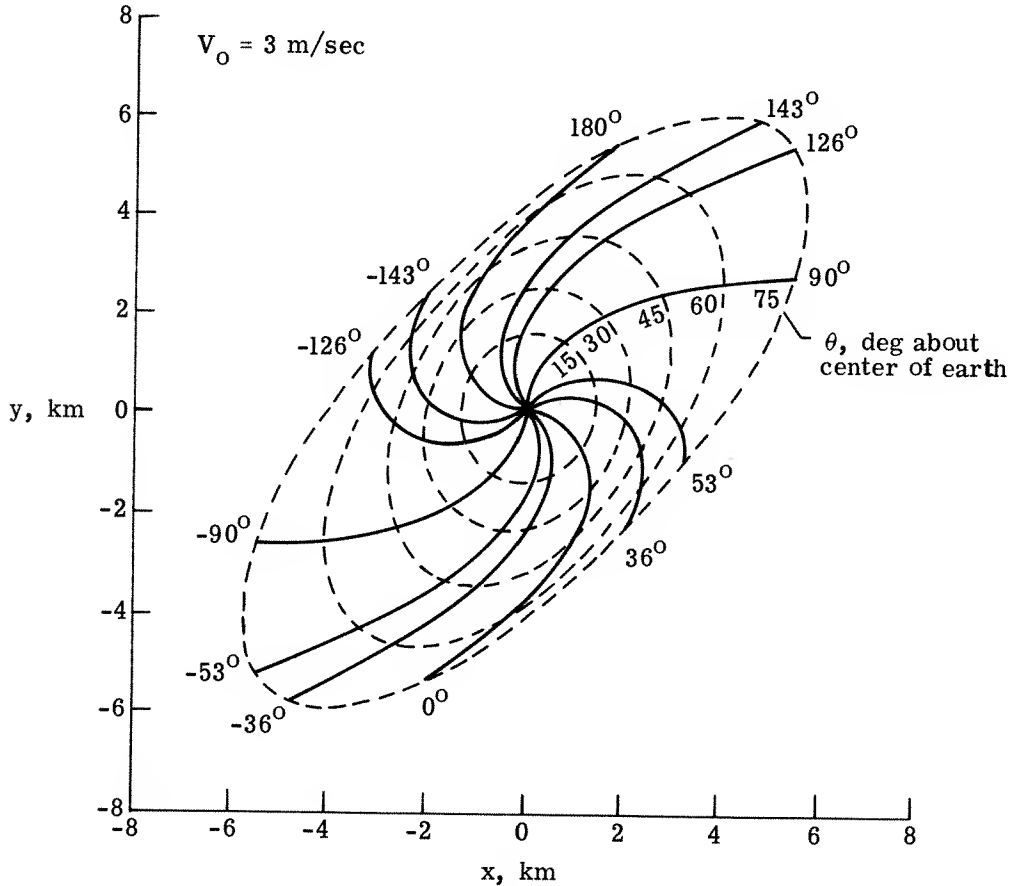

Figure 3-2.- Trajectories as measured in a coordinate system above the surface of the earth of a number of point masses (which at $t = 0$ were at the center of the coordinate system) with different initial velocity components relative to the moving coordinate system. Dashed contours denote the motion of the masses at subsequent positions of the origin of coordinates.

The last terms on the left in equations (3-17), (3-18), and (3-19) suggest that an

expansion of $\left[\left(1 + \frac{y}{r_s}\right)^2 + \left(\frac{x}{r_s}\right)^2 + \left(\frac{z}{r_s}\right)^2 \right]^{-3/2}$ in a power series might be useful in

canceling terms. Such an expansion is facilitated by the fact that under most practi-

cal circumstances x , y , and z are all much smaller than r_s so that reasonably rapid convergence can be expected. Expanding $\left(1 + \frac{y}{r_s}\right)^2$ and defining the small term ν as

$$\nu = \frac{2y}{r_s} + \left(\frac{y}{r_s}\right)^2 + \left(\frac{x}{r_s}\right)^2 + \left(\frac{z}{r_s}\right)^2 \quad (3-20)$$

The term to be expanded becomes

$$\left[\left(1 + \frac{y}{r_s}\right)^2 + \left(\frac{x}{r_s}\right)^2 + \left(\frac{z}{r_s}\right)^2 \right]^{-3/2} = (1 + \nu)^{-3/2}$$

Then, keeping three terms, an expansion of the form

$$(1 + \nu)^{-3/2} \approx 1 - \frac{3}{2} \nu + \frac{15}{8} \nu^2 + \dots$$

gives

$$\begin{aligned} \left[\left(1 + \frac{y}{r_s}\right)^2 + \left(\frac{x}{r_s}\right)^2 + \left(\frac{z}{r_s}\right)^2 \right]^{-3/2} &\approx 1 - \frac{3}{2} \left[\frac{2y}{r_s} + \left(\frac{x}{r_s}\right)^2 + \left(\frac{y}{r_s}\right)^2 + \left(\frac{z}{r_s}\right)^2 \right] \\ &+ \frac{15}{8} \left[2 \frac{y}{r_s} + \left(\frac{x}{r_s}\right)^2 + \left(\frac{y}{r_s}\right)^2 + \left(\frac{z}{r_s}\right)^2 \right]^2 + \dots \quad (3-21) \end{aligned}$$

By squaring the last term on the right and retaining terms correct to second order, equation (3-21) becomes

$$\left[\left(1 + \frac{y}{r_s}\right)^2 + \left(\frac{x}{r_s}\right)^2 + \left(\frac{z}{r_s}\right)^2 \right]^{-3/2} \approx 1 - \frac{3y}{r_s} + \frac{6y^2}{r_s^2} - \frac{3}{2} \left[\left(\frac{x}{r_s}\right)^2 + \left(\frac{z}{r_s}\right)^2 \right] \quad (3-22)$$

Making the appropriate substitutions in equations (3-17), (3-18), and (3-19) and canceling terms of higher order than the second gives

$$m\ddot{x} - 2m\omega\dot{y} - 3m\omega^2 \frac{xy}{r_s} = 0 \quad (3-23)$$

$$m\ddot{y} + 2m\omega\dot{x} - 3m\omega^2 y + 3m \frac{\omega^2 y^2}{r_s} - \frac{3}{2} m \frac{\omega^2 x^2}{r_s^2} - \frac{3}{2} m \frac{\omega^2 z^2}{r_s^2} = 0 \quad (3-24)$$

$$m\ddot{z} + m\omega^2 z - 3m\omega^2 \frac{yz}{r_s} = 0 \quad (3-25)$$

Clohessy-Wiltshire Equations

Simplification may be continued by neglecting the squared and cross-product terms since these terms are small. Then

$$m\ddot{x} - 2m\omega\dot{y} = 0 \quad (3-26)$$

$$m\ddot{y} + 2m\omega\dot{x} - 3m\omega^2 y = 0 \quad (3-27)$$

$$m\ddot{z} + m\omega^2 z = 0 \quad (3-28)$$

These, then, are the first-order relative-motion differential equations.

A first integral of equation (3-26) can be obtained directly since both terms are time derivatives. Then \dot{x} from the solution of this equation can be used in the second term of equation (3-27) to obtain a complete solution in terms of y . Finally, this solution can be applied in the first integral of equation (3-26) to solve this equation completely. Equation (3-28) is, of course, just simple harmonic motion and so can be solved directly. Thus, these three equations have the solutions:

$$x = 2\left(2\frac{\dot{x}_0}{\omega} - 3y_0\right)\sin \omega t - 2\frac{\dot{y}_0}{\omega}\cos \omega t + \left(6y_0 - 3\frac{\dot{x}_0}{\omega}\right)\omega t + 2\frac{\dot{y}_0}{\omega} + x_0 \quad (3-29)$$

$$y = \left(2\frac{\dot{x}_0}{\omega} - 3y_0\right)\cos \omega t + \frac{\dot{y}_0}{\omega}\sin \omega t + 4y_0 - 2\frac{\dot{x}_0}{\omega} \quad (3-30)$$

$$z = z_0 \cos \omega t + \frac{\dot{z}_0}{\omega} \sin \omega t \quad (3-31)$$

These equations give the position of an arbitrary vehicle relative to an origin which is itself orbiting in a circular orbit. If, for example, a target satellite is located at the origin, then x_0, y_0, z_0 and $\dot{x}_0, \dot{y}_0, \dot{z}_0$ could be interpreted as the initial position and velocity, respectively, of a rendezvous vehicle. Equations (3-29), (3-30), and (3-31) then are first-order expressions for the subsequent motion of the rendezvous vehicle with respect to the target. It follows that, if it is desired to achieve interception at some specified time τ_1 , it is merely necessary to set x , y , and z equal to zero and solve for the present velocity needed to achieve these conditions. The instantaneous relative velocity components required are given by the following expressions:

$$\frac{\dot{x}_c}{\omega} = \frac{x_0(\sin \omega\tau_1) + y_0[6\omega\tau_1 \sin \omega\tau_1 - 14(1 - \cos \omega\tau_1)]}{3\omega\tau_1 \sin \omega\tau_1 - 8(1 - \cos \omega\tau_1)} \quad (3-32)$$

$$\frac{\dot{y}_c}{\omega} = \frac{2x_0(1 - \cos \omega\tau_1) + y_0(4 \sin \omega\tau_1 - 3\omega\tau_1 \cos \omega\tau_1)}{3\omega\tau_1 \sin \omega\tau_1 - 8(1 - \cos \omega\tau_1)} \quad (3-33)$$

$$\frac{\dot{z}_c}{\omega} = \frac{-z_0}{\tan \omega\tau_1} \quad (3-34)$$

These are the rendezvous guidance equations first published by W. H. Clohessy and R. S. Wiltshire in 1960 (ref. 6). They are frequently referred to as the Clohessy-Wiltshire equations, and their influence on the development of modern analytical astrodynamics has been substantial. It should be mentioned that these equations were first used to demonstrate the technical feasibility of earth orbital rendezvous by Eggleston

and others (refs. 5 and 7). The equations were actually incorporated in the Gemini spacecraft rendezvous computer (although in shell-coordinate form) for the first successful attempts at earth orbital rendezvous. Subsequent hardware developments have tended to rely more heavily on numerical integration with digital computers due to the high accuracy attainable, but these equations are still useful for analytical and developmental work.

The great drawback of the Clohessy-Wiltshire equations, as might almost seem obvious from this derivation, is that they break down quickly. The exact differential equations describing relative motion, equations (3-9), (3-10), and (3-11), are nonlinear and cannot be solved analytically. A number of approximations were made to yield equations (3-26), (3-27), and (3-28), which are linear, and the solutions are given by equations (3-29), (3-30), and (3-31), which in turn lead to the Clohessy-Wiltshire equations, (3-32), (3-33), and (3-34). Because of the simplifications made, the Clohessy-Wiltshire equations are accurate only for relatively short time periods and for distance not too remote from the origin. The nonlinear effects, which were ignored in order to obtain analytical solutions and which, though small near the origin and for short time periods, become larger and influence the solutions more at greater distances and longer times. This loss of accuracy with distance and time can be seen in figure 3-3 where the solutions of equations (3-29) and (3-30) are compared with exact numerical solutions done on a computer.

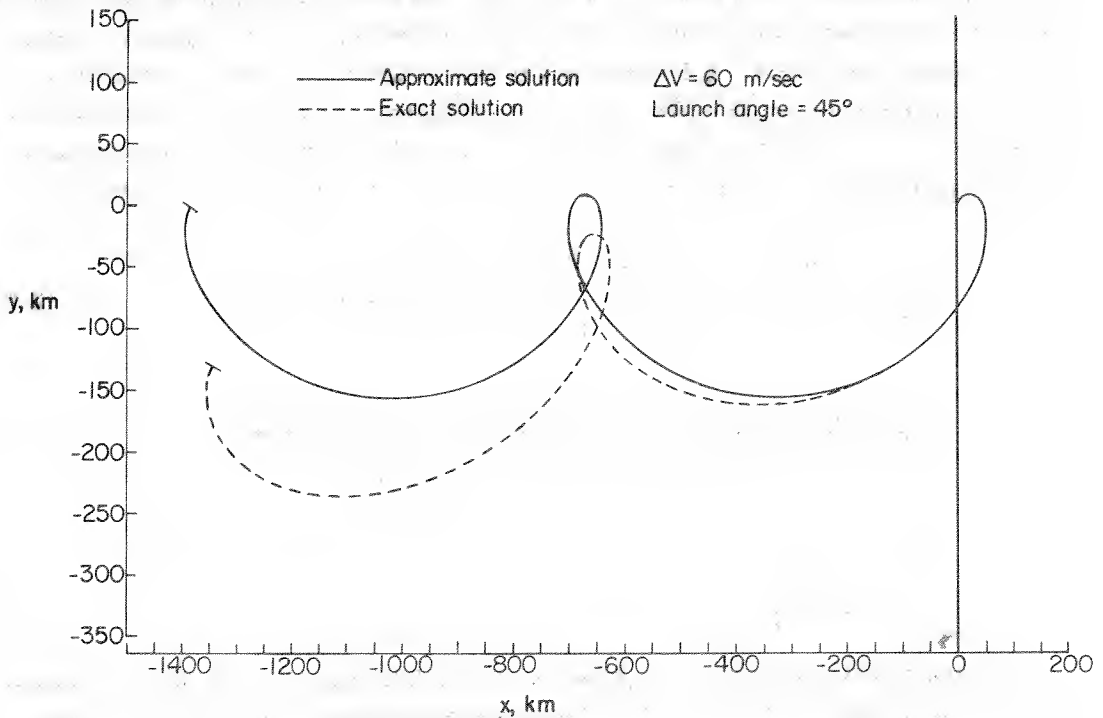

Figure 3-3.- Loss of accuracy of the first-order relative-motion equations with distance and time. This particular example is for a coordinate system in circular orbit above the earth.

Various attempts have been made to improve the accuracy of both equations (3-29), (3-30), and (3-31) and, also, (3-32), (3-33), and (3-34). In the next portion of this chapter two subsequent attempts at improving the relative motion equations (3-29), (3-30), and (3-31) will be discussed. The distinguishing feature of these two improvements is that they are in rectangular coordinates. A similar attempt in nonrectangular coordinates will be taken up in chapter 4.

London's Improvement of the Relative-Motion Equations

A second-order approximation to the solution of equations (3-17), (3-18), and (3-19) can be obtained (ref. 8) by referring back to equations (3-23), (3-24), and (3-25). Note that these equations contain terms in the gravity field expansion, equation (3-22), which were neglected in the previous linear development.

Let

$$x = x_1 + x_2$$

$$y = y_1 + y_2$$

$$z = z_1 + z_2$$

where the subscript 1 denotes the first-order solution and the subscript 2 denotes a second-order correction. Substitute these values back into equations (3-23), (3-24), and (3-25)

$$m\ddot{x}_1 + m\ddot{x}_2 - 2m\omega\dot{y}_1 - 2m\omega\dot{y}_2 - 3m\omega^2 \frac{(x_1 + x_2)(y_1 + y_2)}{r_s} = 0 \quad (3-35)$$

$$m\ddot{y}_1 + m\ddot{y}_2 + 2\omega\dot{x}_1 + 2\omega\dot{x}_2 - 3m\omega^2 y_1 - 3m\omega^2 y_2 + 3m\omega^2 \frac{(y_1 + y_2)^2}{r_s} - \frac{3}{2} m\omega^2 \frac{(x_1 + x_2)^2}{r_s^2} - \frac{3}{2} m\omega^2 \frac{(z_1 + z_2)^2}{r_s} = 0 \quad (3-36)$$

$$m\ddot{z}_1 + m\ddot{z}_2 + m\omega^2 z_1 + m\omega^2 z_2 - 3m\omega^2 \frac{(y_1 + y_2)(z_1 + z_2)}{r_s} = 0 \quad (3-37)$$

Immediately it is seen that, since x_2 , y_2 , and z_2 are to be thought of as small correction terms, higher-order terms involving x_2 , y_2 , and z_2 may be ignored. Hence, in equation (3-35)

$$- \frac{3m\omega^2}{r_s} (x_1 y_1 + x_2 y_1 + x_1 y_2 + x_2 y_2) \approx -3m\omega^2 \frac{x_1 y_1}{r_s} \quad (3-38)$$

and in equation (3-36)

$$\frac{3m\omega^2}{r_s}(y_1^2 + 2y_1y_2 + y_2^2) \approx 3m\omega^2 \frac{y_1^2}{r_s} \quad (3-39)$$

Likewise

$$-\frac{3m\omega^2}{2r_s}(x_1^2 + 2x_1x_2 + x_2^2) \approx -\frac{3}{2}m\omega^2 \frac{x_1^2}{r_s} \quad (3-40)$$

$$-\frac{3m\omega^2}{2r_s}(z_1^2 + 2z_1z_2 + z_2^2) \approx -\frac{3}{2}m\omega^2 \frac{z_1^2}{r_s} \quad (3-41)$$

Finally,

$$-\frac{3m\omega^2}{r_s}(y_1z_1 + y_2z_1 + y_1z_2 + y_2z_2) \approx -\frac{3m\omega^2}{r_s}y_1z_1 \quad (3-42)$$

Then equations (3-35), (3-36), and (3-37) become

$$m\ddot{x}_1 + m\ddot{x}_2 - 2m\omega\dot{y}_1 - 2m\omega\dot{y}_2 - 3m\omega^2 \frac{x_1y_1}{r_s} = 0 \quad (3-43)$$

$$m\ddot{y}_1 + m\ddot{y}_2 + 2m\omega\dot{x}_1 + 2m\omega\dot{x}_2 - 3m\omega^2y_1 - 3m\omega^2y_2 + 3m\omega^2 \frac{y_1^2}{r_s} - \frac{3}{2}m\omega^2 \frac{x_1^2}{r_s} - \frac{3}{2}m\omega^2 \frac{z_1^2}{r_s} = 0 \quad (3-44)$$

$$m\ddot{z}_1 + m\ddot{z}_2 + m\omega^2z_1 + m\omega^2z_2 - \frac{3m\omega^2}{r_s}y_1z_1 = 0 \quad (3-45)$$

Subtracting the first-order equations (3-26), (3-27), and (3-28) from these, respectively, yields

$$m\ddot{x}_2 - 2m\omega\dot{y}_2 = \frac{3m\omega^2}{r_s}x_1y_1 \quad (3-46)$$

$$m\ddot{y}_2 + 2m\omega\dot{x}_2 - 3m\omega^2y_2 = -\frac{3m\omega^2}{r_s}\left[y_1^2 - \frac{1}{2}(x_1^2 + z_1^2)\right] \quad (3-47)$$

$$m\ddot{z}_2 + m\omega^2z_2 = \frac{3m\omega^2}{r_s}y_1z_1 \quad (3-48)$$

Thus a set of linear differential equations with constant coefficients has been obtained for the second-order corrections. The right-hand sides are known functions of time since each term can be computed from equations (3-29), (3-30), and (3-31). It is significant that the out-of-plane and in-plane terms are now coupled. We shall find that this coupling continues when we investigate other types of coordinate systems later on.

Equation (3-46) becomes

$$\begin{aligned}
 m\ddot{x}_2 - 2m\omega\dot{y}_2 = \frac{3m\omega^2}{r_s} & \left(A_1 \cos^2 \omega t + B_1 \sin^2 \omega t + C_1 \cos \omega t \sin \omega t \right. \\
 & + D_1 \omega t \cos \omega t + E_1 \omega t \sin \omega t + F_1 \cos \omega t \\
 & \left. + G_1 \sin \omega t + I_1 \omega t + J_1 \right) \quad (3-49)
 \end{aligned}$$

where

$$A_1 = \frac{-4\dot{x}_0\dot{y}_0}{\omega^2} + \frac{6\dot{y}_0 y_0}{\omega}$$

$$B_1 = \frac{4\dot{x}_0\dot{y}_0}{\omega^2} - \frac{6y_0\dot{y}_0}{\omega}$$

$$C_1 = \frac{8\dot{x}_0^2}{\omega^2} - 24 \frac{\dot{x}_0 y_0}{\omega} + 18y_0^2 - \frac{2\dot{y}_0^2}{\omega^2}$$

$$D_1 = 21 \frac{\dot{x}_0 y_0}{\omega} - \frac{6\dot{x}_0^2}{\omega^2} - 18y_0^2$$

$$E_1 = \frac{6\dot{y}_0 y_0}{\omega} - \frac{3\dot{x}_0\dot{y}_0}{\omega^2}$$

$$F_1 = 8 \frac{\dot{x}_0\dot{y}_0}{\omega^2} - 14 \frac{\dot{y}_0 y_0}{\omega} + 2 \frac{\dot{x}_0 x_0}{\omega} - 3x_0 y_0$$

$$G_1 = 2 \frac{\dot{y}_0^2}{\omega^2} + 28 \frac{\dot{x}_0 y_0}{\omega} + \frac{x_0\dot{y}_0}{\omega} - 24y_0^2 - 8 \frac{\dot{x}_0^2}{\omega^2}$$

$$I_1 = 24y_0^2 - 24 \frac{\dot{x}_0 y_0}{\omega} + 6 \frac{\dot{x}_0^2}{\omega^2}$$

$$J_1 = -\frac{2\dot{x}_0 x_0}{\omega} + 4x_0 y_0 - 4 \frac{\dot{x}_0\dot{y}_0}{\omega^2} + 8 \frac{\dot{y}_0 y_0}{\omega}$$

Equation (3-47) becomes

$$\begin{aligned}
 m\ddot{y}_2 + 2m\omega\dot{x}_2 - 3m\omega^2 y_2 = & -\frac{3m\omega^2}{r_s} \left[A_2 \cos^2 \omega t + B_2 \sin^2 \omega t + C_2 \cos \omega t \sin \omega t \right. \\
 & + D_2 \omega t \cos \omega t + E_2 \omega t \sin \omega t + F_2 \cos \omega t \\
 & \left. + G_2 \sin \omega t + H_2 (\omega t)^2 + I_2 \omega t + J_2 \right] \quad (3-50)
 \end{aligned}$$

where

$$A_2 = \frac{4\dot{x}_0^2}{\omega^2} - 12 \frac{\dot{x}_0 y_0}{\omega} + 9y_0^2 - \frac{2\dot{y}_0^2}{\omega^2} - \frac{z_0^2}{2}$$

$$B_2 = \frac{\dot{y}_0^2}{\omega^2} - 8 \frac{\dot{x}_0^2}{\omega^2} + 24 \frac{\dot{x}_0 y_0}{\omega} - 18y_0^2 - \frac{z_0^2}{2\omega^2}$$

$$C_2 = 12 \frac{\dot{x}_0 \dot{y}_0}{\omega^2} - 18 \frac{y_0 \dot{y}_0}{\omega} - \frac{z_0 \dot{z}_0}{\omega}$$

$$D_2 = -6 \frac{\dot{x}_0 \dot{y}_0}{\omega^2} + 12 \frac{y_0 \dot{y}_0}{\omega}$$

$$E_2 = 2 \left(\frac{6\dot{x}_0^2}{\omega^2} - 21 \frac{\dot{x}_0 y_0}{\omega} + 18y_0^2 \right)$$

$$F_2 = 28 \frac{\dot{x}_0 y_0}{\omega} - 24y_0^2 - 8 \frac{\dot{x}_0^2}{\omega^2} + 4 \frac{\dot{y}_0^2}{\omega^2} + 2 \frac{x_0 \dot{y}_0}{\omega}$$

$$G_2 = -12 \frac{\dot{x}_0 \dot{y}_0}{\omega^2} - 4 \frac{x_0 \dot{x}_0}{\omega} + 20 \frac{y_0 \dot{y}_0}{\omega} + 6x_0 y_0$$

$$H_2 = -\frac{9}{2} \frac{\dot{x}_0^2}{\omega^2} + 18 \frac{\dot{x}_0 y_0}{\omega} - 18y_0^2$$

$$I_2 = 6 \frac{\dot{x}_0 \dot{y}_0}{\omega^2} + 3 \frac{x_0 \dot{x}_0}{\omega} - 12 \frac{y_0 \dot{y}_0}{\omega} - 6x_0 y_0$$

$$J_2 = 16y_0^2 - 16 \frac{\dot{x}_0 y_0}{\omega} + 4 \frac{\dot{x}_0^2}{\omega^2} - \frac{2\dot{y}_0^2}{\omega^2} - 2 \frac{x_0 \dot{y}_0}{\omega} - \frac{x_0^2}{2}$$

Equation (3-48) becomes

$$m\ddot{z}_2 + m\omega^2 z_2 = \frac{3m\omega^2}{r_s} \left(A_3 \cos^2 \omega t + B_3 \sin^2 \omega t + C_3 \cos \omega t \sin \omega t \right. \\ \left. + F_3 \cos \omega t + G_3 \sin \omega t \right) \quad (3-51)$$

where

$$A_3 = 2 \frac{\dot{x}_0 z_0}{\omega} - 3y_0 z_0$$

$$B_3 = \frac{\dot{y}_0 z_0}{\omega^2}$$

$$C_3 = 2 \frac{\dot{x}_0 \dot{z}_0}{\omega^2} - 3 \frac{y_0 \dot{z}_0}{\omega} + \frac{\dot{y}_0 z_0}{\omega}$$

$$F_3 = 4y_0 z_0 - 2 \frac{z_0 \dot{x}_0}{\omega}$$

$$G_3 = 4 \frac{y_0 \dot{z}_0}{\omega} - 2 \frac{\dot{x}_0 \dot{z}_0}{\omega^2}$$

Solutions of the form

$$x_2 = \alpha_0 + \alpha_1 \omega t + \alpha_2 \sin \omega t + \alpha_3 \cos \omega t + \alpha_4 \sin 2\omega t + \alpha_5 \cos 2\omega t \\ + \alpha_6 \omega t \sin \omega t + \alpha_7 \omega t \cos \omega t \quad (3-52)$$

$$y_2 = \beta_0 + \beta_1 \omega t + \beta_2 (\omega t)^2 + \beta_3 \sin \omega t + \beta_4 \cos \omega t + \beta_5 \sin 2\omega t \\ + \beta_6 \cos 2\omega t + \beta_7 \omega t \sin \omega t + \beta_8 \omega t \cos \omega t \quad (3-53)$$

$$z_2 = \gamma_0 + \gamma_1 \sin \omega t + \gamma_2 \cos \omega t + \gamma_3 \sin 2\omega t + \gamma_4 \cos 2\omega t \\ + \gamma_5 \omega t \sin \omega t + \gamma_6 \omega t \cos \omega t \quad (3-54)$$

are sought.

The reason for this particular form is evident from an examination of equations (3-49), (3-50), and (3-51). If these equations are converted to a multiple-angle formulation, it can be seen that compatibility upon differentiation demands just this form so that a balance of terms between the right-hand side and the left-hand side is possible with no degeneracy. The constants α_n , β_n , and γ_n are functions of the initial values x_0, y_0, z_0 and $\dot{x}_0, \dot{y}_0, \dot{z}_0$, of course. The method of solution which will be adopted here is to substitute these solutions along with the appropriate time deriva-

tives back into equations (3-49), (3-50), and (3-51) and then to compare coefficients term by term on the right-hand side. The resulting set of simultaneous equations will then yield the appropriate values of α_i , β_i , γ_i , and so forth, in terms of A_i , B_i , and C_i .

The first derivatives of equations (3-52), (3-53), and (3-54) are

$$\begin{aligned} \frac{\dot{x}_2}{\omega} &= \alpha_1 + (\alpha_2 + \alpha_7)\cos \omega t + (\alpha_6 - \alpha_3)\sin \omega t + 2\alpha_4 \cos 2\omega t \\ &\quad - 2\alpha_5 \sin 2\omega t + \alpha_6 \omega t \cos \omega t - \alpha_7 \omega t \sin \omega t \end{aligned} \quad (3-55)$$

$$\begin{aligned} \frac{\dot{y}_2}{\omega} &= \beta_1 + 2\beta_2 \omega t + (\beta_3 + \beta_8)\cos \omega t + (\beta_7 - \beta_4)\sin \omega t + 2\beta_5 \cos 2\omega t \\ &\quad - 2\beta_6 \sin 2\omega t + \beta_7 \omega t \cos \omega t - \beta_8 \omega t \sin \omega t \end{aligned} \quad (3-56)$$

$$\begin{aligned} \frac{\dot{z}_2}{\omega} &= (\gamma_1 + \gamma_6)\cos \omega t + (\gamma_5 - \gamma_2)\sin \omega t + 2\gamma_3 \cos 2\omega t - 2\gamma_4 \sin 2\omega t \\ &\quad + \gamma_5 \omega t \cos \omega t - \gamma_6 \omega t \sin \omega t \end{aligned} \quad (3-57)$$

and the second derivatives are

$$\begin{aligned} \frac{\ddot{x}_2}{\omega^2} &= -(\alpha_2 + 2\alpha_7)\sin \omega t + (2\alpha_6 - \alpha_3)\cos \omega t - 4\alpha_4 \sin 2\omega t \\ &\quad - 4\alpha_5 \cos 2\omega t - \alpha_6 \omega t \sin \omega t - \alpha_7 \omega t \cos \omega t \end{aligned} \quad (3-58)$$

$$\begin{aligned} \frac{\ddot{y}_2}{\omega^2} &= 2\beta_2 - (\beta_3 + 2\beta_8)\sin \omega t + (2\beta_7 - \beta_4)\cos \omega t - 4\beta_5 \sin 2\omega t \\ &\quad - 4\beta_6 \cos 2\omega t - \beta_7 \omega t \sin \omega t - \beta_8 \omega t \cos \omega t \end{aligned} \quad (3-59)$$

$$\begin{aligned} \frac{\ddot{z}_2}{\omega^2} &= -(\gamma_1 + 2\gamma_6)\sin \omega t + (2\gamma_5 - \gamma_2)\cos \omega t - 4\gamma_3 \sin 2\omega t \\ &\quad - 4\gamma_4 \cos 2\omega t - \gamma_5 \omega t \sin \omega t - \gamma_6 \omega t \cos \omega t \end{aligned} \quad (3-60)$$

When these substitutions are made in equations (3-49), (3-50), and (3-51) and coefficients of like terms are equated, the following sets of simultaneous equations result: From the \ddot{x} -equation

$$\frac{3}{2} \left(\frac{A_1 + B_1}{r_s} \right) + \frac{3J_1}{r_s} = -2\beta_1 \quad (3-61a)$$

$$3 \left(\frac{A_1 - B_1}{r_s} \right) = 8(\alpha_5 + \beta_5) \quad (3-61b)$$

$$\frac{3C_1}{r_s} = 8(\beta_6 - \alpha_4) \quad (3-61c)$$

$$\frac{3D_1}{r_s} = -(\alpha_7 + 2\beta_7) \quad (3-61d)$$

$$\frac{3E_1}{r_s} = 2\beta_8 - \alpha_6 \quad (3-61e)$$

$$\frac{3F_1}{r_s} = 2\alpha_6 - \alpha_3 - 2\beta_3 - 2\beta_8 \quad (3-61f)$$

$$\frac{3G_1}{r_s} = -(\alpha_2 + 2\alpha_7 + 2\beta_7 - 2\beta_4) \quad (3-61g)$$

$$\frac{3I_1}{r_s} = -4\beta_2 \quad (3-61h)$$

From the \ddot{y} -equation

$$\frac{3}{2} \left(\frac{A_2 + B_2}{r_s} \right) + \frac{3J_2}{r_s} = 3\beta_0 - 2\alpha_1 + 2\beta_2 \quad (3-62a)$$

$$\frac{3}{2} \left(\frac{A_2 - B_2}{r_s} \right) = 7\beta_6 - 4\alpha_4 - 3\beta_5 \quad (3-62b)$$

$$\frac{3C_2}{r_s} = 2(4\alpha_5 + 7\beta_5) \quad (3-62c)$$

$$\frac{3D_2}{r_s} = 2(2\beta_8 + \alpha_6) \quad (3-62d)$$

$$\frac{3E_2}{r_s} = 2(\alpha_7 + 2\beta_7) \quad (3-62e)$$

$$\frac{3F_2}{r_s} = 2(2\beta_4 - \beta_7 - \alpha_2 - \alpha_7) \quad (3-62f)$$

$$\frac{3G_2}{r_s} = 2(2\beta_3 + \beta_8 + \alpha_3 + \alpha_6) \quad (3-62g)$$

$$\frac{3H_2}{r_s} = 3\beta_2 \quad (3-62h)$$

$$\frac{3I_2}{r_s} = 3\beta_1 \quad (3-62i)$$

From the foregoing equations the independent solutions are obtained directly:

$$\alpha_4 = \frac{1}{2} \left(\frac{A_2 - B_2}{r_s} \right) - \frac{7}{8} \frac{C_1}{r_s} \quad (3-63a)$$

$$\alpha_5 = \frac{7}{8} \left(\frac{A_1 - B_1}{r_s} \right) - \frac{1}{2} \frac{C_2}{r_s} \quad (3-63b)$$

$$\alpha_6 = 3 \left(\frac{G_2}{r_s} + \frac{2F_1}{r_s} + \frac{E_1}{r_s} \right) \quad (3-63c)$$

$$\alpha_7 = 3 \left(\frac{F_2}{r_s} - \frac{1}{2} \frac{E_2}{r_s} - \frac{2G_1}{r_s} \right) \quad (3-63d)$$

$$\beta_1 = -\frac{3}{2} \frac{J_1}{r_s} = \frac{I_2}{r_s} \quad (3-63e)$$

$$\beta_2 = -\frac{3}{4} \frac{I_1}{r_s} = \frac{H_2}{r_s} \quad (3-63f)$$

$$\beta_5 = \frac{1}{2} \frac{C_2}{r_s} - \frac{1}{2} \left(\frac{A_1 - B_1}{r_s} \right) \quad (3-63g)$$

$$\beta_6 = \frac{1}{2} \left(\frac{A_2 - B_2}{r_s} \right) - \frac{1}{2} \frac{C_1}{r_s} \quad (3-63h)$$

$$\beta_7 = \frac{3}{2} \frac{E_2}{r_s} + \frac{3G_1}{r_s} - \frac{3}{2} \frac{F_2}{r_s} \quad (3-63i)$$

$$\beta_8 = \frac{3}{2} \frac{G_2}{r_s} + \frac{3F_1}{r_s} + \frac{3E_1}{r_s} \quad (3-63j)$$

In addition to the foregoing linearly independent solutions, the following linearly dependent sets of equations are obtained:

$$\left. \begin{aligned} 2\beta_3 + \alpha_3 &= \frac{3G_2}{r_s} + \frac{3F_1}{r_s} \\ 2\beta_4 - \alpha_2 &= \frac{3F_2}{r_s} - \frac{3G_1}{r_s} \end{aligned} \right\} \quad (3-64)$$

From the \ddot{z} -equation,

$$\left. \begin{aligned} \gamma_0 &= \frac{3}{2} \frac{A_3 + B_3}{r_s} \\ \gamma_3 &= -\frac{1}{2} \frac{C_3}{r_s} \\ \gamma_4 &= -\frac{1}{2} \frac{A_3 - B_3}{r_s} \\ \gamma_5 &= \frac{3}{2} \frac{F_3}{r_s} \\ \gamma_6 &= -\frac{3}{2} \frac{G_3}{r_s} \end{aligned} \right\} \quad (3-65)$$

The terms, γ_1 and γ_2 , are self-canceling due to linear dependency and hence cannot be determined at this point. To get γ_1 and γ_2 one has to apply the initial conditions that at $t = 0$, $z_2 = 0$, and $\dot{z}_2 = 0$. Then

$$\left. \begin{aligned} \gamma_1 &= -(2\gamma_3 + \gamma_6) \\ \gamma_2 &= -(\gamma_0 + \gamma_4) \end{aligned} \right\} \quad (3-66)$$

Integrating the \ddot{x} -equation, equation (3-49),

$$\begin{aligned} m\dot{x}_2 - 2m\omega y_2 &= \frac{3m\omega}{r_s} \left\{ \frac{C_1}{2} \sin^2 \omega t + \frac{A_1 - B_1}{2} \sin \omega t \cos \omega t - E_1 \omega t \cos \omega t + D_1 \omega t \sin \omega t \right. \\ &\quad \left. + (D_1 - G_1) \cos \omega t + (E_1 + F_1) \sin \omega t + \left[J_1 + \frac{1}{2}(A_1 + B_1) \right] \omega t \right. \\ &\quad \left. + \frac{I_1}{2} (\omega t)^2 + K_1 \right\} \end{aligned} \quad (3-67)$$

where K_1 is a constant of integration.

It can be seen very easily by inserting the conditions $x_2 = y_2 = 0$ at $t = 0$ that

$$D_1 - G_1 + K_1 = 0 \quad (3-68)$$

or

$$K_1 = G_1 - D_1 \quad (3-69)$$

From the integration of the \ddot{x} -equation the following simultaneous set of equations is obtained:

$$\left. \begin{aligned}
 \frac{3}{4} \frac{C_1}{r_s} &= 2(\beta_6 - \alpha_4) \\
 \frac{3}{4} \left(\frac{A_1 - B_1}{r_s} \right) &= -2(\alpha_5 + \beta_5) \\
 \frac{3E_1}{r_s} &= 2\beta_8 - \alpha_6 \\
 \frac{3D_1}{r_s} &= -2\beta_7 + \alpha_7 \\
 \frac{3(D_1 - G_1)}{r_s} &= \alpha_2 + \alpha_7 - 2\beta_4 \\
 \frac{3(E_1 + F_1)}{r_s} &= \alpha_6 - \alpha_3 - 2\beta_3 \\
 \frac{3}{2} \left(\frac{2J_1 + A_1 + B_1}{r_s} \right) &= -2\beta_1 \\
 \frac{3I_1}{2} &= -2\beta_2 \\
 \frac{3K_1}{r_s} &= \frac{3}{r_s} \left(G_1 - D_1 + \frac{C_1}{4} \right) = \alpha_1 - 2\beta_0
 \end{aligned} \right\} \quad (3-70)$$

From the last of equations (3-70) and the first identity of the \ddot{y} -equation, equation (3-62), a solvable simultaneous set is obtained, since β_2 is known already:

$$\frac{3}{2} \left(\frac{A_2 + B_2}{r_s} \right) + \frac{3J_2}{r_s} = 3\beta_0 - 2\alpha_1 - 2\beta_2 \quad (3-71)$$

$$\frac{3}{r_s} \left(G_1 - D_1 + \frac{C_1}{4} \right) = \alpha_1 - 2\beta_0 \quad (3-72)$$

Hence, replacing β_2 by H_2/r_s and eliminating α_1

$$\beta_0 = -\frac{3}{2} \left(\frac{A_2 + B_2}{r_s} \right) - \frac{3J_2}{r_s} - \frac{2H_2}{r_s} - \frac{6G_1}{r_s} + \frac{6D_1}{r_s} - \frac{3}{2} \frac{C_1}{r_s} \quad (3-73)$$

Then

$$\alpha_1 = -\frac{3}{r_s}(A_2 + B_2) - \frac{6J_2}{r_s} - \frac{4H_2}{r_s} - \frac{9}{r_s}\left(G_1 - D_1 + \frac{C_1}{4}\right) \quad (3-74)$$

Once β_0 is known, one can apply initial conditions at $t = 0$ to get, from $y_2 = 0$ at $t = 0$,

$$\beta_4 = -(\beta_0 + \beta_6) \quad (3-75)$$

Hence

$$\alpha_2 = \frac{3G_1}{r_s} - \frac{3F_2}{r_s} + 2\beta_4 \quad (3-76)$$

and from $\dot{y}_2 = 0$ at $t = 0$

$$\beta_3 = -(\beta_1 + 2\beta_5 + \beta_8) \quad (3-77)$$

Hence

$$\alpha_3 = \frac{3G_2}{r_s} + \frac{3F_1}{r_s} - 2\beta_3 \quad (3-78)$$

and, finally,

$$\alpha_0 = -(\alpha_3 + \alpha_5) \quad (3-79)$$

When these equations are solved simultaneously (which is a very tedious and time-consuming process), the resultant values are

$$\alpha_0 = 3\left(x_0 y_0 - \frac{\dot{x}_0 \dot{y}_0}{\omega^2} + \frac{5}{2} y_0 \frac{\dot{y}_0}{\omega} + \frac{1}{2} z_0 \frac{\dot{z}_0}{\omega}\right) \quad (3-80a)$$

$$\alpha_1 = 3\left(x_0^2 + \frac{11}{2} y_0^2 + \frac{1}{2} z_0^2 + \frac{2\dot{x}_0^2}{\omega^2} + \frac{1}{2} \frac{\dot{y}_0^2}{\omega^2} + \frac{1}{2} \frac{\dot{z}_0^2}{\omega^2} - 13 \frac{\dot{x}_0 \dot{y}_0}{\omega} + \frac{x_0 \dot{y}_0}{\omega}\right) \quad (3-80b)$$

$$\alpha_2 = 36 \frac{\dot{x}_0}{\omega} y_0 - 30 y_0^2 - 10 \frac{\dot{x}_0^2}{\omega^2} - 3 x_0 \frac{\dot{y}_0}{\omega} - 2 \frac{\dot{y}_0^2}{\omega^2} - 3 x_0^2 - z_0^2 - 2 \frac{\dot{z}_0^2}{\omega^2} \quad (3-80c)$$

$$\alpha_3 = -3 x_0 y_0 + \frac{2\dot{x}_0 \dot{y}_0}{\omega^2} - 6 y_0 \frac{\dot{y}_0}{\omega} - 2 z_0 \frac{\dot{z}_0}{\omega} \quad (3-80d)$$

$$\alpha_4 = \frac{1}{r_s} \left(\frac{1}{4} \frac{\dot{y}_0^2}{\omega^2} - \frac{\dot{x}_0^2}{\omega^2} + 3 \frac{\dot{x}_0}{\omega} y_0 - \frac{9}{4} y_0^2 + \frac{1}{4} \frac{\dot{z}_0^2}{\omega^2} - \frac{1}{4} z_0^2 \right) \quad (3-80e)$$

$$\alpha_5 = \frac{1}{r_s} \left[-\frac{1}{2} \frac{\dot{y}_0}{\omega} \left(3 y_0 - 2 \frac{\dot{x}_0}{\omega} \right) + \frac{1}{2} z_0 \frac{\dot{z}_0}{\omega} \right] \quad (3-80f)$$

$$\alpha_6 = -3 \frac{\dot{y}_0}{\omega} \left(2y_0 - \frac{\dot{x}_0}{\omega} \right) \quad (3-80g)$$

$$\alpha_7 = -3 \left(2y_0 - \frac{\dot{x}_0}{\omega} \right) \left(2 \frac{\dot{x}_0}{\omega} - 3y_0 \right) \quad (3-80h)$$

$$\beta_0 = 3 \left[\frac{x_0^2}{2} + \frac{\dot{x}_0^2}{\omega^2} + \frac{7}{2} y_0^2 - \frac{1}{2} \frac{\dot{y}_0^2}{\omega^2} - \frac{4\dot{x}_0}{\omega} y_0 + \frac{1}{4} \left(z_0^2 + \frac{\dot{z}_0^2}{\omega^2} \right) \right] \quad (3-81a)$$

$$\beta_1 = -\frac{3}{r_s} \left(x_0 + 2 \frac{\dot{y}_0}{\omega} \right) \left(2y_0 - \frac{\dot{x}_0}{\omega} \right) \quad (3-81b)$$

$$\beta_2 = -\frac{9}{2r_s} \left(2y_0 - \frac{\dot{x}_0}{\omega} \right)^2 \quad (3-81c)$$

$$\beta_3 = 12y_0 \frac{\dot{y}_0}{\omega} + 6x_0 y_0 - 7 \frac{\dot{x}_0 \dot{y}_0}{\omega^2} - 3x_0 \frac{\dot{x}_0}{\omega} + z_0 \frac{\dot{z}_0}{\omega} \quad (3-81d)$$

$$\beta_4 = -\frac{3}{2} x_0^2 - \frac{5\dot{x}_0^2}{\omega^2} - 15y_0^2 + \frac{2\dot{y}_0^2}{\omega^2} + \frac{18\dot{x}_0 y_0}{\omega} - \frac{\dot{z}_0^2}{\omega^2} - \frac{1}{2} z_0^2 \quad (3-81e)$$

$$\beta_5 = \frac{\dot{y}_0}{\omega} \left(\frac{2\dot{x}_0}{\omega} - 3y_0 \right) - \frac{z_0 \dot{z}_0}{2\omega} \quad (3-81f)$$

$$\beta_6 = \frac{9}{2} y_0^2 + \frac{2\dot{x}_0^2}{\omega^2} - \frac{1}{2} \frac{\dot{y}_0^2}{\omega^2} + \frac{1}{4} \frac{\dot{z}_0^2}{\omega^2} - \frac{1}{4} z_0^2 - \frac{6\dot{x}_0 y_0}{\omega} \quad (3-81g)$$

$$\beta_7 = -3 \left(\frac{2\dot{x}_0}{\omega} - 3y_0 \right) \left(2y_0 - \frac{\dot{x}_0}{\omega} \right) \quad (3-81h)$$

$$\beta_8 = 3 \frac{\dot{y}_0}{\omega} \left(2y_0 - \frac{\dot{x}_0}{\omega} \right) \quad (3-81i)$$

$$\gamma_0 = \frac{3}{2} \left[\frac{\dot{y}_0 \dot{z}_0}{\omega} + z_0 \left(2 \frac{\dot{x}_0}{\omega} - 3y_0 \right) \right] \quad (3-82a)$$

$$\gamma_1 = 3 \frac{y_0 \dot{z}_0}{\omega} - \frac{\dot{x}_0 \dot{z}_0}{\omega^2} + z_0 \frac{\dot{y}_0}{\omega} \quad (3-82b)$$

$$\gamma_2 = -2 \frac{\dot{y}_0 \dot{z}_0}{\omega^2} - 2 \frac{z_0 \dot{x}_0}{\omega} + 3y_0 z_0 \quad (3-82c)$$

$$\gamma_3 = -\frac{1}{2} \left[\frac{\dot{z}_0}{\omega} \left(2 \frac{\dot{x}_0}{\omega} - 3y_0 \right) + z_0 \frac{\dot{y}_0}{\omega} \right] \quad (3-82d)$$

$$\gamma_4 = -\frac{1}{2} \left[z_0 \left(2 \frac{\dot{x}_0}{\omega} - 3y_0 \right) - \frac{\dot{z}_0 \dot{y}_0}{\omega^2} \right] \quad (3-82e)$$

$$\gamma_5 = 3z_0 \left(2y_0 - \frac{\dot{x}_0}{\omega} \right) \quad (3-82f)$$

$$\gamma_6 = -3 \frac{\dot{z}_0}{\omega} \left(2y_0 - \frac{\dot{x}_0}{\omega} \right) \quad (3-82g)$$

The successive-approximation procedure employed here could, of course, in principle be carried to any degree of accuracy desired. It should, however, be clear from all the effort needed to extract an acceptable set of solutions to even this accuracy that the payoff is hardly worth it beyond this point. There is an advantage still to be gained, however, by assuming noncircular orbits. This procedure will be followed in the next section so that the results of these two approaches can be compared.

Analysis of Anthony and Sasaki

London's perturbation solution can be generalized (ref. 9) to include the situation where the origin of coordinates is, itself, in an elliptic orbit. The motion of the origin is approximated by means of power series in the eccentricity of the orbit. This solution is obtained in terms of the independent variable, time, by a method of differential corrections accounting for terms of second order in relative distance and first order in the orbital eccentricity of the moving origin.

As a starting point, rewrite equations (3-9), (3-10), and (3-11) in the following form, where some terms have been transposed and where the term $-mg_e r_e^2 / r_s^2$ has been subtracted from both sides of equation (3-10). Thus

$$m\ddot{x} - m\dot{y}\dot{\theta} - 2m\dot{y}\dot{\theta} - m\dot{x}\dot{\theta}^2 + \frac{mg_e r_e^2 x}{\left[x^2 + (y + r_s)^2 + z^2 \right]^{3/2}} = mr_s \ddot{\theta} + 2m\dot{r}_s \dot{\theta} \quad (3-83)$$

$$\begin{aligned} m\ddot{y} + m\dot{x}\dot{\theta} + 2m\dot{x}\dot{\theta} - m\dot{\theta}^2 y + \frac{mg_e r_e^2 (y + r_s)}{\left[x^2 + (y + r_s)^2 + z^2 \right]^{3/2}} - \frac{mg_e r_e^2}{r_s^2} \\ = -m\ddot{r}_s + mr_s \dot{\theta}^2 - \frac{mg_e r_e^2}{r_s^2} \end{aligned} \quad (3-84)$$

$$m\ddot{z} + \frac{mg_e r_e^2 z}{[x^2 + (y + r_s)^2 + z^2]^{3/2}} = 0 \quad (3-11)$$

The right-hand sides of equations (3-83) and (3-84), however, are seen to be the same as the left-hand sides of equations (2-3) and (2-2), respectively, except for sign and are thus equal to zero. Then

$$m\ddot{x} - m\dot{y}\ddot{\theta} - 2m\dot{y}\dot{\theta} - mx\dot{\theta}^2 + \frac{mg_e r_e^2 x}{[x^2 + (y + r_s)^2 + z^2]^{3/2}} = 0 \quad (3-85)$$

$$m\ddot{y} + mx\ddot{\theta} + 2m\dot{x}\dot{\theta} - m\dot{\theta}^2 y + \frac{mg_e r_e^2 (y + r_s)}{[x^2 + (y + r_s)^2 + z^2]^{3/2}} - \frac{mg_e r_e^2}{r_s^2} = 0 \quad (3-86)$$

Thus, by the use of an ingenious trick the terms in \dot{r} and \ddot{r} have been replaced by an extra potential term. Also,

$$m\ddot{z} + \frac{mg_e r_e^2 z}{[x^2 + (y + r_s)^2 + z^2]^{3/2}} = 0 \quad (3-11)$$

It is convenient to nondimensionalize in terms of the semimajor axis a by

$$\left. \begin{aligned} \tilde{X} &= \frac{x}{a} \\ \tilde{Y} &= \frac{y}{a} \\ \tilde{Z} &= \frac{z}{a} \end{aligned} \right\} \quad (3-87)$$

and

$$\rho = \frac{r_s}{a} \quad (3-88)$$

$$\tilde{\tau} = \left(\frac{r_s}{a}\right)^{3/2} \left(\frac{g_e r_e^2}{r_s^3}\right)^{1/2} t \quad (3-89)$$

or

$$\tilde{\tau} = \rho^{3/2} \omega t \quad (3-90)$$

In terms of these variables, equations (3-85), (3-86), and (3-11) become

$$\ddot{\tilde{X}} - \tilde{Y}\ddot{\theta} - 2\dot{\tilde{Y}}\dot{\theta} - \dot{\theta}^2 \tilde{X} + \frac{\tilde{X}}{[\tilde{X}^2 + (\tilde{Y} + \rho)^2 + \tilde{Z}^2]^{3/2}} = 0 \quad (3-91)$$

$$\ddot{\tilde{Y}} + \tilde{X}\ddot{\theta} + 2\dot{\tilde{X}}\dot{\theta} - \dot{\theta}^2\tilde{Y} - \frac{1}{\rho^2} + \frac{\tilde{Y} + \rho}{\left[\tilde{X}^2 + (\tilde{Y} + \rho)^2 + \tilde{Z}^2\right]^{3/2}} = 0 \quad (3-92)$$

$$\ddot{\tilde{Z}} + \frac{\tilde{Z}}{\left[\tilde{X}^2 + (\tilde{Y} + \rho)^2 + \tilde{Z}^2\right]^{3/2}} = 0 \quad (3-93)$$

where the dot over the symbol now refers to derivatives with respect to $\tilde{\tau}$. It is now assumed that the distance between the two vehicles is small compared to the semi-major axis of the vehicle at the origin of coordinates. As usual, the nonlinear terms are expanded in terms of powers of the coordinates, retaining linear and quadratic terms. When this expansion is performed,

$$\ddot{\tilde{X}} - \tilde{Y}\ddot{\theta} - 2\dot{\tilde{Y}}\dot{\theta} + \left(\frac{1}{\rho^3} - \dot{\theta}^2\right)\tilde{X} - \frac{3\tilde{X}\tilde{Y}}{\rho^4} = 0 \quad (3-94)$$

$$\ddot{\tilde{Y}} + \tilde{X}\ddot{\theta} + 2\dot{\tilde{X}}\dot{\theta} - \left(\frac{2}{\rho^3} + \dot{\theta}^2\right)\tilde{Y} - \frac{3}{2\rho^4}(\tilde{X}^2 - 2\tilde{Y}^2 + \tilde{Z}^2) = 0 \quad (3-95)$$

$$\ddot{\tilde{Z}} + \frac{\tilde{Z}}{\rho^3} - 3\frac{\tilde{Z}\tilde{Y}}{\rho^4} = 0 \quad (3-96)$$

For orbits that are nearly circular, the dependence of the angular speed and the radius to the center of coordinates upon the independent variable, time, can be taken into account by expanding $\dot{\theta}$ and r_s in terms of the eccentricity and the mean anomaly. This expansion is done by taking the time derivative of the equation-of-the-center (eq. (1-99)). If the equation is truncated at three terms on the right-hand side

$$\theta = M + 2\epsilon \sin M + \frac{5}{4}\epsilon^2 \sin 2M + \dots \quad (1-99)$$

then the ordinary time derivative is

$$\dot{\theta} = \dot{M}\left(1 + 2\epsilon \cos M + \frac{5}{2}\epsilon^2 \cos 2M + \dots\right)$$

But

$$M = \left(\frac{g_e r_e^2}{a^3}\right)^{1/2} (t - t_0)$$

so

$$\dot{M} = \left(\frac{g_e r_e^2}{a^3}\right)^{1/2}$$

Hence

$$\dot{\theta} = \left(\frac{g_e r_e^2}{r_s^3}\right)^{1/2} \left(\frac{r_s}{a}\right)^{3/2} \left(1 + 2\epsilon \cos M + \frac{5}{2}\epsilon^2 \cos 2M + \dots\right)$$

or in nondimensional form

$$\dot{\theta} = \left(1 + 2\epsilon \cos M + \frac{5}{2} \epsilon^2 \cos 2M + \dots \right) \quad (3-97)$$

where, from equation (1-67),

$$M = \frac{g_e^{1/2} r}{a^{3/2}} e (t - t_0)$$

or from equation (3-89), M is expressed in nondimensional form as,

$$M = \tilde{\tau} - \tau_0 \quad (3-98)$$

Also,

$$\rho = 1 - \epsilon \cos(\tilde{\tau} - \tau_0) + \frac{\epsilon^2}{2} \left\{ \left[1 - \cos 2(\tilde{\tau} - \tau_0) \right] + \dots \right\} \quad (3-99)$$

Solutions to equations (3-94), (3-95), and (3-96) are to be sought by assuming a first-order solution plus a small differential correction for each term. Thus, let

$$\tilde{X} = \tilde{X}_1 + \tilde{X}_2 \quad (3-100)$$

$$\tilde{Y} = \tilde{Y}_1 + \tilde{Y}_2 \quad (3-101)$$

$$\tilde{Z} = \tilde{Z}_1 + \tilde{Z}_2 \quad (3-102)$$

If the nonlinear terms are omitted and the origin is assumed to be in a nearly circular orbit, equations (3-94), (3-95), and (3-96) revert to the unintegrated form of the Clohessy-Wiltshire equations. In nondimensional notation

$$\ddot{\tilde{X}}_1 - 2\dot{\tilde{Y}}_1 = 0 \quad (3-103)$$

$$\ddot{\tilde{Y}}_1 + 2\dot{\tilde{X}}_1 - 3\tilde{Y}_1 = 0 \quad (3-104)$$

$$\ddot{\tilde{Z}}_1 + \tilde{Z}_1 = 0 \quad (3-105)$$

If, at time $\tilde{\tau} = 0$, ($t = 0$), then

$$\left. \begin{aligned} \tilde{X}_1 &= \tilde{X}_0 \\ \tilde{Y}_1 &= \tilde{Y}_0 \\ \tilde{Z}_1 &= \tilde{Z}_0 \end{aligned} \right\} \quad (3-106)$$

and

$$\left. \begin{aligned} \dot{\tilde{X}}_1 &= \dot{\tilde{X}}_0 \\ \dot{\tilde{Y}}_1 &= \dot{\tilde{Y}}_0 \\ \dot{\tilde{Z}}_1 &= \dot{\tilde{Z}}_0 \end{aligned} \right\} \quad (3-107)$$

The solutions of equations (3-103), (3-104), and (3-105) become, respectively,

$$\tilde{X}_1 = 2(\dot{\tilde{X}}_0 - 3\dot{\tilde{Y}}_0) \sin \tilde{\tau} - 2\dot{\tilde{Y}}_0 \cos \tilde{\tau} + 3(2\dot{\tilde{Y}}_0 - \dot{\tilde{X}}_0) \tilde{\tau} + (\tilde{X}_0 + 2\dot{\tilde{Y}}_0) \quad (3-108)$$

$$\tilde{Y}_1 = \dot{\tilde{Y}}_1 \sin \tilde{\tau} + 2(\dot{\tilde{X}}_0 - 3\dot{\tilde{Y}}_0) \cos \tilde{\tau} + 2(2\dot{\tilde{Y}}_0 - \dot{\tilde{X}}_0) \quad (3-109)$$

$$\tilde{Z}_1 = \dot{\tilde{Z}}_1 \sin \tilde{\tau} + \tilde{Z}_0 \cos \tilde{\tau} \quad (3-110)$$

It can be seen that these equations are exactly analogous to equations (3-29), (3-30), and (3-31). Substituting these solutions back into equations (3-94), (3-95), and (3-96), differential equations are obtained for \tilde{X}_2 , \tilde{Y}_2 , and \tilde{Z}_2 . These equations are simplified by retaining only the larger quantities such as quadratic terms in the coordinates $\tilde{X}_1^2, \tilde{Y}_1^2, \tilde{Z}_1^2$, etc., and the linear terms in the eccentricity $\epsilon \tilde{X}_1, \epsilon \tilde{Y}_1, \epsilon \tilde{Z}_1$, etc., and neglecting the smaller terms. The resulting differential equations are

$$\ddot{\tilde{X}}_2 - 2\dot{\tilde{Y}}_2 = 3\tilde{X}_1\dot{\tilde{Y}}_1 + \epsilon \left[(4\dot{\tilde{Y}}_1 + \tilde{X}_1) \cos(\tilde{\tau} - \tilde{\tau}_0) - 2\tilde{Y}_1 \sin(\tilde{\tau} - \tilde{\tau}_0) \right] \quad (3-111)$$

$$\begin{aligned} \ddot{\tilde{Y}}_2 + 2\dot{\tilde{X}}_2 - 3\tilde{Y}_2 &= \frac{3}{2}(\tilde{X}_1^2 - 2\tilde{Y}_1^2 + \tilde{Z}_1^2) + \epsilon \left[(10\tilde{Y}_1 - 4\dot{\tilde{X}}_1) \cos(\tilde{\tau} - \tilde{\tau}_0) \right. \\ &\quad \left. + 2\tilde{X}_1 \sin(\tilde{\tau} - \tilde{\tau}_0) \right] \end{aligned} \quad (3-112)$$

$$\ddot{\tilde{Z}}_2 + \tilde{Z}_2 = 3\tilde{Y}_1\dot{\tilde{Z}}_1 - 3\epsilon \tilde{Z}_1 \cos(\tilde{\tau} - \tilde{\tau}_0) \quad (3-113)$$

The initial conditions for $\tilde{X}_2, \dot{\tilde{X}}_2, \tilde{Y}_2, \dot{\tilde{Y}}_2$, and $\tilde{Z}_2, \dot{\tilde{Z}}_2$ are all zero because the general initial conditions have been satisfied by \tilde{X}_1, \tilde{Y}_1 , and \tilde{Z}_1 . Since the above set of equations is a set of linear equations with constant coefficients and known forcing functions on the right-hand side, the determination of the solution is straightforward but involves considerable effort. The technique is the same as London's with, however, still more additional terms.

Anthony and Sasaki carried out their original analysis by breaking their solution into two parts, one dependent on the eccentricity of the orbit and one not dependent on the eccentricity. The result is that the part which is independent of the eccentricity is formally equivalent to London's solutions in the limiting case of zero eccentricity and that the effect of the eccentricity shows up as a second part of each constant.

The solutions to equations (3-111), (3-112), and (3-113) are, respectively,

$$\begin{aligned}\tilde{X}_2 = & (A_0^0 + \epsilon A_0^\epsilon) + (A_1^0 + \epsilon A_1^\epsilon)\tilde{\tau} + (A_2^0 + \epsilon A_2^\epsilon)\sin \tilde{\tau} + (A_3^0 + \epsilon A_3^\epsilon)\cos \tilde{\tau} \\ & + (A_4^0 + \epsilon A_4^\epsilon)\sin 2\tilde{\tau} + (A_5^0 + \epsilon A_5^\epsilon)\cos 2\tilde{\tau} + (A_6^0 + \epsilon A_6^\epsilon)\tilde{\tau} \sin \tilde{\tau} \\ & + (A_7^0 + \epsilon A_7^\epsilon)\tilde{\tau} \cos \tilde{\tau}\end{aligned}\quad (3-114)$$

$$\begin{aligned}\tilde{Y}_2 = & (B_0^0 + \epsilon B_0^\epsilon) + (B_1^0 + \epsilon B_1^\epsilon)\tilde{\tau} + (B_2^0 + \epsilon B_2^\epsilon)\tilde{\tau}^2 + (B_3^0 + \epsilon B_3^\epsilon)\sin \tilde{\tau} \\ & + (B_4^0 + \epsilon B_4^\epsilon)\cos \tilde{\tau} + (B_5^0 + \epsilon B_5^\epsilon)\sin 2\tilde{\tau} + (B_6^0 + \epsilon B_6^\epsilon)\cos 2\tilde{\tau} \\ & + (B_7^0 + \epsilon B_7^\epsilon)\tilde{\tau} \sin \tilde{\tau} + (B_8^0 + \epsilon B_8^\epsilon)\tilde{\tau} \cos \tilde{\tau}\end{aligned}\quad (3-115)$$

$$\begin{aligned}\tilde{Z}_2 = & (C_0^0 + \epsilon C_0^\epsilon) + (C_1^0 + \epsilon C_1^\epsilon)\sin \tilde{\tau} + (C_2^0 + \epsilon C_2^\epsilon)\cos \tilde{\tau} + (C_3^0 + \epsilon C_3^\epsilon)\sin 2\tilde{\tau} \\ & + (C_4^0 + \epsilon C_4^\epsilon)\cos 2\tilde{\tau} + (C_5^0 + \epsilon C_5^\epsilon)\tilde{\tau} \sin \tilde{\tau} + (C_6^0 + \epsilon C_6^\epsilon)\tilde{\tau} \cos \tilde{\tau}\end{aligned}\quad (3-116)$$

where the coefficients A_1^0 and A_1^ϵ , etc., are given by

$$A_0^0 = 3\left(\frac{5}{2}\tilde{Y}_0\dot{\tilde{Y}}_0 - \dot{\tilde{X}}_0\dot{\tilde{Y}}_0 + \tilde{X}_0\tilde{Y}_0 + \frac{1}{2}\tilde{Z}_0\dot{\tilde{Z}}_0\right)\quad (3-117a)$$

$$A_1^0 = 3\left(\tilde{X}_0^2 + \frac{11}{2}\tilde{Y}_0^2 + 2\dot{\tilde{X}}_0^2 + \frac{1}{2}\dot{\tilde{Y}}_0^2 + \frac{1}{2}\dot{\tilde{Z}}_0^2 + \frac{1}{2}\tilde{Z}_0^2 - 13\dot{\tilde{X}}_0\tilde{Y}_0 + \tilde{X}_0\dot{\tilde{Y}}_0\right)\quad (3-117b)$$

$$A_2^0 = -3\tilde{X}_0\dot{\tilde{Y}}_0 + 36\dot{\tilde{X}}_0\tilde{Y}_0 - 10\dot{\tilde{X}}_0^2 - 2\dot{\tilde{Y}}_0^2 - 30\tilde{Y}_0^2 - 3\tilde{X}_0^2 - \tilde{Z}_0^2 - 2\dot{\tilde{Z}}_0^2\quad (3-118c)$$

$$A_3^0 = -6\tilde{Y}_0\dot{\tilde{Y}}_0 + 2\dot{\tilde{X}}_0\dot{\tilde{Y}}_0 - 3\tilde{X}_0\tilde{Y}_0 - 2\tilde{Z}_0\dot{\tilde{Z}}_0\quad (3-118d)$$

$$A_4^0 = -\dot{\tilde{X}}_0^2 + \frac{1}{4}\dot{\tilde{Y}}_0^2 + 3\dot{\tilde{X}}_0\tilde{Y}_0 - \frac{9}{4}\tilde{Y}_0^2 + \frac{1}{4}\dot{\tilde{Z}}_0^2 - \frac{1}{4}\tilde{Z}_0^2\quad (3-118e)$$

$$A_5^0 = \dot{\tilde{X}}_0\dot{\tilde{Y}}_0 - \frac{3}{2}\tilde{Y}_0\dot{\tilde{Y}}_0 + \frac{1}{2}\tilde{Z}_0\dot{\tilde{Z}}_0\quad (3-118f)$$

$$A_6^0 = -6\ddot{\tilde{Y}}_0\dot{\tilde{Y}}_0 + 3\ddot{\tilde{X}}_0\dot{\tilde{Y}}_0 \quad (3-117g)$$

$$A_7^0 = -21\dot{\tilde{X}}_0\ddot{\tilde{Y}}_0 + 6\dot{\tilde{X}}_0^2 + 18\ddot{\tilde{Y}}_0^2 \quad (3-117h)$$

$$B_0^0 = \frac{21}{2}\ddot{\tilde{Y}}_0^2 - \frac{3}{2}\dot{\tilde{Y}}_0^2 + \frac{3}{2}\ddot{\tilde{X}}_0^2 + 3\dot{\tilde{X}}_0^2 - 12\dot{\tilde{X}}_0\ddot{\tilde{Y}}_0 + \frac{3}{4}\dot{\tilde{Z}}_0^2 + \frac{3}{4}\ddot{\tilde{Z}}_0^2$$

$$B_1^0 = -6\ddot{\tilde{X}}_0\ddot{\tilde{Y}}_0 + 3\ddot{\tilde{X}}_0\dot{\tilde{X}}_0 + 6\dot{\tilde{X}}_0\dot{\tilde{Y}}_0 - 12\ddot{\tilde{Y}}_0\dot{\tilde{Y}}_0$$

$$B_2^0 = -18\ddot{\tilde{Y}}_0^2 + 18\dot{\tilde{X}}_0\ddot{\tilde{Y}}_0 - \frac{9}{2}\dot{\tilde{X}}_0^2$$

$$B_3^0 = 12\ddot{\tilde{Y}}_0\dot{\tilde{Y}}_0 - 7\dot{\tilde{X}}_0\dot{\tilde{Y}}_0 - 3\ddot{\tilde{X}}_0\dot{\tilde{X}}_0 + 6\ddot{\tilde{X}}_0\ddot{\tilde{Y}}_0 + \ddot{\tilde{Z}}_0\dot{\tilde{Z}}_0$$

$$B_4^0 = 2\dot{\tilde{Y}}_0^2 + 18\dot{\tilde{X}}_0\ddot{\tilde{Y}}_0 - 5\dot{\tilde{X}}_0^2 - 15\ddot{\tilde{Y}}_0^2 - \frac{3}{2}\ddot{\tilde{X}}_0^2 - \frac{1}{2}\ddot{\tilde{Z}}_0^2 - \dot{\tilde{Z}}_0^2 \quad (3-118)$$

$$B_5^0 = 2\dot{\tilde{X}}_0\dot{\tilde{Y}}_0 - 3\ddot{\tilde{Y}}_0\dot{\tilde{Y}}_0 - \frac{1}{2}\ddot{\tilde{Z}}_0\dot{\tilde{Z}}_0$$

$$B_6^0 = -\frac{1}{2}\dot{\tilde{Y}}_0^2 + 2\dot{\tilde{X}}_0^2 - 6\dot{\tilde{X}}_0\ddot{\tilde{Y}}_0 + \frac{9}{2}\ddot{\tilde{Y}}_0^2 + \frac{1}{4}\dot{\tilde{Z}}_0^2 - \frac{1}{4}\ddot{\tilde{Z}}_0^2$$

$$B_7^0 = -21\dot{\tilde{X}}_0\ddot{\tilde{Y}}_0 + 6\dot{\tilde{X}}_0^2 + 18\ddot{\tilde{Y}}_0^2$$

$$B_8^0 = 6\ddot{\tilde{Y}}_0\dot{\tilde{Y}}_0 - 3\dot{\tilde{X}}_0\dot{\tilde{Y}}_0$$

$$C_0^0 = \frac{3}{2}(\dot{\tilde{Y}}_0\dot{\tilde{Z}}_0 + 2\dot{\tilde{X}}_0\ddot{\tilde{Z}}_0 - 3\ddot{\tilde{Y}}_0\ddot{\tilde{Z}}_0) \quad (3-119a)$$

$$C_1^0 = \dot{\tilde{Y}}_0\ddot{\tilde{Z}}_0 - \dot{\tilde{X}}_0\dot{\tilde{Z}}_0 + 3\ddot{\tilde{Y}}_0\dot{\tilde{Z}}_0 \quad (3-119b)$$

$$C_2^0 = -2\dot{\tilde{Y}}_0\dot{\tilde{Z}}_0 - 2\dot{\tilde{X}}_0\dot{\tilde{Z}}_0 + 3\tilde{Y}_0\dot{\tilde{Z}}_0 \quad (3-119c)$$

$$C_3^0 = -\frac{1}{2}(\dot{\tilde{Y}}_0\dot{\tilde{Z}}_0 + 2\dot{\tilde{X}}_0\dot{\tilde{Z}}_0 - 3\tilde{Y}_0\dot{\tilde{Z}}_0) \quad (3-119d)$$

$$C_4^0 = -\frac{1}{2}(2\dot{\tilde{X}}_0\dot{\tilde{Z}}_0 - 3\tilde{Y}_0\dot{\tilde{Z}}_0 - \dot{\tilde{Y}}_0\dot{\tilde{Z}}_0) \quad (3-119e)$$

$$C_5^0 = \frac{3}{2}(4\tilde{Y}_0\dot{\tilde{Z}}_0 - 2\dot{\tilde{X}}_0\dot{\tilde{Z}}_0) \quad (3-199f)$$

$$C_6^0 = -\frac{3}{2}(4\tilde{Y}_0\dot{\tilde{Z}}_0 - 2\dot{\tilde{X}}_0\dot{\tilde{Z}}_0) \quad (3-119g)$$

$$\left. \begin{aligned} A_0^\epsilon &= \left(-3\dot{\tilde{X}}_0 + \frac{7}{2}\dot{\tilde{Y}}_0\right)\sin\tilde{\tau}_0 + \left(\tilde{X}_0 - \frac{1}{2}\dot{\tilde{Y}}_0\right)\cos\tilde{\tau}_0 \\ A_1^\epsilon &= -\left(3\tilde{X}_0 + 3\dot{\tilde{Y}}_0\right)\sin\tilde{\tau}_0 + \left(-3\dot{\tilde{X}}_0 + 15\tilde{Y}_0\right)\cos\tilde{\tau}_0 \\ A_2^\epsilon &= 3\left(\tilde{X}_0 + 2\dot{\tilde{Y}}_0\right)\sin\tilde{\tau}_0 - 12\tilde{Y}_0\cos\tilde{\tau}_0 \\ A_3^\epsilon &= \left(6\dot{\tilde{X}}_0 - 8\tilde{Y}_0\right)\sin\tilde{\tau}_0 + \left(-\tilde{X}_0 + 2\dot{\tilde{Y}}_0\right)\cos\tilde{\tau}_0 \\ A_4^\epsilon &= -\frac{3}{2}\dot{\tilde{Y}}_0\sin\tilde{\tau}_0 + \frac{3}{2}\left(2\dot{\tilde{X}}_0 - 3\tilde{Y}_0\right)\cos\tilde{\tau}_0 \\ A_5^\epsilon &= \frac{3}{2}\left(-2\dot{\tilde{X}}_0 + 3\tilde{Y}_0\right)\sin\tilde{\tau}_0 - \frac{3}{2}\dot{\tilde{Y}}_0\cos\tilde{\tau}_0 \\ A_6^\epsilon &= -3\left(\dot{\tilde{X}}_0 - 2\tilde{Y}_0\right)\sin\tilde{\tau}_0 \\ A_7^\epsilon &= -3\left(\dot{\tilde{X}}_0 - 2\tilde{Y}_0\right)\cos\tilde{\tau}_0 \end{aligned} \right\} \quad (3-120)$$

$$\left.
\begin{aligned}
B_0^\epsilon &= -\left(2\dot{\tilde{X}}_0 + 3\dot{\tilde{Y}}_0\right)\sin \tilde{\tau}_0 + \left(-4\dot{\tilde{X}}_0 + 13\dot{\tilde{Y}}_0\right)\cos \tilde{\tau}_0 \\
B_1^\epsilon &= 0 \\
B_2^\epsilon &= 0 \\
B_3^\epsilon &= -\dot{\tilde{X}}_0 \sin \tilde{\tau}_0 - 2\dot{\tilde{Y}}_0 \cos \tilde{\tau}_0 \\
B_4^\epsilon &= 2\left(\dot{\tilde{X}}_0 + 2\dot{\tilde{Y}}_0\right)\sin \tilde{\tau}_0 + \left(2\dot{\tilde{X}}_0 - 10\dot{\tilde{Y}}_0\right)\cos \tilde{\tau}_0 \\
B_5^\epsilon &= \left(2\dot{\tilde{X}}_0 - 3\dot{\tilde{Y}}_0\right)\sin \tilde{\tau}_0 + \dot{\tilde{Y}}_0 \cos \tilde{\tau}_0 \\
B_6^\epsilon &= -\dot{\tilde{Y}}_0 \sin \tilde{\tau}_0 + \left(2\dot{\tilde{X}}_0 - 3\dot{\tilde{Y}}_0\right)\cos \tilde{\tau}_0 \\
B_7^\epsilon &= \left(3\dot{\tilde{X}}_0 - 6\dot{\tilde{Y}}_0\right)\cos \tilde{\tau}_0 \\
B_8^\epsilon &= \left(-3\dot{\tilde{X}}_0 + 6\dot{\tilde{Y}}_0\right)\sin \tilde{\tau}_0
\end{aligned}
\right\} \quad (3-121)$$

$$C_0^\epsilon = -\frac{3}{2}\dot{\tilde{Z}}_0 \sin \tilde{\tau}_0 - \frac{3}{2}\dot{\tilde{Z}}_0 \cos \tilde{\tau}_0 \quad (3-122a)$$

$$C_1^\epsilon = -\dot{\tilde{Z}}_0 \sin \tilde{\tau}_0 - \dot{\tilde{Z}}_0 \cos \tilde{\tau}_0 \quad (3-122b)$$

$$C_2^\epsilon = 2\dot{\tilde{Z}}_0 \sin \tilde{\tau}_0 + \dot{\tilde{Z}}_0 \cos \tilde{\tau}_0 \quad (3-122c)$$

$$C_3^\epsilon = \frac{1}{2}\dot{\tilde{Z}}_0 \sin \tilde{\tau}_0 + \frac{1}{2}\dot{\tilde{Z}}_0 \cos \tilde{\tau}_0 \quad (3-122d)$$

$$C_4^\epsilon = -\frac{1}{2} \dot{\tilde{Z}}_0 \sin \tilde{\tau}_0 + \frac{1}{2} \tilde{Z}_0 \cos \tilde{\tau}_0 \quad (3-122e)$$

$$C_5^\epsilon = 0 \quad (3-122f)$$

$$C_6^\epsilon = 0 \quad (3-122g)$$

It can be seen from the above two examples of perturbation solutions to relative-motion equations that the complexity of the solutions gets out of hand quite rapidly if one is to try for high accuracy. The question can then be legitimately asked: what advantage can one expect to gain from these solutions? The answer, of course, is long-term physical insight into the nature of orbits. One often wishes to ask the question: will one satellite in the near vicinity of another remain there or drift away and, if so, how fast will it drift away? Or, alternatively, where is the best location to place an experiment package in the vicinity of, say, a manned space station, so that the longest periods of undisturbed experimentation can be carried out? Insight into the answers to these questions can be gained by examining the coefficients of the solutions. The secular terms will yield the long-term drift rate while the coefficients of the harmonic terms are useful for assessing short-term effects. In addition, the determination of trajectories which lead to the smallest secular variations give one of the best means for establishing initial coordinate locations for experiment packages. It can also be seen that orbits which lead to periodic returns to the origin can be studied by this means. Such orbits could, of course, be quite useful for recapturing experiment packages or, alternatively, for keeping ejected packages away from the origin if so desired, thus removing any possibility of future interaction of package and station.

It can be seen that studies of this nature are highly dependent on the accuracy of the secular terms, and a good premium should be placed on getting these terms correctly. It will be found in the next chapter that there are advantages along these lines to be achieved if rectangular coordinates with their complexity are discarded in favor of nonrectangular systems, for just this reason; that is, in some directions, secular terms can be simplified and thus lead to better overall results. Rectangular coordinates are still quite useful in the vicinity of the origin, nevertheless, because of the inherent orthogonality of the system. Equations so developed are often simpler to implement and visualize, while retaining an acceptable degree of accuracy. It can be seen in figures 3-4 and 3-5 for London's equations and in figures 3-6 and 3-7 for the Anthony and Sasaki equations that relatively small departure velocities are specified. The necessity for the small departure velocities becomes painfully apparent when one scales the equations to a small gravitational body such as the moon. In the next chapter an attempt will be made to overcome this difficulty by adopting shell coordinates which are themselves curved so as to compensate for the curvature of the orbit.

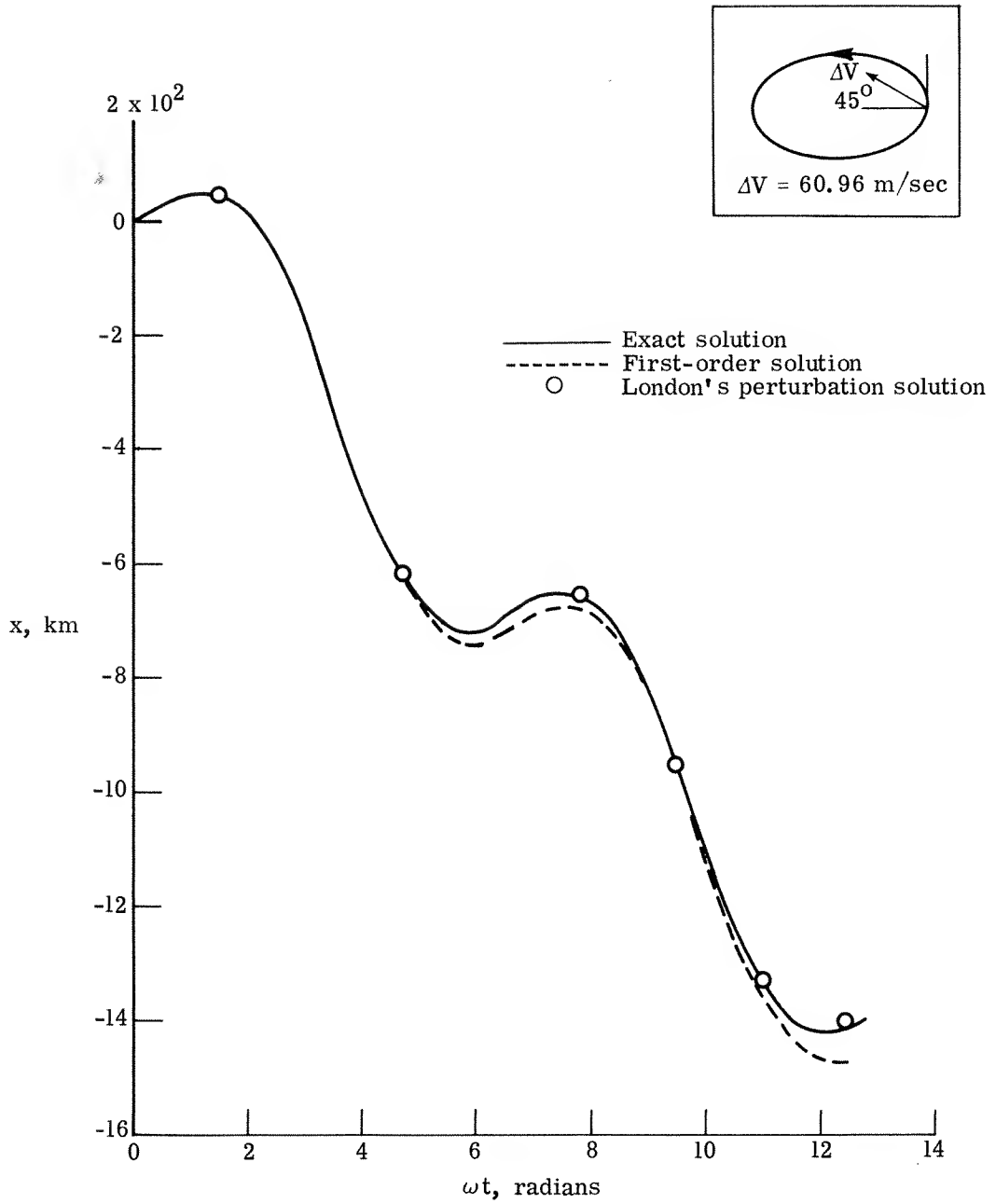

Figure 3-4.- Comparison of London's solution with first-order theory and exact theory for a typical earth orbital trajectory in the x-direction.

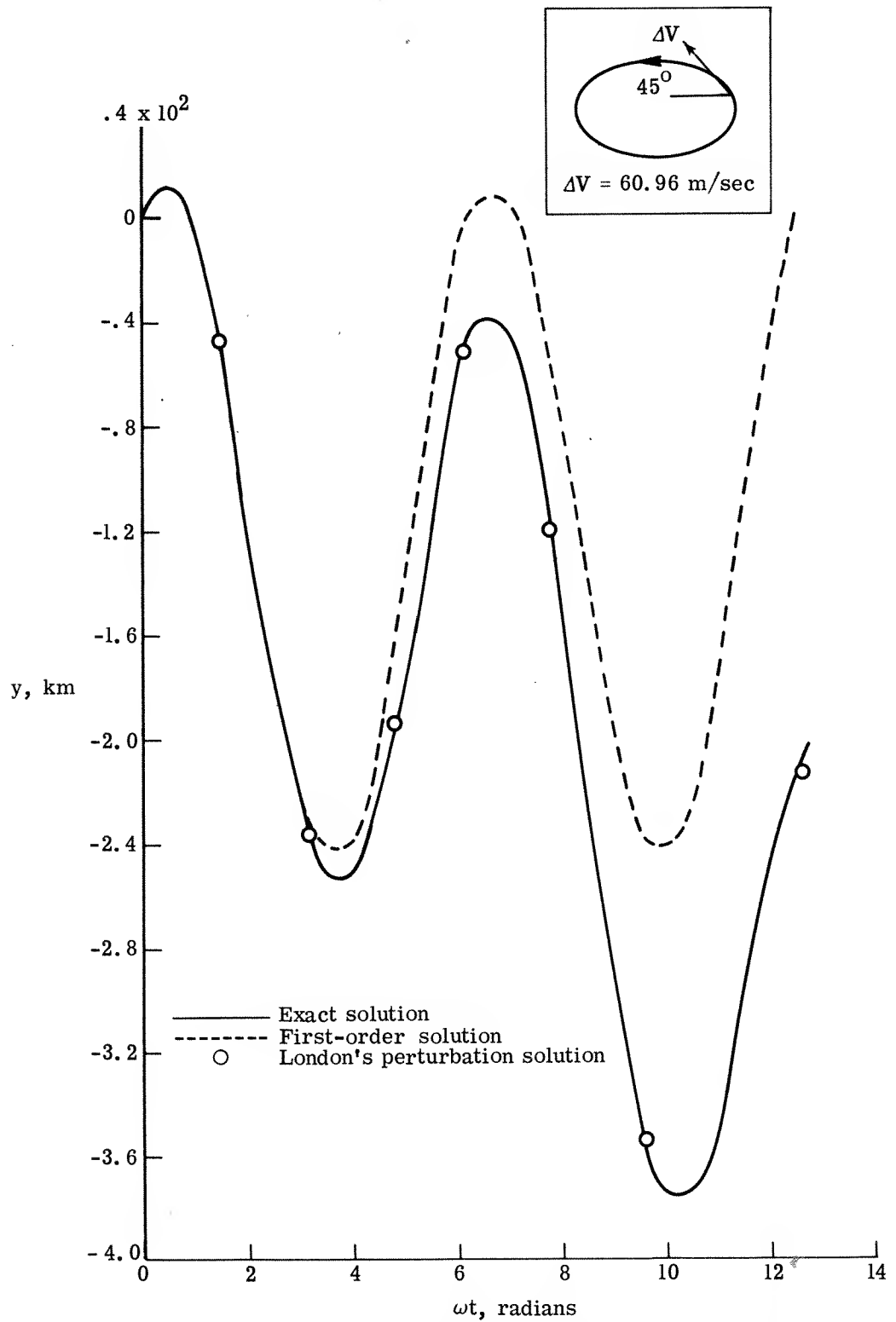

Figure 3-5.- Comparison of London's solution with first-order theory and exact theory for a typical earth orbital trajectory in the y-direction.

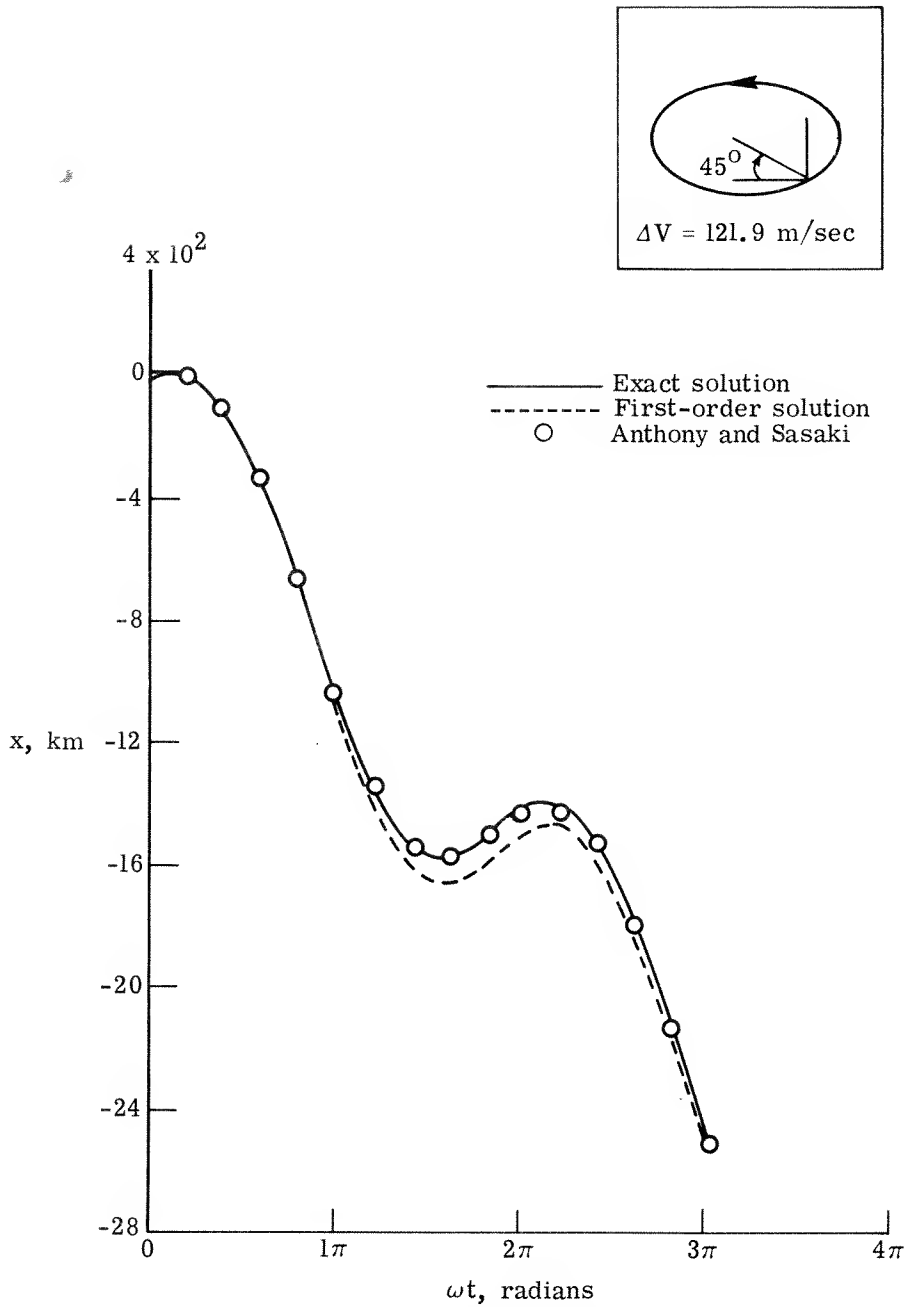

Figure 3-6.- Comparison of Anthony and Sasaki's perturbation solution with first-order theory and exact theory for a typical earth trajectory in the x-direction.

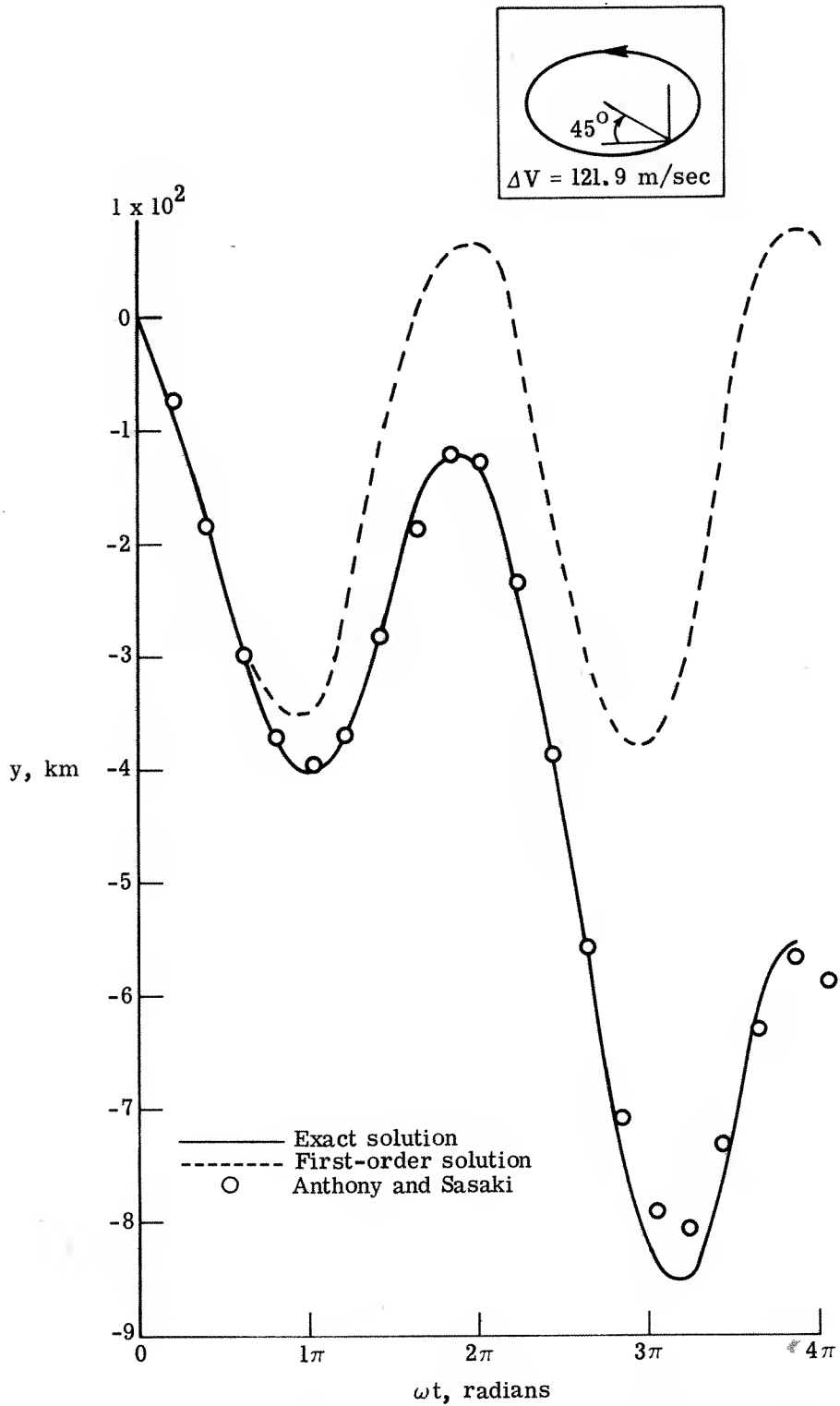
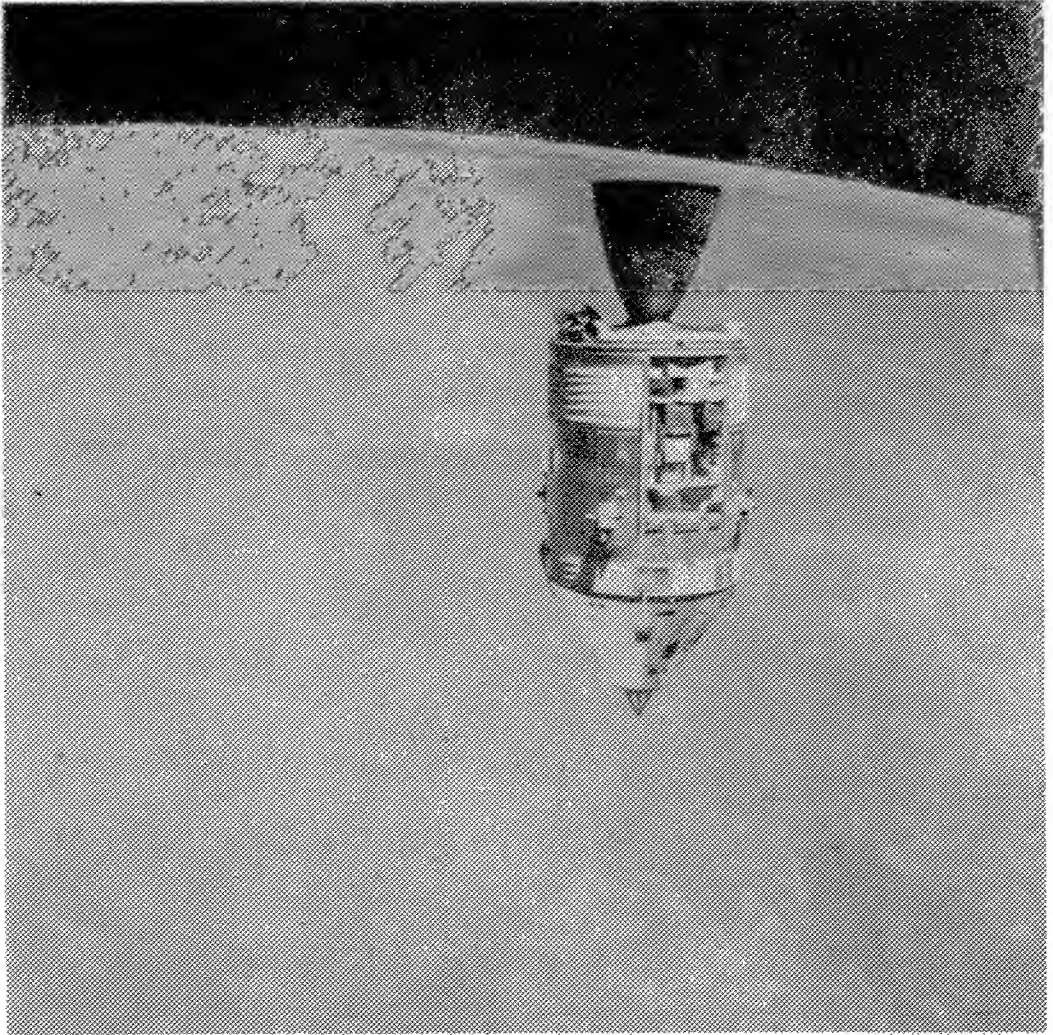

Figure 3-7.- Comparison of Anthony and Sasaki's perturbation solution with first-order theory and exact theory for a typical earth orbital trajectory in the y-direction.

CHAPTER 4
RELATIVE MOTION IN NONRECTANGULAR COORDINATES



L-73-3012

Apollo Command/Service Module as seen from the Landing Module just after rendezvous. The lunar near side is in the background.

CHAPTER 4

RELATIVE MOTION IN NONRECTANGULAR COORDINATES

In the previous chapter, relative motion in rectangular coordinates was taken up in some detail. The center of the coordinate frame, however, moves along a curved path, and the question naturally arises as to what can be gained by the use of nonrectangular coordinate systems. It turns out that, in some cases, such as spherical moving coordinates, nothing in particular can be gained except, perhaps, some modest degree of elegance. If, however, a curved coordinate system centered on the earth is employed, substantial increases in accuracy over long time periods can be attained. This improvement is brought about by various types of more efficient equalization between the dynamic terms and the gravity expansion; that is, curving the coordinate system results in a set of coordinates that is more "natural" to the dynamic physical situation. This advantage is usually expressed in the final result as a lessening in the number of secular terms necessary to achieve the desired level of accuracy or, alternatively, as an improvement in the accuracy of the secular term coefficients. This advantage does not mean that on the short time scale curved coordinates are necessarily more accurate, although they frequently are, but it does mean that, for large separation distances or large relative velocities, the curved coordinate systems stay accurate longer. Naturally, the more curved the orbital situation the more one can expect to gain from curved coordinates. This characteristic makes them especially attractive for smaller gravitational bodies such as the moon.

In this chapter, a simple spherical coordinate transformation of the Clohessy-Wiltshire equations will be taken up first. This transformation provides a simple and useful transition into nonrectangular modes of thought. Next, shell coordinates will be used, taking up, successively, first- and second-order systems. Finally, one of the more successful correction factors which has been tried for the rendezvous equations will be studied. This solution is developed by comparing the first-order rendezvous equations with the known exact solution when both rendezvous and target vehicle are in the same circular orbit. In the course of this development, it will be seen why these systems are good when they are good, and why they fail when they fail. The overwhelming dominance and persistence of the concepts of angular momentum and energy conservation will also be seen more clearly than before.

Spherical Coordinates

The equations used to define the relative motion with respect to a rotating coordinate system have been presented previously as equations (3-9), (3-10), and (3-11). In order to effect the change into spherical coordinates, make the following transformations (see fig. 4-1):

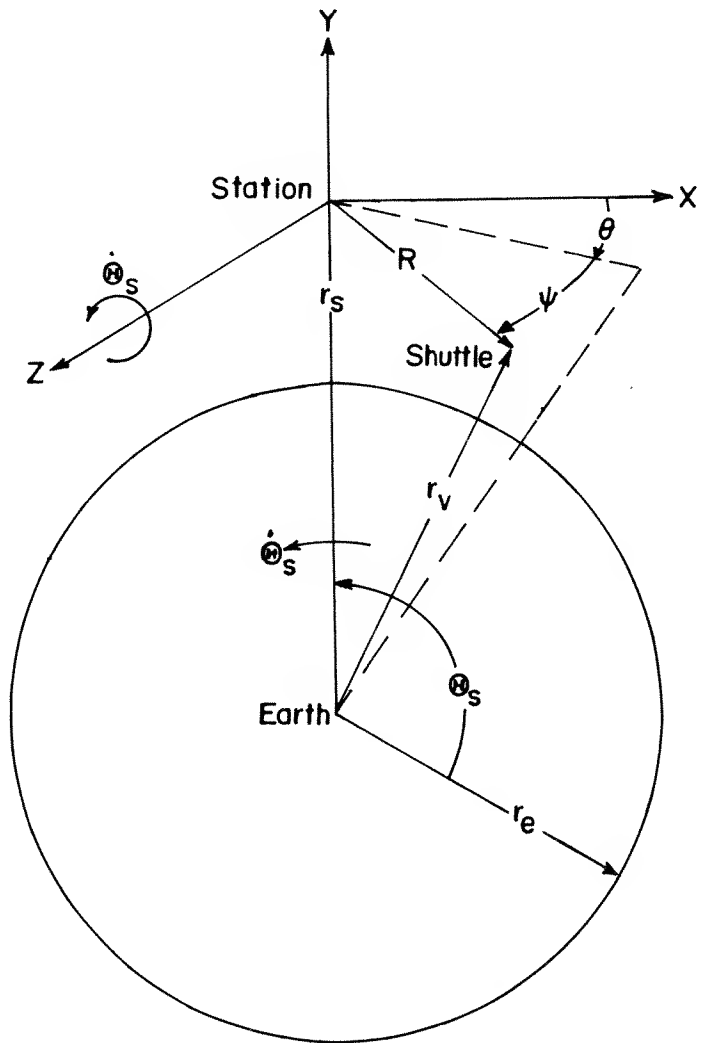

Figure 4-1.- Coordinates employed in describing the motions of the space station and shuttle.

$$\left. \begin{aligned} x &= R \cos \psi \cos \vartheta \\ y &= -R \cos \psi \sin \vartheta \\ z &= R \sin \psi \end{aligned} \right\} \quad (4-1)$$

If this transformation is applied to equation (3-8) the Lagrangian which results is

$$\begin{aligned} L = & \frac{1}{2} m \left(\dot{R}^2 + R^2 \dot{\psi}^2 + R^2 \dot{\vartheta}^2 \cos^2 \psi - 2\dot{R}\dot{r}_S \cos \psi \sin \vartheta + 2R\dot{r}_S \dot{\psi} \sin \psi \sin \vartheta \right. \\ & \left. - 2R\dot{r}_S \dot{\vartheta} \cos \psi \cos \vartheta + \dot{r}_S^2 \right) + m\dot{\Theta}_S \left[(R\dot{r}_S - \dot{R}r_S) \cos \psi \cos \vartheta - R^2 \dot{\vartheta} \cos^2 \psi \right. \\ & \left. + Rr_S \dot{\psi} \sin \psi \cos \vartheta + Rr_S \dot{\vartheta} \cos \psi \sin \vartheta \right] + \frac{1}{2} m\dot{\Theta}_S^2 (R^2 \cos^2 \psi \\ & - 2Rr_S \cos \psi \sin \vartheta + r_S^2) + \frac{mg_e r_e^2}{r_v} \end{aligned} \quad (4-2)$$

where

$$r_v = \left[x^2 + (y + r_S)^2 + z^2 \right]^{1/2} = \left(R^2 + r_S^2 \pm 2Rr_S \cos \psi \sin \vartheta \right)^{1/2}$$

The equations of motion corresponding to equations (3-9), (3-10), and (3-11) are

$$\begin{aligned} \ddot{R} - R\dot{\psi}^2 - R(\dot{\vartheta} - \dot{\Theta}_S)^2 \cos^2 \psi + \left[r_S \left(\dot{\Theta}_S^2 - \frac{g_e r_e^2}{r_v^3} \right) - \ddot{r}_S \right] \cos \psi \sin \vartheta \\ - \left(r_S \ddot{\Theta}_S + 2\dot{r}_S \dot{\Theta}_S \right) \cos \psi \cos \vartheta + \frac{g_e r_e^2 R}{r_v^3} = 0 \end{aligned} \quad (4-3)$$

$$\begin{aligned} \left[R\ddot{\vartheta} + 2\dot{R}(\dot{\vartheta} - \dot{\Theta}_S) - R\ddot{\Theta}_S \right] \cos \psi - 2R\dot{\psi}(\dot{\vartheta} - \dot{\Theta}_S) \sin \psi \\ + \left(r_S \ddot{\Theta}_S + 2\dot{r}_S \dot{\Theta}_S \right) \sin \vartheta + \left[r_S \left(\dot{\Theta}_S^2 - \frac{g_e r_e^2}{r_v^3} \right) - \ddot{r}_S \right] \cos \vartheta = 0 \end{aligned} \quad (4-4)$$

$$\begin{aligned} R\ddot{\psi} + 2\dot{R}\dot{\psi} + R(\dot{\vartheta} - \dot{\Theta}_S)^2 \sin \psi \cos \psi + \left(r_S \ddot{\Theta}_S + 2\dot{r}_S \dot{\Theta}_S \right) \sin \psi \cos \vartheta \\ - \left[r_S \left(\dot{\Theta}_S^2 - \frac{g_e r_e^2}{r_v^3} \right) - \ddot{r}_S \right] \sin \psi \sin \vartheta = 0 \end{aligned} \quad (4-5)$$

In the special case where the station is in a circular orbit r_s and $\dot{\Theta} = \omega$ are constants, and equations (4-3), (4-4), and (4-5) reduce to the form

$$\ddot{R} - R\dot{\psi}^2 - R(\dot{\vartheta} - \omega)^2 \cos^2 \psi + \left(\omega^2 - \frac{g_e r_e^2}{r_v^3} \right) r_s \cos \psi \sin \vartheta + \frac{g_e r_e^2 R}{r_v^3} = 0 \quad (4-6)$$

$$\left[R\ddot{\vartheta} + 2\dot{R}(\dot{\vartheta} - \omega) \right] \cos \psi - 2R\dot{\psi}(\dot{\vartheta} - \omega) \sin \psi + \left(\omega^2 - \frac{g_e r_e^2}{r_v^3} \right) r_s \cos \vartheta = 0 \quad (4-7)$$

$$R\ddot{\psi} + 2\dot{R}\dot{\psi} + R(\dot{\vartheta} - \omega)^2 \sin \psi \cos \psi - \left(\omega^2 - \frac{g_e r_e^2}{r_v^3} \right) r_s \sin \psi \sin \vartheta = 0 \quad (4-8)$$

As before, for the case of a station in a circular orbit, the equations of motion in terms of the rectangular coordinate system (eqs. (3-13), (3-14), and (3-15)) may be linearized and, therefore, solved in closed form by approximating the gravity difference between the two vehicles. Thus

$$\frac{g_e r_e^2}{r_v^3} \approx \frac{g_e r_e^2}{r_s^3} \left(1 - 3 \frac{y}{r_s} \right) \quad (4-9)$$

This approximation represents a rotating parallel gravitational field rather than the spherical field of equation (3-22). The application of equation (4-9) yields equations (3-26), (3-27), and (3-28) as was done before in chapter 3:

$$\ddot{x} - 2\omega\dot{y} = 0 \quad (3-26)$$

$$\ddot{y} + 2\omega\dot{x} - 3\omega^2 y = 0 \quad (3-27)$$

$$\ddot{z} + \omega^2 z = 0 \quad (3-28)$$

These equations have the solutions:

$$x = 2 \left(2 \frac{\dot{x}_0}{\omega} - 3y_0 \right) \sin \omega t - 2 \frac{\dot{y}_0}{\omega} \cos \omega t + \left(6y_0 - 3 \frac{\dot{x}_0}{\omega} \right) \omega t + 2 \frac{\dot{y}_0}{\omega} + x_0 \quad (3-29)$$

$$y = \left(2 \frac{\dot{x}_0}{\omega} - 3y_0 \right) \cos \omega t + \frac{\dot{y}_0}{\omega} \sin \omega t + 4y_0 - 2 \frac{\dot{x}_0}{\omega} \quad (3-30)$$

$$z = z_0 \cos \omega t + \frac{\dot{z}_0}{\omega} \sin \omega t \quad (3-31)$$

Inverting these equations to form guidance equations yields the, by now well-established, set of equations to rendezvous in time τ_1

$$\frac{\dot{x}_c}{\omega} = \frac{x_0 (\sin \omega \tau_1) + y_0 [6\omega \tau_1 \sin \omega \tau_1 - 14(1 - \cos \omega \tau_1)]}{3\omega \tau_1 \sin \omega \tau_1 - 8(1 - \cos \omega \tau_1)} \quad (3-32)$$

$$\frac{\dot{y}_c}{\omega} = \frac{2x_0(1 - \cos \omega\tau_1) + y_0(4 \sin \omega\tau_1 - 3\omega\tau_1 \cos \omega\tau_1)}{3\omega\tau_1 \sin \omega\tau_1 - 8(1 - \cos \omega\tau_1)} \quad (3-33)$$

$$\frac{\dot{z}_c}{\omega} = -\frac{z_0}{\tan \omega\tau_1} \quad (3-34)$$

For simplicity, make the substitution

$$\Lambda = 3\omega\tau_1 \sin \omega\tau_1 - 8(1 - \cos \omega\tau_1) \quad (4-10)$$

In terms of the spherical coordinates R , ψ , and ϑ , equations (3-32), (3-33), and (3-34) become, respectively,

$$\frac{\dot{R}_c}{\omega R_0} = \left(K_2 + K_3 \sin^2 \vartheta_0 - K_4 \sin \vartheta_0 \cos \vartheta_0 \right) \cos^2 \psi_0 + K_1 \sin^2 \psi_0 \quad (4-11)$$

$$\frac{\dot{\psi}_c}{\omega} = \left(K_1 - K_2 - K_3 \sin^2 \vartheta_0 + K_4 \sin \vartheta_0 \cos \vartheta_0 \right) \sin \psi_0 \cos \psi_0 \quad (4-12)$$

$$\frac{\dot{\vartheta}_c}{\omega} = K_3 \sin \vartheta_0 \cos \vartheta_0 + K_4 \sin^2 \vartheta_0 - K_5 \quad (4-13)$$

where

$$\left. \begin{aligned} K_1 &= -\cos \omega\tau_1 \\ K_2 &= \frac{1}{\Lambda} \sin \omega\tau_1 \\ K_3 &= \frac{3}{\Lambda} (\sin \omega\tau_1 - \omega\tau_1 \cos \omega\tau_1) \\ K_4 &= \frac{6}{\Lambda} (\omega\tau_1 - 2 + 2 \cos \omega\tau_1) \\ K_5 &= \frac{2}{\Lambda} (1 - \cos \omega\tau_1) \end{aligned} \right\} \quad (4-14)$$

These then are the Clohessy-Wiltshire equations in spherical-coordinate form. They are useful where spherical symmetry about the origin is inherent to the nature of the problem as, for instance, if measurements are to be made by a radar located on the station. They are not, however, any more accurate than the rectangular version and, hence, have seldom been used either in computer studies where the rectangular coordinates are just as easy to use, or in actual hardware where coordinate conversion has been the rule. They do, however, show in an elegant manner the separation of range rate from angular rate.

Shell Coordinates

It is now informative to look at the form the relative motion equations take in shell coordinates. The coordinate system employed in this development (ref. 10) is shown in figure 4-2 where r is the projection of a line connecting the center of the

planet to the orbital vehicle upon the plane of the reference vehicle. The symbol z is normal to this plane passing through the orbital vehicle; y is measured along r from the reference vehicle altitude to the projection of the maneuvering vehicle with the positive direction upward; and x is measured in a curved arc backward along the flight path of the reference vehicle in the plane of the reference vehicle orbit to r . The coordinate system rotates about the origin with angular velocity $\dot{\theta}$. It should be noted that this is a left-handed coordinate system as opposed to all of the previous coordinate systems which were right-handed.

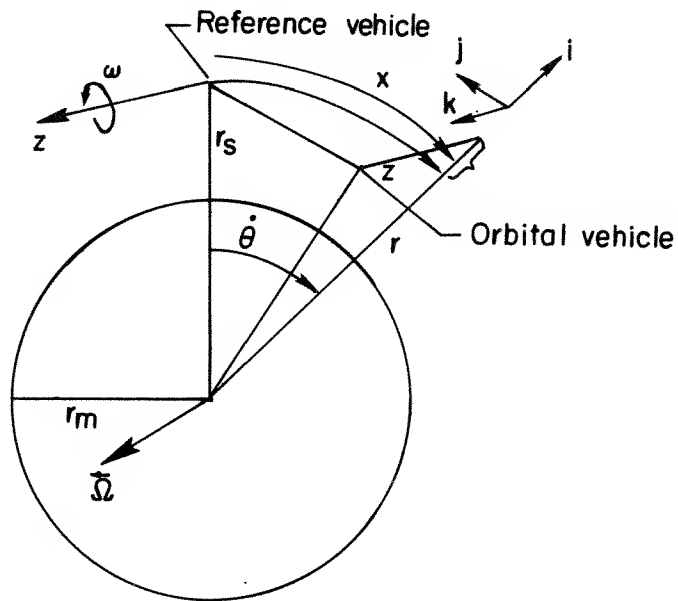
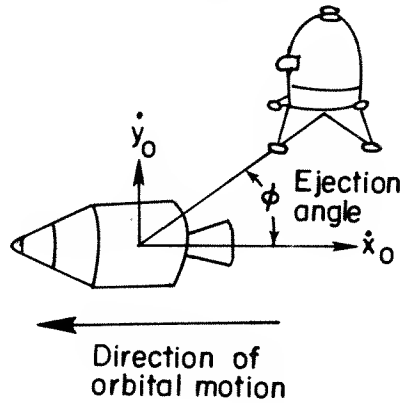

Figure 4-2.- Coordinates employed in describing the motions of the vehicles.

Two assumptions are made about the physical nature of the problem. They are: (1) the attracting planetary mass is a gravitational sphere, and (2) the body upon which the coordinate system is centered is in a circular orbit. Small departures from these assumptions are not considered serious.

In a cylindrical coordinate system centered on the planetary body the Lagrangian is

$$L = \frac{1}{2} m (\dot{r}^2 + r^2 \dot{\theta}^2 + \dot{z}^2) - mr^2 \omega \dot{\theta} + \frac{1}{2} m \omega^2 r^2 \frac{mg_e r_e^2}{\sqrt{r^2 + z^2}} \quad (4-15)$$

Equations (4-1) are converted to shell coordinates by means of the following substitutions:

$$\left. \begin{aligned} y + r_s &= r \\ x &= r_s \theta \\ z &= z \end{aligned} \right\} \quad (4-16)$$

Hence

$$\left. \begin{aligned} \dot{y} &= \dot{r} \\ \dot{x} &= r_s \dot{\theta} \\ \dot{z} &= \dot{z} \end{aligned} \right\} \quad (4-17)$$

Then, in shell coordinates, the Lagrangian becomes

$$L = \frac{1}{2} m \left[\dot{y}^2 + \dot{z}^2 + (y + r_s)^2 \left(\frac{\dot{x}}{r_s} - \omega \right)^2 + \frac{2g_e r_e^2}{\sqrt{(y + r_s)^2 + z^2}} \right] \quad (4-18)$$

The differential equations of motion which follow from this Lagrangian are

$$\ddot{x} + \frac{\ddot{x}y}{r_s} + \frac{2\dot{x}\dot{y}}{r_s} - 2\omega\dot{y} = 0 \quad (4-19)$$

$$\ddot{y} - (y + r_s) \left\{ \left(\frac{\dot{x}}{r_s} - \omega \right)^2 - \frac{g_e r_e^2}{r_s^3} \left[\left(1 + \frac{y}{r_s} \right)^2 + \left(\frac{z}{r_s} \right)^2 \right]^{-3/2} \right\} = 0 \quad (4-20)$$

$$\ddot{z} + \frac{g_e r_e^2}{r_s^3} z \left[\left(1 + \frac{y}{r_s} \right)^2 + \left(\frac{z}{r_s} \right)^2 \right]^{-3/2} = 0 \quad (4-21)$$

These are the exact differential equations of motion as seen from the orbiting vehicle. It can be seen immediately that equation (4-19) is cyclic in the x-coordinate; thus, a first integral of the equation of motion in the x-direction is found immediately. The integral merely expresses the law of conservation of angular momentum.

If use is made of the exact orbital expression,

$$\omega^2 = \frac{g_e r_e^2}{r_s^3} \quad (3-16)$$

and equation (4-19) is integrated, the equations of motion become

$$\left(\frac{\dot{x}}{\omega r_s} - 1\right)\left(1 + \frac{y}{r_s}\right)^2 = K \quad (4-22)$$

$$\ddot{y} - (y + r_s) \left\{ \left(\frac{\dot{x}}{r_s} - \omega\right)^2 - \omega^2 \left[\left(1 + \frac{y}{r_s}\right)^2 + \left(\frac{z}{r_s}\right)^2 \right]^{-3/2} \right\} = 0 \quad (4-23)$$

$$\ddot{z} + \omega^2 z \left[\left(1 + \frac{y}{r_s}\right)^2 + \left(\frac{z}{r_s}\right)^2 \right]^{-3/2} = 0 \quad (4-24)$$

For convenience, let

$$\left. \begin{aligned} X &= \frac{x}{r_s} \\ Y &= \frac{y}{r_s} \\ Z &= \frac{z}{r_s} \\ \tau &= \omega t \end{aligned} \right\} \quad (4-25)$$

The resulting equations are

$$\dot{X} - 1 = \frac{K}{(1 + Y)^2} \quad (4-26)$$

$$\ddot{Y} - (Y + 1) \left\{ (\dot{X} - 1)^2 - \left[(1 + Y)^2 + Z^2 \right]^{-3/2} \right\} = 0 \quad (4-27)$$

$$\ddot{Z} + Z \left[(1 + Y)^2 + Z^2 \right]^{-3/2} = 0 \quad (4-28)$$

where the dot over the symbols now refers to the derivative with respect to τ . The approach taken in obtaining the solutions is the following: Equation (4-27) contains terms in \dot{X} but not in X . The term Z^2 is assumed to be small in relation to $(1 + Y)^2$ and can hence be neglected. For instance, typical dimensional values of x and y are on the order of 100 km or less, making Z or Y on the order of $\frac{100}{1936} \approx 0.107$ as compared to 1. Thus, it is possible to cast equation (4-27) as an equation in Y and \ddot{Y} by direct substitution of the right-hand side of equation (4-26). Equation (4-27) can then be solved approximately for Y as an explicit function of time. The solution so obtained may then be used in the solution of equations (4-26) and (4-28).

In order to establish a value for K , assume that at time equals zero

$$\left. \begin{aligned} \tau &= 0 \\ \dot{X} &= \dot{X}_0 \\ Y &= Y_0 \end{aligned} \right\} \quad (4-29)$$

It follows that $K = (\dot{X}_0 - 1)(1 + Y_0)^2$. Substituting the right-hand side of equation (4-26) into equation (4-27) and neglecting the out-of-plane term Z results in

$$\ddot{Y} - \frac{K^2}{(1 + Y)^3} + \frac{1}{(1 + Y)^2} = 0 \quad (4-30)$$

If the forms of

$$\frac{1}{(1 + Y)^n}$$

where $n = 2$ or 3 are expanded, and the terms of the second order and lower are retained, equations (4-26), (4-27), and (4-28) become

$$\dot{X} + 2KY - (K + 1) = 3KY^2 \quad (4-31)$$

$$\ddot{Y} + \alpha^2 Y - \beta^2 = -\lambda Y^2 \quad (4-32)$$

$$\ddot{Z} + Z = 3YZ \quad (4-33)$$

where

$$K = (\dot{X}_0 - 1)(1 + Y_0)^2 \quad (4-34)$$

$$\left. \begin{aligned} \alpha^2 &= 3K^2 - 2 \\ \beta^2 &= K^2 - 1 \\ \lambda &= -6K^2 + 3 \end{aligned} \right\} \quad (4-35)$$

First-Order Solutions

The first-order solutions to equations (4-31), (4-32), and (4-33) are obtained by dropping the second-order terms (setting the terms on the right-hand side of eqs. (4-31), (4-32), and (4-33) equal to zero). The Y -equation is solved by inspection. Its solution is

$$Y = a' \cos(\alpha\tau + \zeta') + \frac{\beta^2}{\alpha^2} \quad (4-36)$$

where primes are used to distinguish first-order-equation integration constants a and ζ from those of the second-order which will be developed in the next section.

The X-equation becomes, upon replacing $K + 1$ with its equivalent by definition \dot{X}_0

$$\dot{X} = \dot{X}_0 - 2KY \quad (4-37)$$

Then, substituting the right-hand side of equation (4-36) into equation (4-37) for Y and integrating, the X-equation is

$$X = \left(\dot{X}_0 - \frac{2K\beta^2}{\alpha^2} \right) \tau - 2 \frac{Ka'}{\alpha} \sin(\alpha\tau + \zeta') + \frac{2Ka'}{\alpha} \sin \zeta' + X_0 \quad (4-38)$$

A solution to the Z-equation is

$$Z = \dot{Z}_0 \sin \tau + Z_0 \cos \tau \quad (4-39)$$

where $Z = Z_0$ at $\tau = 0$ and $\dot{Z} = \dot{Z}_0$.

In order to compute the integration constants from the initial conditions, set $Y = Y_0$ at $\tau = 0$ and $\dot{Y} = \dot{Y}_0$. Then solve for a' and ζ' . This solution can be found in a straightforward manner; but, for purposes of making the second-order equivalent development which will be undertaken shortly more understandable, it is advisable to make the substitution

$$u' = a' \cos \zeta' \quad (4-40)$$

Taking the derivative with respect to time of equation (4-36) and applying initial conditions at $\tau = 0$ gives

$$\dot{Y}_0 = -a'\alpha \sin \zeta' \quad (4-41)$$

Then by squaring both equations and adding, making use of the identity $\sin^2 \zeta' + \cos^2 \zeta' = 1$, a quadratic in a' is obtained

$$\alpha^2 u'^2 + \dot{Y}_0^2 = \alpha^2 a'^2 \quad (4-42)$$

for which the solution

$$a' = \sqrt{u'^2 + \left(\frac{\dot{Y}_0}{\alpha} \right)^2} \quad (4-43)$$

where

$$u' = Y_0 - \frac{\beta^2}{\alpha^2} \quad (4-44)$$

is obtained by applying terminal conditions to equation (4-36) at $\tau = 0$. Hence

$$a' = \sqrt{\left(Y_0 - \frac{\beta^2}{\alpha^2} \right)^2 + \left(\frac{\dot{Y}_0}{\alpha} \right)^2} \quad (4-45)$$

Then it follows easily that

$$\zeta' = \cos^{-1} \left(\frac{u'}{a'} \right) \quad (4-46)$$

The sign selection on equations (4-45) and (4-46) can be done empirically; for instance, a' can be chosen always positive and then the quadrant for ζ' depends upon the launch angle ϕ . Equation (4-36) can be expressed explicitly without the epoch angle as

$$Y = -\frac{\beta^2}{\alpha^2} \cos \alpha\tau + \frac{\dot{Y}_O}{\alpha} \sin \alpha\tau + \frac{\beta^2}{\alpha^2} \quad (4-47)$$

Expanding $\cos(\alpha\tau + \zeta')$ in equation (4-36) yields

$$Y = (a' \cos \zeta') \cos \alpha\tau - (a' \sin \zeta') \sin \alpha\tau + \frac{\beta^2}{\alpha^2} \quad (4-48)$$

Comparison of equations (4-47) and (4-48) gives

$$\left. \begin{aligned} a' \cos \zeta' &= -\frac{\beta^2}{\alpha^2} \\ a' \sin \zeta' &= -\frac{\dot{Y}_O}{\alpha} \end{aligned} \right\} \quad (4-49)$$

Hence,

$$\tan \zeta' = \frac{-\dot{Y}_O/\alpha}{-\beta^2/\alpha^2} \quad (4-50)$$

In equation (4-50), since α is a frequency, which is a physical quantity, a negative α has no meaning. It can thus be seen that the sign of $\tan \zeta'$ can be determined by using positive values of α and letting the signs of \dot{Y}_O and β^2 determine the quadrant. It should be pointed out that β^2 is not necessarily positive due to its definition, which permits imaginary values of β . It can be seen, however, that β^2 is strictly a function of \dot{X}_O and Y_O and always has the opposite sign to \dot{X}_O . The reason is that β^2 , assuming reasonably small values of Y_O , is

$$\beta^2 = \dot{X}_O(\dot{X}_O - 2)$$

It then follows, once a quadrant has been selected for ζ' , that equations (4-49) give the sign to be selected for a' in equation (4-45). It is found that a positive selection for a' is the correct selection. These characteristics for all possible ejection quadrants are given in table 4-I. Thus table 4-I relates the ζ' -quadrant and the ϕ -quadrant (ejection angle) for the first-order solutions.

TABLE 4-I.- FIRST-ORDER QUADRANT AND SIGN SELECTION

\dot{X}_O	\dot{Y}_O	β^2	ζ' quadrant	a'	ϕ quadrant
+	+	-	4	+	1
-	+	+	3	+	2
-	-	+	2	+	3
+	-	-	1	+	4

Second-Order Solutions

Solution for Y .- Equation (4-32) can be expressed as

$$\ddot{Y} + \alpha^2 Y + \lambda Y^2 = \beta^2 \quad (4-51)$$

It is advantageous, in order to eliminate the constant β on the right-hand side of equation (4-51), to transform this equation into the form

$$\ddot{V} + \rho^2 V + \lambda V^2 = 0 \quad (4-52)$$

This transformation can be accomplished by a change in variable. Let $Y = V + M$ where M is a constant. The transformation results in

$$\ddot{V} + (\alpha^2 + 2\lambda M)V + \lambda V^2 = \beta^2 - \lambda M^2 - \alpha^2 M \quad (4-53)$$

The right-hand side of equation (4-53) thus becomes a function of some still undetermined constant M . Since the choice of M is not fixed, a value can be chosen which makes the right-hand side vanish. Comparing equations (4-51) and (4-52) shows that

$$\beta^2 - \lambda M^2 - \alpha^2 M = 0 \quad (4-54)$$

and

$$\alpha^2 + 2\lambda M = \rho^2 \quad (4-55)$$

which can also be written as

$$\rho^2 = \sqrt{-15K^4 + 24K^2 - 8} \quad (4-56)$$

Solving equation (4-54) for M yields

$$M = -\frac{\alpha^2}{2\lambda} \pm \left(\frac{\beta^2}{\lambda} + \frac{\alpha^4}{4\lambda^2} \right)^{1/2} \quad (4-57)$$

which can also be expressed in terms of ρ^2 as

$$M = -\frac{\alpha^2 - \rho^2}{2\lambda} \quad (4-58)$$

Equation (4-52) may be recognized as the equation of a one-dimensional anharmonic oscillator. An exact second integral of this equation may be obtained if desired; however, as this solution is an elliptic integral, the results are not very useful for solving the X - and Z -equations. For this reason an approximate perturbation solution is sought. A more complete treatment than that given here using higher-order terms can be found in reference 11. The solution V is obtained as the sum of a first-order solution V_1 and a second-order correction term V_2 . Let

$$V = V_1 + V_2 \quad (4-59)$$

The first-order solution to this equation (by assuming $\rho^2 \gg \lambda V$) is

$$V_1 = a \cos(\rho\tau + \zeta) \quad (4-60)$$

from which equation (4-59) becomes

$$V = a \cos(\rho\tau + \zeta) + V_2 \quad (4-61)$$

Applying these relations to equation (4-52) gives

$$\begin{aligned} & -\rho^2 a \cos(\rho\tau + \zeta) + \ddot{V}_2 + \rho^2 a \cos(\rho\tau + \zeta) + \rho^2 V_2 \\ & + \lambda \left[a^2 \cos^2(\rho\tau + \zeta) + 2aV_2 \cos(\rho\tau + \zeta) + V_2^2 \right] \end{aligned} \quad (4-62)$$

After some cancellation and rearrangement of terms,

$$\ddot{V}_2 + \rho^2 V_2 = -\lambda a^2 \cos^2(\rho\tau + \zeta) - 2\lambda a V_2 \cos(\rho\tau + \zeta) - \lambda V_2^2 \quad (4-63)$$

Omitting terms of higher order than the second (last two terms on right) results in

$$\ddot{V}_2 + \rho^2 V_2 = -\lambda a^2 \cos^2(\rho\tau + \zeta) = -\frac{1}{2} \lambda a^2 - \frac{1}{2} \lambda a^2 \cos 2(\rho\tau + \zeta) \quad (4-64)$$

Solving the inhomogeneous linear equation in the usual way yields

$$V_2 = -\frac{\lambda a^2}{2\rho^2} + \frac{\lambda a^2}{6\rho^2} \cos 2(\rho\tau + \zeta) \quad (4-65)$$

Hence, the second-order solution for V is

$$V = a \cos(\rho\tau + \zeta) - \frac{\lambda a^2}{2\rho^2} + \frac{\lambda a^2}{6\rho^2} \cos 2(\rho\tau + \zeta) \quad (4-66)$$

The constants a and ζ are integration constants which depend on initial conditions. This solution is, of course, limited to cases where the first-order assumption is approximately valid; that is,

$$\lambda V \ll \rho^2$$

or

$$\lambda(Y - M) \ll \rho^2$$

It can be seen from numerical solution that this relationship is usually the case since Y seldom exceeds 0.1 for cases which are physically practical and M will be small provided the departure velocity is small enough.

Converting equation (4-66) to Y notation yields

$$Y = a \cos(\rho\tau + \zeta) - \frac{\lambda a^2}{2\rho^2} \left[1 - \frac{1}{3} \cos 2(\rho\tau + \zeta) \right] - \frac{\alpha^2 - \rho^2}{2\lambda} \quad (4-67)$$

The last term on the right is part of a small correction term which takes account of the change in energy and hence the change in average altitude between the original circular orbit and the new orbit into which the vehicle is launched.

Solution for X.- The second-order solution for X is obtained by substituting equation (4-67) for Y in equation (4-31) for \dot{X} and then integrating. The differential equation is

$$\begin{aligned} \dot{X} = \dot{X}_0 - 2K \left[a \cos(\rho\tau + \zeta) + \frac{\lambda a^2}{6\rho^2} \cos 2(\rho\tau + \zeta) - \frac{\lambda a^2}{2\rho^2} - \frac{\alpha^2}{2\lambda} + \frac{\rho^2}{2\lambda} \right] + 3K \left[a^2 \cos^2(\rho\tau + \zeta) \right. \\ \left. + \frac{\lambda^2 \alpha^4}{36\rho^4} \cos^2 2(\rho\tau + \zeta) + \frac{\lambda^2 \alpha^4}{4\rho^4} + \frac{a^2 \alpha^2}{2\rho^2} + \frac{\alpha^4}{2\lambda^2} + \frac{\beta^2}{\lambda} - \left(\frac{\lambda a^2}{\rho^2} + \frac{\alpha^2}{\lambda} \right) \frac{\rho^2}{2\lambda} + \frac{2\lambda a^3}{3\rho^2} \cos^3(\rho\tau + \zeta) \right. \\ \left. - \frac{4\lambda a^3}{3\rho^2} \cos(\rho\tau + \zeta) - \frac{\alpha^2 a}{\lambda} \cos(\rho\tau + \zeta) + \frac{\rho^2 a}{\lambda} \cos(\rho\tau + \zeta) - \frac{\lambda^2 a^4}{6\rho^4} \cos 2(\rho\tau + \zeta) \right. \\ \left. - \frac{a^2 \alpha^2}{6\rho^2} \cos 2(\rho\tau + \zeta) + \frac{a^2}{6} \cos 2(\rho\tau + \zeta) \right] \end{aligned} \quad (4-68)$$

Integrating equation (4-68) with respect to τ with A as an arbitrary constant of integration yields

$$\begin{aligned} X = A + B\tau + C \sin(\rho\tau + \zeta) + D \sin 2(\rho\tau + \zeta) + E \sin 3(\rho\tau + \zeta) \\ + F \sin 4(\rho\tau + \zeta) \end{aligned} \quad (4-69)$$

where

$$\begin{aligned} A = X_0 - (C \sin \zeta + D \sin 2\zeta + E \sin 3\zeta + F \sin 4\zeta) \\ B = K \left[\frac{\dot{X}_0}{K} + \frac{\alpha^2 - \rho^2}{\lambda} + \frac{3(\alpha^2 - \rho^2)^2}{4\lambda^2} + \frac{a^2 \lambda}{\rho^2} + \frac{3\alpha^2 a^2}{2\rho^2} + \frac{19 \lambda^2 a^4}{24 \rho^4} \right] \\ C = -K \left[\frac{2a}{\rho} + \frac{3a(\alpha^2 - \rho^2)}{\lambda \rho} + \frac{5\lambda a^3}{2\rho^3} \right] \\ D = K \left(\frac{a^2}{\rho} \right) \left(1 - \frac{\alpha^2}{4\rho^2} - \frac{\lambda}{6\rho^2} - \frac{\lambda^2 a^2}{4\rho^4} \right) \\ E = \frac{K\lambda a^3}{6\rho^3} \\ F = \frac{K\lambda^2 a^4}{96\rho^5} \end{aligned} \quad (4-70)$$

Terms E and F have been found to be negligible in all cases tested but are included here for the sake of completeness. The constant A is evaluated on the usual assumption that at $\tau = 0$, $X = X_0$.

Solution for Z.- The solution for Z is obtained by replacing the right-hand side of equation (4-34) by the first-order term for Z and the appropriate second-order term for Y to obtain a time-dependent right-hand side. In doing so, of course, terms are carried which are higher than the second order of smallness. If only second-order terms are retained, however, new end conditions corresponding to a and ζ would have to be computed as a peripheral calculation. This calculation is thought to be unnecessary; therefore, equation (4-33) becomes

$$\ddot{Z} + Z = 3(\dot{Z}_0 \sin \tau) \left\{ a \cos(\rho\tau + \zeta) - \frac{\lambda a^2}{2\rho^2} \left[1 - \frac{1}{3} \cos 2(\rho\tau + \zeta) \right] - \frac{\alpha^2}{2\lambda} + \frac{\rho^2}{2\lambda} \right\} \quad (4-71)$$

Let

$$\left. \begin{aligned} -3\dot{Z}_0 \left(\frac{\lambda a^2}{2\rho^2} + \frac{\alpha^2 - \rho^2}{2\lambda} \right) &= \kappa \\ \frac{\lambda a^2 \dot{Z}_0}{2\rho^2} &= \eta \\ 3a\dot{Z}_0 &= \gamma \end{aligned} \right\} \quad (4-72)$$

Then

$$\ddot{Z} + Z = \gamma \cos(\rho\tau + \zeta) \sin \tau + \eta \cos 2(\rho\tau + \zeta) \sin \tau + \kappa \sin \tau \quad (4-73)$$

The solution of this equation is

$$\begin{aligned} Z &= \dot{Z}_0 \sin \tau + \frac{1}{4} \left[\gamma \psi \cos(\rho\tau + \zeta) + \eta \Delta \cos 2(\rho\tau + \zeta) + \kappa \right] \sin \tau \\ &\quad - \frac{1}{2\rho} \left[\gamma \psi \sin(\rho\tau + \zeta) + \frac{\eta \Delta}{2} \sin 2(\rho\tau + \zeta) + \rho C \right] \cos \tau + Z_0 \cos \tau \end{aligned} \quad (4-74)$$

where

$$\left. \begin{aligned} \Delta &= 1 + \rho^2 + \rho^4 \\ \psi &= 1 + \frac{\rho^2}{4} + \frac{\rho^4}{16} \\ C &= -\frac{\gamma \psi}{\rho} \sin \zeta - \frac{\eta \Delta}{2\rho} \sin 2\zeta \end{aligned} \right\} \quad (4-75)$$

In order to make effective use of equation (4-67), it is necessary to compute values for the two integration constants a and ζ . It is found from experience that, when synchronous or very nearly synchronous orbits are under consideration (that is, orbits that return to the same place in space after one complete revolution), one can obtain excellent results by using the values which are obtained from first-order theory. For even moderate departures from the synchronous condition, for instance, on the order of 5° in launch direction, however, this is not the case, especially for ζ . It will therefore be necessary in most cases to evaluate the integration constants. A method for evaluating these constants is outlined in the following.

Differentiating equation (4-67) and applying the initial conditions yields the simultaneous set of transcendental equations

$$Y_0 = a \cos \zeta - \frac{\lambda a^2}{2\rho^2} \left(1 - \frac{1}{3} \cos 2\zeta \right) + \frac{\rho^2 - \alpha^2}{2\lambda} \quad (4-76)$$

$$\dot{Y}_0 = -\rho a \sin \zeta - \frac{\lambda a^2}{3\rho} \sin 2\zeta \quad (4-77)$$

where a and ζ are the two unknowns. These two equations can be solved by eliminating ζ in favor of the two variables u and a where

$$u = a \cos \zeta$$

After substitution and some manipulation,

$$\frac{\lambda u^2}{3\rho^2} + u - \frac{2}{3} \frac{\lambda a^2}{\rho^2} + \frac{\rho^2 - \alpha^2}{2\lambda} = Y_0 \quad (4-78)$$

and

$$\frac{\dot{Y}_0}{\rho} + \left(1 + \frac{2\lambda u}{3\rho^2} \right) \sqrt{a^2 - u^2} = 0 \quad (4-79)$$

Solving this set by eliminating a^2 gives a quartic equation in u

$$\begin{aligned} & \frac{2\lambda^2 u^4}{9\rho^4} - \left(\frac{3}{2} + \frac{\rho^2 + \alpha^2}{3\rho^2} - \frac{2\lambda Y_0}{3\rho^2} \right) u^2 - \left(\frac{5\rho^2 - 2\alpha^2}{2\lambda} - 2Y_0 \right) u \\ & + \frac{3}{4} \frac{\rho^2(\alpha^2 - \rho^2)}{\lambda^2} + \frac{\dot{Y}_0^2}{\rho^2} + \frac{3\rho^2 Y_0}{2\lambda} = 0 \end{aligned} \quad (4-80)$$

In equation (4-80) it can be seen that u is a function of both \dot{Y}_0 and \dot{X}_0 as well as Y_0 (through α , ρ , and λ) instead of just \dot{X}_0 and Y_0 as was the case under first-order theory (eq. (4-42)). As a result, the special case where $u = 0$ will

no longer occur independent of \dot{Y}_0 . It is seen that, when $u = 0$, the following relation is obtained:

$$\frac{3}{4} \frac{\rho^2(\alpha^2 - \rho^2)}{\lambda^2} + \frac{\dot{Y}_0^2}{\rho^2} + \frac{3\rho^2 Y_0}{2\lambda} = 0 \quad (4-81)$$

or

$$\dot{Y}_0 = \pm \sqrt{-\frac{3}{4} \rho^4 \frac{\alpha^2 - \rho^2}{\lambda^2} - \frac{3\rho^4 Y_0}{2\lambda}} \quad (4-82)$$

This relationship is shown in the following sketch for the special case where $Y_0 = 0$. It can be seen that under first-order theory this curve degenerates into a straight vertical line.

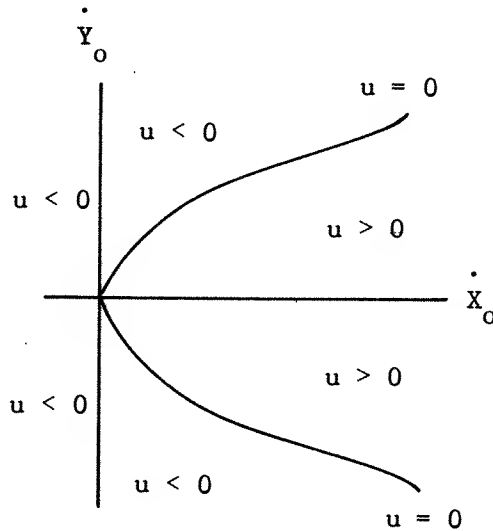

This curve forms the boundary for the selection of the quadrant for ζ since the sign on u along with the positive selection for a determines the sign of $\cos \zeta$. Since the second-order term in equation (4-67) is a function of $\cos 2(\rho\tau + \zeta)$, the quadrant is not ambiguous and all four quadrants must be used. Table 4-II summarizes the second-order sign selection.

TABLE 4-II.- SECOND-ORDER QUADRANT AND SIGN SELECTION

Ejection quadrant	\dot{Y}_0	u	Sign on a	Quadrant for ζ
$0 \leq \phi \leq \pi$	>0	>0	$+$	Fourth
$0 \leq \phi \leq \pi$	>0	<0	$+$	Third
$\pi \leq \phi \leq 2\pi$	<0	<0	$+$	Second
$\pi \leq \phi \leq 2\pi$	<0	>0	$+$	First

It can be seen that an equivalent set of circumstances corresponding to the sketch and table 4-II exists for each initial value of Y_0 . Thus, in order to map out all the possibilities, a series of curves corresponding to $u = 0$ for each value of Y_0 must be computed. This map is done in figure 4-3, for a series of realistic nondimensional values.

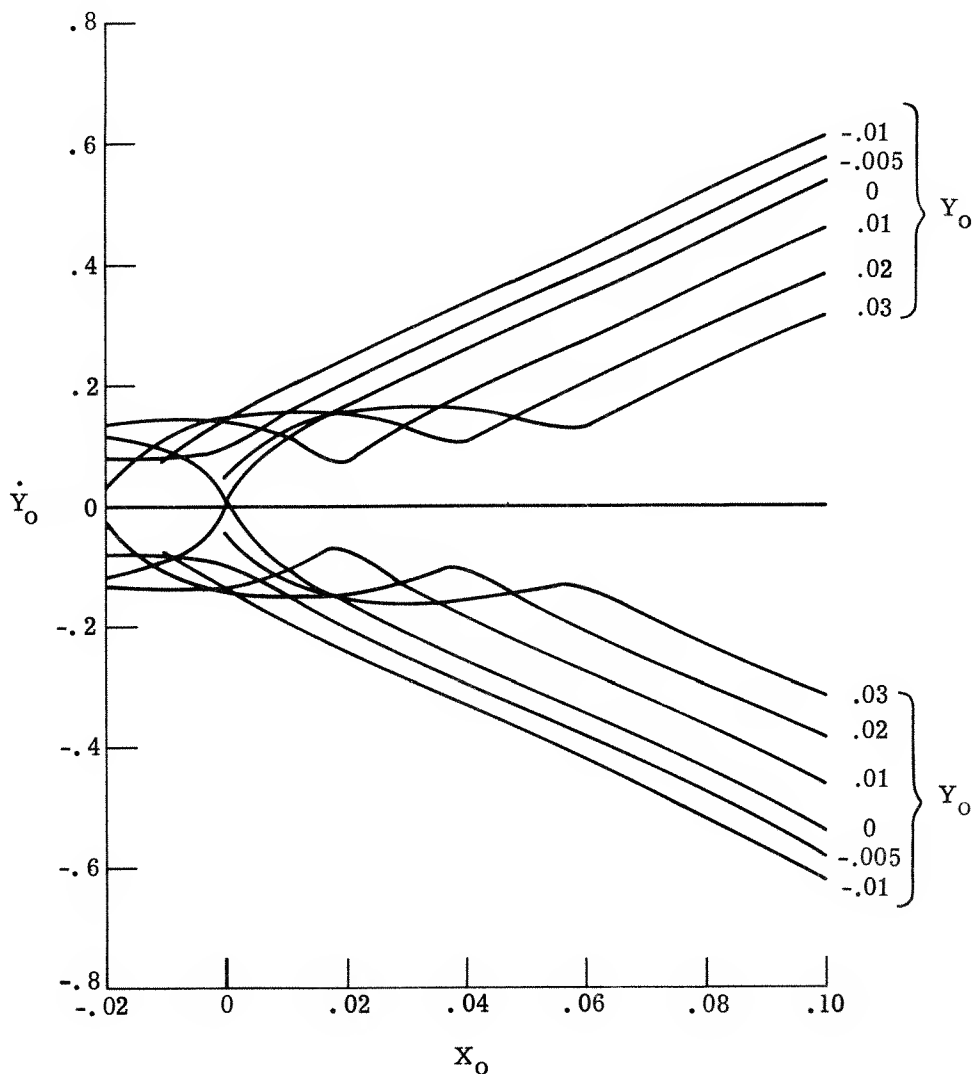

Figure 4-3.- Solutions to equation (4-82) for a series of realistic nondimensional values of X_0 and Y_0 .

In terms of ejection angle ϕ , equation (4-82) becomes

$$\tan \phi = \frac{\dot{Y}_0}{\dot{X}_0} = \pm \sqrt{-\frac{3}{4} \frac{\rho^4 (\alpha^2 - \rho^2)}{\lambda^2 \dot{X}_0^2} - \frac{3\rho^4 Y_0}{2\lambda \dot{X}_0^2}} \quad (4-83)$$

Limitations on the Approximate Solutions

It will be recalled that one of the conditions implicit in solving the equation of an anharmonic oscillator was that $\rho^2 \gg \lambda V$ where V was defined as $V = Y - M$; hence, in order for the solution to be valid,

$$\rho^2 \gg \lambda(Y - M) \tag{4-84}$$

where Y is inherently nondimensionalized in such a way that, for all practical purposes, the term Y in the expression can be neglected. Thus, the criterion which sets a limit on the validity of the solutions in actual practice is

$$\rho^2 \gg -\lambda M \tag{4-85}$$

For synchronous speed at ejection angles between 110° and 250° , equation (4-64) is not satisfied, as can be seen in figure 4-4. Hence, one would not reasonably expect equation (4-67) to describe the physical situation. That this is actually the case can

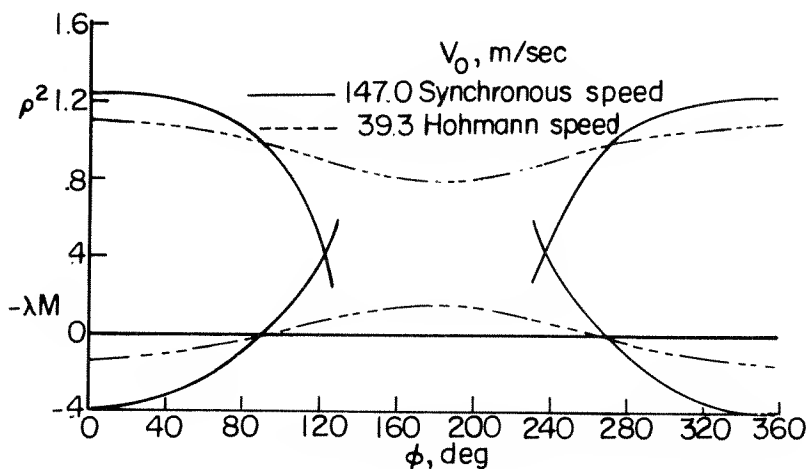

Figure 4-4.- Comparison of the magnitudes of ρ^2 and $-\lambda M$ for Hohmann and synchronous speeds.

be seen by looking ahead to figure 4-11 for ejection angles of 110° and -110° (250°). It is observed that for these cases the error is considerable. At ejection angles of slightly larger magnitude than this value, ρ^2 becomes imaginary ($\rho^2 = \sqrt{4\lambda\beta^2 + \alpha^4}$). Hence, a value for ρ is undefined. Inspection of equation (4-67) shows that ρ is the frequency term; therefore, no solutions would be expected to exist at all with ρ^2 imaginary. This situation occurs for those cases in figure 4-4 for which no solutions are shown. For the Hohmann case (that is, apogee at the altitude of the origin with perigee at some lower altitude) equation (4-67) is satisfied for all ejection angles and ρ^2 remains real; hence, breakdown does not occur (fig. 4-4).

Total-Energy Equation

Equation (4-30) can be integrated exactly. Multiply through by \dot{Y}

$$\dot{Y}\ddot{Y} = \frac{K^2\dot{Y}}{(1+Y)^3} - \frac{\dot{Y}}{(1+Y)^2} \quad (4-86)$$

Then the integral is

$$\frac{\dot{Y}^2}{2} = -\frac{K^2}{2(1+Y)^2} + \frac{1}{1+Y} + \bar{C} \quad (4-87)$$

where \bar{C} is an integration constant.

Rearranging slightly, \bar{C} can be identified as the nondimensionalized total energy (neglecting the out-of-plane term, of course). Hence, replacing K^2 by its equivalent in terms of \dot{X}_0 and Y_0

$$\bar{C} = \frac{1}{2} \left[\dot{Y}^2 + \frac{(1+Y_0)^4 (\dot{X}_0 - 1)^2}{(1+Y)^2} - \frac{2}{1+Y} \right] \quad (4-88)$$

An alternative way to derive equation (4-87) is to change the sign on the potential term in the Lagrangian, equation (4-18), and then substitute the right-hand side of equation (4-22) in this Lagrangian.

Apogee and Perigee Prediction

If, at $\tau = 0$, $Y = Y_0$ and $\dot{Y} = \dot{Y}_0$,

$$\bar{C} = \frac{1}{2} \left[\dot{Y}_0^2 + (\dot{X}_0 - 1)^2 - \frac{2}{1+Y_0} \right] \quad (4-89)$$

and remains constant unless disturbed externally. Then equation (4-87) becomes for subsequent times

$$\dot{Y}^2 = -\frac{K^2}{(1+Y)^2} - \frac{2}{1+Y} + 2\bar{C} \quad (4-87)$$

The extremals are then found to be

$$Y_{\text{extremal}} = \frac{-1 \pm \sqrt{1 + 2(\dot{X}_0 - 1)^2 \bar{C}}}{2\bar{C}} \quad (4-90)$$

The positive value is apogee and the negative value is perigee as measured from orbital altitude.

Solutions in Dimensional Notation

When equations (4-67), (4-69), and (4-74) are converted back to dimensional notation, the following equations result:

$$x = r_s \left[A + B\omega t + C \sin(\rho\omega t + \zeta) + D \sin 2(\rho\omega t + \zeta) + E \sin 3(\rho\omega t + \zeta) + F \sin 4(\rho\omega t + \zeta) \right] \quad (4-91)$$

$$y = r_s \left\{ a \cos(\rho\omega t + \zeta) - \frac{\lambda a^2}{2\rho^2} \left[1 - \frac{1}{3} \cos 2(\rho\omega t + \zeta) \right] - \frac{\alpha^2 - \rho^2}{2\lambda} \right\} \quad (4-92)$$

$$z = r_s \left\{ \frac{\dot{z}_0}{\omega r_s} \sin \omega t + \sin \omega t \left[\frac{\gamma\psi}{4} \cos(\rho\omega t + \zeta) + \frac{\eta\Delta}{4} \cos 2(\rho\omega t + \zeta) + \frac{\kappa}{4} \right] \right. \\ \left. - \cos \omega t \left[\frac{\gamma\psi}{2\rho} \sin(\rho\omega t + \zeta) + \frac{\eta\Delta}{4\rho} \sin 2(\rho\omega t + \zeta) + \frac{\kappa\omega t}{2} + \frac{C}{2} \right] \right\} + \frac{z_0}{r_s} \cos \omega t \quad (4-93)$$

where the constant terms are given by

$$\left. \begin{aligned} K &= \frac{\dot{x}_0}{\omega r_s} - 1 \\ \alpha^2 &= 3K^2 - 2 \\ \beta^2 &= K^2 - 1 \\ \lambda &= -6K^2 + 3 \\ \rho &= (4\lambda\beta^2 + \alpha^4)^{1/4} = (-15K^4 + 24K^2 - 8)^{1/4} \end{aligned} \right\} \quad (4-94)$$

and

$$A = \frac{x_0}{r_s} - (C \sin \zeta + D \sin 2\zeta + E \sin 3\zeta + F \sin 4\zeta) \quad (4-95a)$$

$$B = K \left[\frac{\dot{x}_0}{\omega r_s K} + \frac{\alpha^2 - \rho^2}{\lambda} + \frac{3(\alpha^2 - \rho^2)^2}{4\lambda^2} + \frac{a^2\lambda}{\rho^2} + \frac{3\alpha^2 a^2}{2\rho^2} + \frac{19}{24} \frac{\lambda^2 a^4}{\rho^4} \right] \quad (4-95b)$$

$$C = -K \left[\frac{2a}{\rho} + \frac{3a(\alpha^2 - \rho^2)}{\lambda\rho} + \frac{5\lambda a^3}{2\rho^3} \right] \quad (4-95c)$$

$$D = K \left(\frac{a^2}{\rho} - \frac{a^2\alpha^2}{4\rho^3} - \frac{\lambda\alpha^2}{6\rho^3} - \frac{\lambda^2 a^4}{4\rho^5} \right) \quad (4-95d)$$

$$E = \frac{K\lambda a^3}{6\rho^3} \quad (4-95e)$$

$$F = \frac{K\lambda^2 a^4}{96\rho^5} \quad (4-95f)$$

$$\kappa = \frac{-3\dot{z}_0}{\omega r_s} \left(\frac{\lambda a^2}{2\rho^2} + \frac{\alpha^2 - \rho^2}{2\lambda} \right) \quad (4-95g)$$

$$\eta = \frac{\lambda a^2 \dot{z}_0}{2\omega r_s \rho^2} \quad (4-95h)$$

$$\gamma = \frac{3a\dot{z}_0}{\omega r_s} \quad (4-95i)$$

$$\Delta = 1 + \rho^2 + \rho^4 \quad (4-95j)$$

$$\psi = 1 + \frac{\rho^2}{4} + \frac{\rho^4}{16} \quad (4-95k)$$

$$c = -\frac{\gamma\psi}{\rho} \sin \zeta - \frac{\eta\Delta}{2\rho} \sin 2\zeta \quad (4-95l)$$

Equation (4-80) becomes, in dimensional notation,

$$\begin{aligned} & \frac{2\lambda^2 u^4}{9\rho^4} - \left(\frac{3}{2} + \frac{\rho^2 - \alpha^2}{3\rho^2} - \frac{2\lambda y_0}{3\rho^2 r_s} \right) u^2 - \left(\frac{5\rho^2 - 2\alpha^2}{2\lambda} - \frac{2y_0}{r_s} \right) u \\ & + \frac{3}{4} \frac{\rho^2 (\alpha^2 - \rho^2)}{\lambda^2} + \frac{\dot{y}_0^2}{\rho^2 \omega^2 r_s^2} + \frac{3\rho^2 y_0}{2\lambda r_s} = 0 \end{aligned} \quad (4-96)$$

With equation (4-79) becoming

$$a = \sqrt{\left[\frac{3\rho^2 \dot{y}_0}{\omega r_s (3\rho^2 + 2\lambda u)} \right]^2 + u^2} \quad (4-97)$$

and

$$\zeta = \cos^{-1} \frac{u}{a} \quad (4-98)$$

Equation (4-83) becomes

$$\tan \phi = \frac{\dot{y}_0}{\dot{x}_0} = \pm \sqrt{-\frac{3}{4} \frac{\rho^4 (\alpha^2 - \rho^2) \omega^2 r_s^2}{\lambda^2 \dot{x}_0^2} - \frac{3\rho^4 y_0 \omega^2 r_s}{2\lambda \dot{x}_0^2}} \quad (4-99)$$

The parameters ρ^2 , α^2 , and λ^2 are functions of \dot{x}_0 only; thus the quadrant of ζ changes depending upon launch angle ϕ , but no longer simply at $\pi/2$, π , $3\pi/2$, and 2π as was true for the first-order solutions. Figure 4-5 is a plot of \dot{x}_0 as a function of ϕ for $u = 0$ in dimensional terms which apply to the moon. The

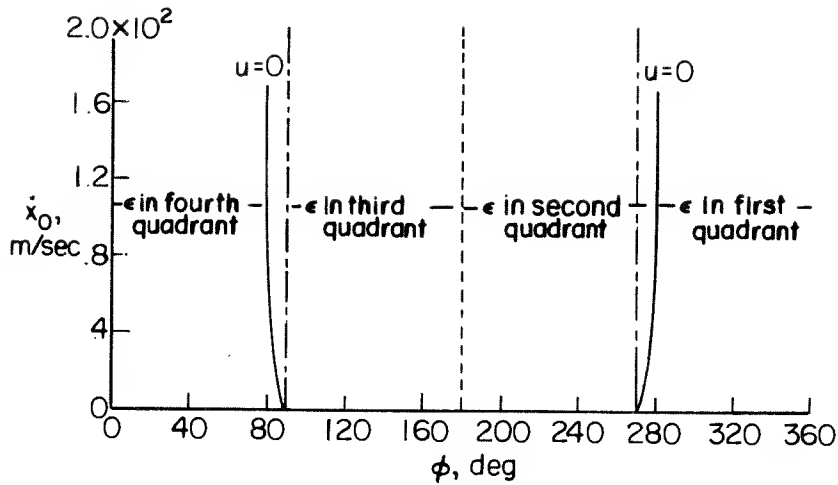

Figure 4-5.- Plot of $u = 0$ as a function of \dot{x}_0 and ejection angle ϕ .

figure can be used, therefore, to determine for the known value of \dot{x}_0 and ϕ , the proper quadrant for ζ . As in first-order theory, a is always selected positive.

Physical Interpretation of Terms

The physical meaning of several of the terms in these solutions can be seen if the first-order solutions and second-order solutions are compared.

y-equation.- The most important equation from a theoretical standpoint is the y-equation. It will be best to begin by comparing equation (4-36) (first-order solution) with equation (4-67) (second-order solution). Thus

$$Y = a' \cos(\alpha\tau + \zeta') + \frac{\beta^2}{\alpha^2} \quad (4-36)$$

as compared to

$$Y = a \cos(\rho\tau + \zeta) - \frac{\lambda a^2}{2\rho^2} \left[1 - \frac{1}{3} \cos 2(\rho\tau + \zeta) \right] - \frac{\alpha^2 - \rho^2}{2\lambda} \quad (4-67)$$

In first-order theory, a sinusoidal term is added to a constant which is a function of initial velocity in the x-direction. Hence, the constant merely reflects a change in energy produced by ejection from the reference orbit and is a function of the speeding up or slowing down of the orbital vehicle's angular rate. Superimposed upon this motion is an oscillatory motion above and below the mean altitude, the maximum amplitudes of which are apogee and perigee. In second-order theory, the same fundamental characteristics appear. In this case, however, they are modified slightly to take better account of the inverse-square nature of the planetary gravity field. The form is essentially the same as first-order theory presents, but the constant term is slightly modified to become the coefficient of the second term combined with the last term on the right in equation (4-67). In like manner, the oscillatory term is present

although the coefficient is changed slightly. Hence, these two terms represent the same type of motion as was present in the first-order theory. Superimposed upon this term is an oscillatory term of twice the frequency of the primary term acting very much as a second harmonic. The primary effect of this term is to increase the apogee and to decrease the perigee. The function of this term is then to take account of the weakening of the restoring force as the gravity field decreases at longer distances from the center of the planet.

Another way of viewing this phenomenon can be seen in figure 4-6 which shows the acceleration of the lander relative to the reference orbit in terms of exact first-order and second-order theory for a typical case. It can be seen that acceleration is

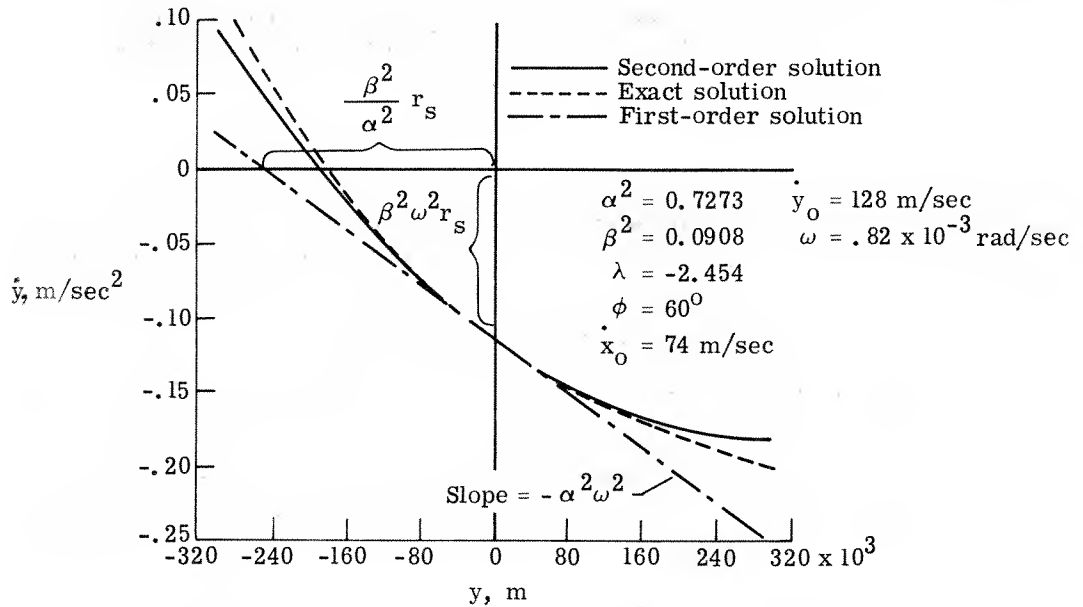
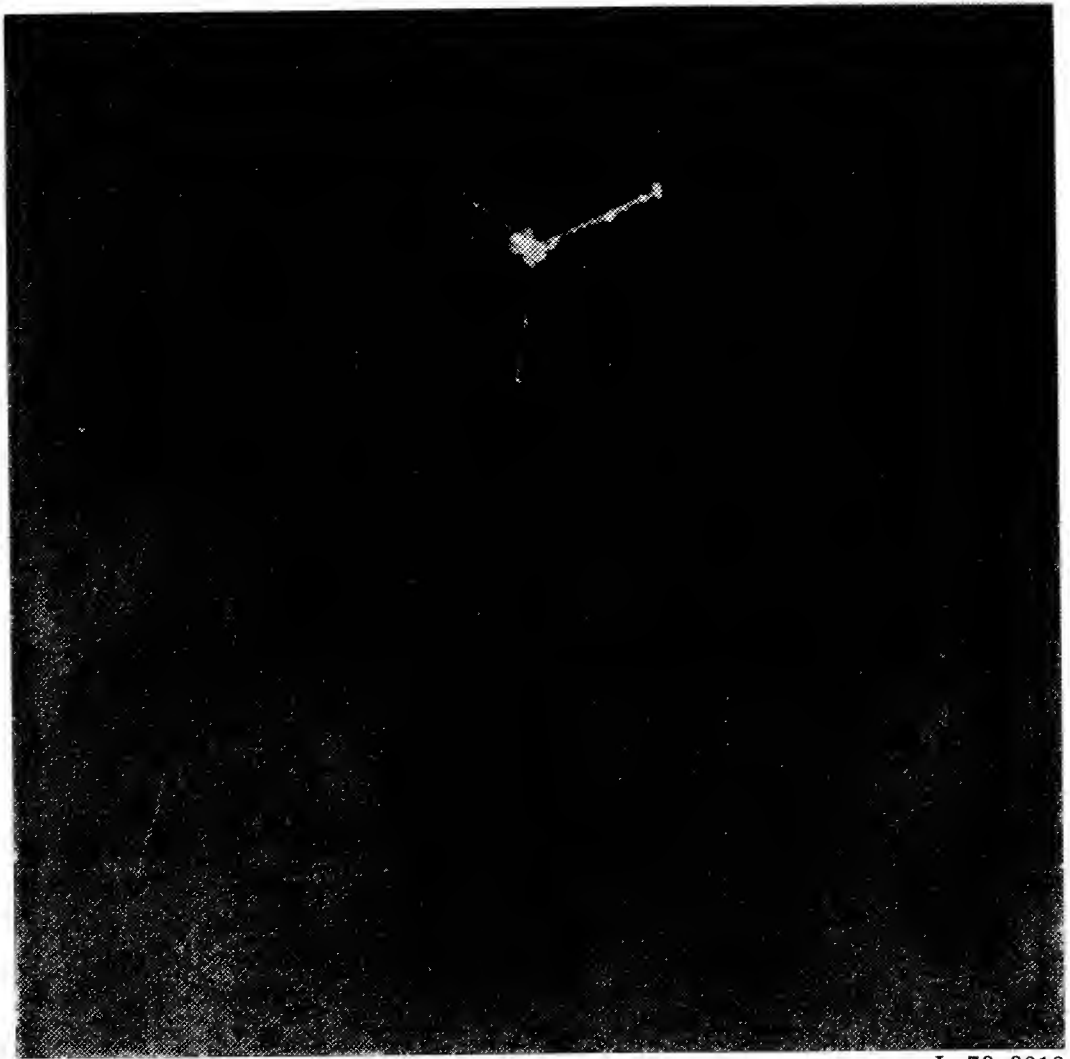

Figure 4-6.- Acceleration of the orbital vehicle as a function of the departure distance from the reference orbit for a typical lunar orbit.

a linear function of displacement over a reasonable altitude range under first-order theory. Under second-order theory, the acceleration is quadratic and forms a much better approximation to the exact conditions. In figure 4-6, β^2/α^2 constitutes a change in mean equilibrium altitude and shows that, in general, the point of equilibrium is displaced, in this case downward. It is pointed out that this change will occur even for orbits of the same total energy as the reference orbit since orbits of the same period but different eccentricity will have a different mean altitude. Under second-order theory this mean displacement is defined a little more precisely by

$$-r_s \left(\frac{\alpha^2 - \rho^2}{2\lambda} + \frac{\lambda a^2}{2\rho^2} \right)$$

(not shown in fig. 4-6). It can be seen that, under the special condition that $\lambda = 0$, this relation reduces to β^2/α^2 as in first-order theory.



L-73-3013

Apollo 15 subsatellite shortly after launch from the Command and Service Module.
This is the first such vehicle to be launched from a spacecraft in lunar orbit.

x-equation.- Comparison of the x-equation, equation (4-69), with first-order theory, equation (4-38), shows the first-order equation contains three main terms: a constant, a secular term, and a sinusoidal term. From the physics of the situation, it is clear that the phenomenon which was manifested as a constant mean separation in the y-equation, equation (4-67), is a time-dependent linear mean-drift rate in the x-equation, equation (4-69). In general, the ejected vehicle would be expected to drift away over an interval of several orbital periods due to its difference in energy and angular momentum. For a synchronous orbit, of course, the coefficient of the secular term would be zero; thus, this term controls the rate of drift.

In other respects the form of this equation is about the same as is obtained for the y-equation, that is, a series of higher-order trigonometric terms.

z-equation.- In the z-equation, first-order theory predicts simple harmonic motion; so again there is a linear restoring force. This theory then assumes that altitude y does not have any appreciable effect upon the out-of-plane mode z . Although in trajectories of practical interest, it is quite true that z does not have any marked effect upon y because the orbits are nearly coplanar, the converse of this statement is not true; and it is found that, for orbits of moderately large eccentricity (for instance, on the order of 0.1), y -coupling into the z -equation can be very significant relative to the total, but admittedly small, amplitude in z . In fact, for the typical synchronous lunar orbit used for the numerical calculations in this book, the coupled term in y and z amounts to one-third of the value of the pure z -term. Consequently, the second-order terms in equation (4-71) represent coupling terms with y .

Test Cases

In order to test the properties of the solutions, the exact differential equations, first-order solution equations, and second-order solution equations have been programmed on a digital computer. The test orbital conditions were taken as those for ejection from a 200-kilometer circular orbit about the moon. The period of the orbit is 7600 seconds. Two particular trajectories are shown in detail. These trajectories were a synchronous orbit and a Hohmann case. Both trajectories had a perigee point 20 kilometers above the surface of the moon. Such orbits are suitable either for reconnaissance or for landing, and both orbits were of interest for the Apollo missions.

Synchronous case.- The chief advantage of selecting the synchronous orbit is that, since it returns to its initial relative position after one revolution, the investigator is in a position to interpret errors in the trajectories in terms of the particular terms in the solutions to which they are due. Such a trajectory is shown as a time history in figure 4-7 and in terms of x and y in figure 4-8. It can be seen that the second-order solutions predict the time of occurrence of periapsis much better than do the first-order solutions.

Ejection is in an upward direction so that apogee is reached at approximately one-quarter orbit and perigee at three-quarters orbit. Time histories showing the main results of this study are shown in figure 4-7. Particular points of interest are

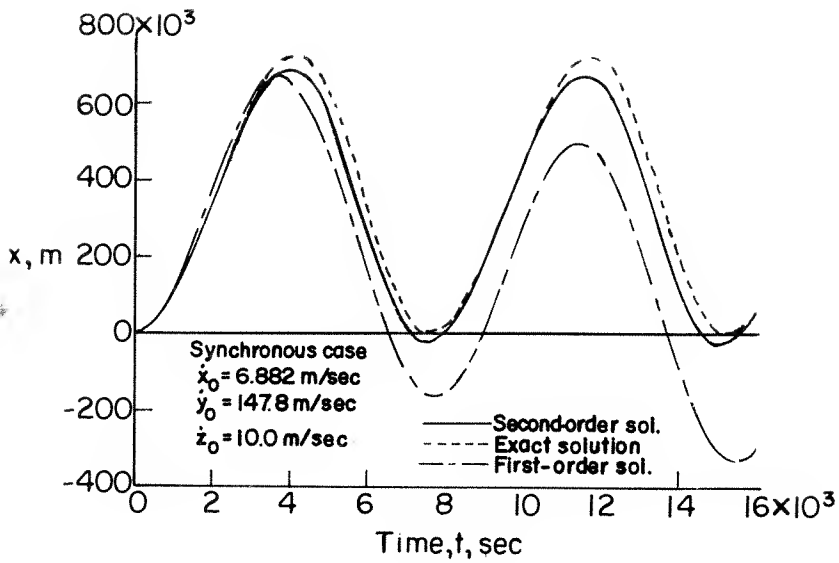

(a) Variation of x with time.

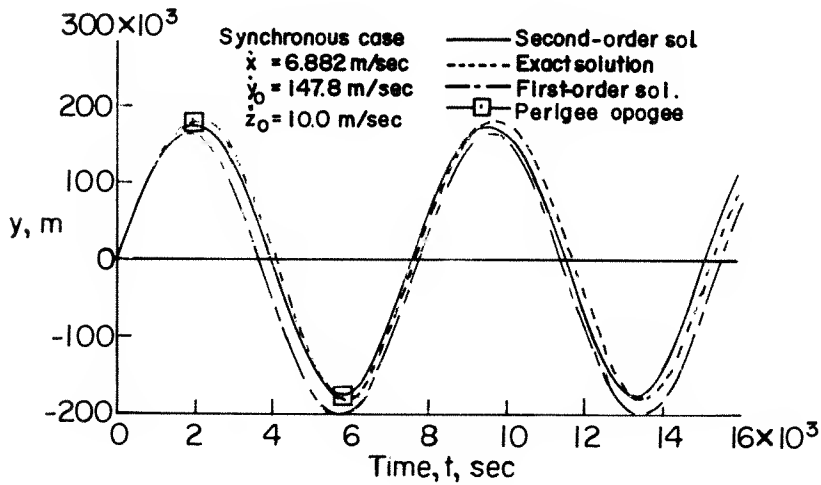

(b) Variation of y with time.

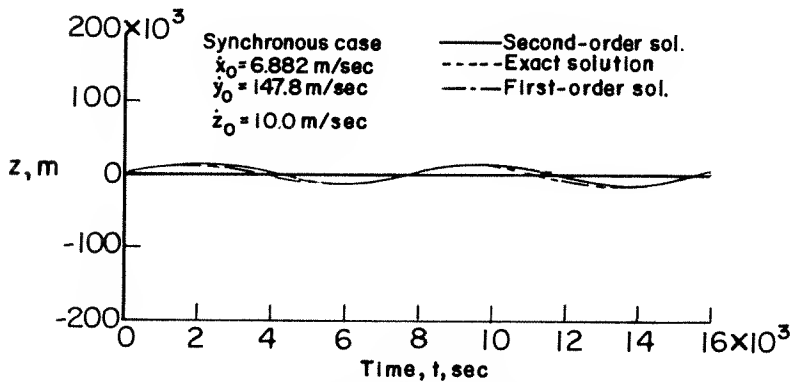

(c) Variation of z with time.

Figure 4-7.- Time history for a 200-kilometer synchronous lunar orbit showing exact, first-order, and second-order solutions.

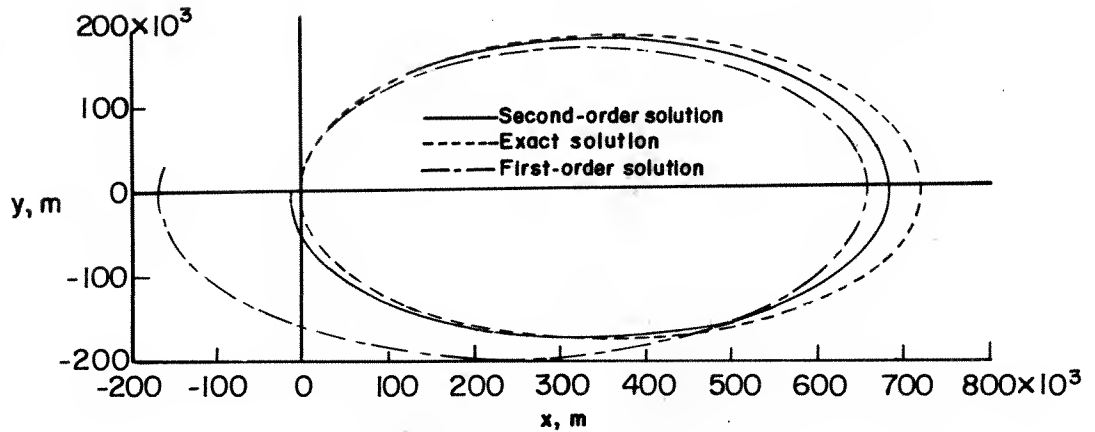

Figure 4-8.- Variation of x with y for a 200-kilometer synchronous lunar orbit showing the respective positions of the orbital vehicle as seen from a vehicle in reference orbit.

(1) The error at perigee in these cases for the second-order solution is 5 kilometers. The second-order solution is, therefore, an improvement over the first-order solution where the error is 20 kilometers and seems to indicate that the equations are indeed useful as a prediction method for lunar landing or reconnaissance vehicles.

(2) The second-order y -equation is in error timewise at the end of one orbit by 200 seconds. Since the period for this orbit is about 6800 seconds, this error is considered to be relatively large. The x -equation is in error timewise by the same amount. The reason for this time error is found in the nature of the anharmonic oscillator equation employed in solving for y . It can be shown that, when the equation is restricted to second-order terms, the period is not a function of amplitude. If terms of higher order had been carried, the period would be a function of amplitude and the time error would be considerably smaller.

Figure 4-8 is a plot of the variation of x with y for the synchronous orbit of figure 4-7. Hence, this figure shows the position of the ejected vehicle as it would be seen from the ejecting vehicle if the out-of-plane motion is disregarded. It is to be observed that, in spite of the time error in both x and y , the spatial agreement between the exact and approximate second-order equations is very good.

Hohmann case.- Figures 4-9 and 4-10 show essentially the same information as figures 4-7 and 4-8, but for the Hohmann case. First-order data have not been included in these cases. The agreement between exact and second-order solutions is better for the y -motion than it is for the synchronous orbit since the ejection velocity here is much smaller. The data were carried for two complete orbits in order to show more clearly the nature of the error buildup which occurs at the end of the first orbit in the x -equation. It is observed that the approximate solution is better over certain portions of the trajectory than over others and that the error is most significant toward the end of each orbital period. This result was also obtained in chapter 3 for a rectangular coordinate system and suggests that the cause of the error is something which is

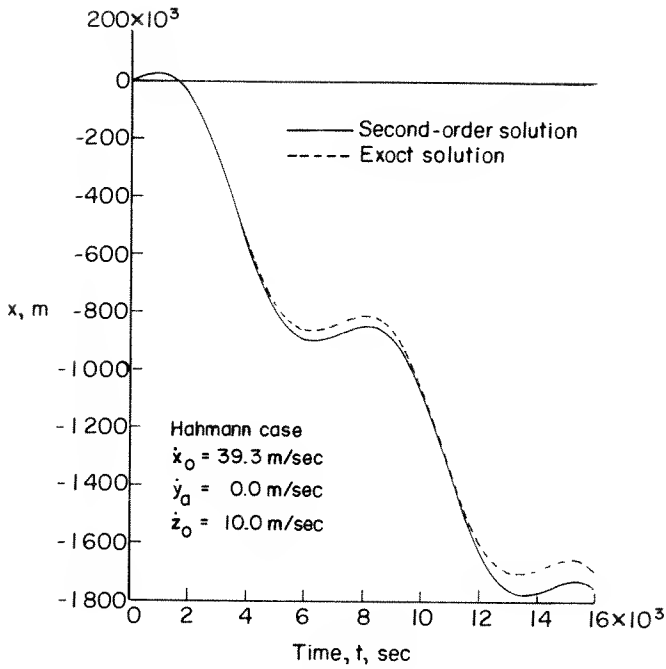

(a) Variation of x with time.

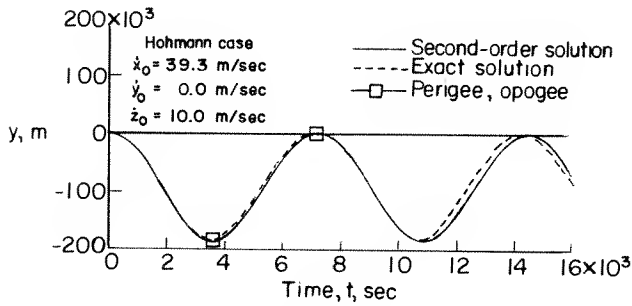

(b) Variation of y with time.

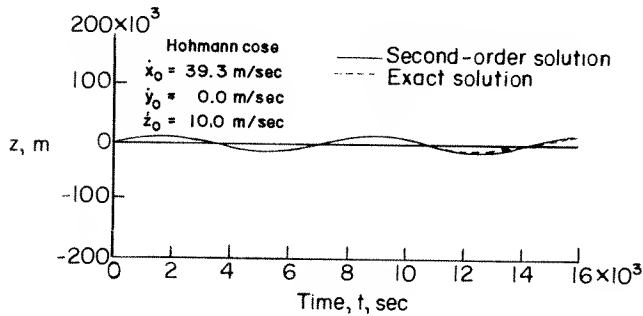

(c) Variation of z with time.

Figure 4-9.- Time history for a 200-kilometer Hohmann transfer to near the lunar surface showing exact and second-order solutions.

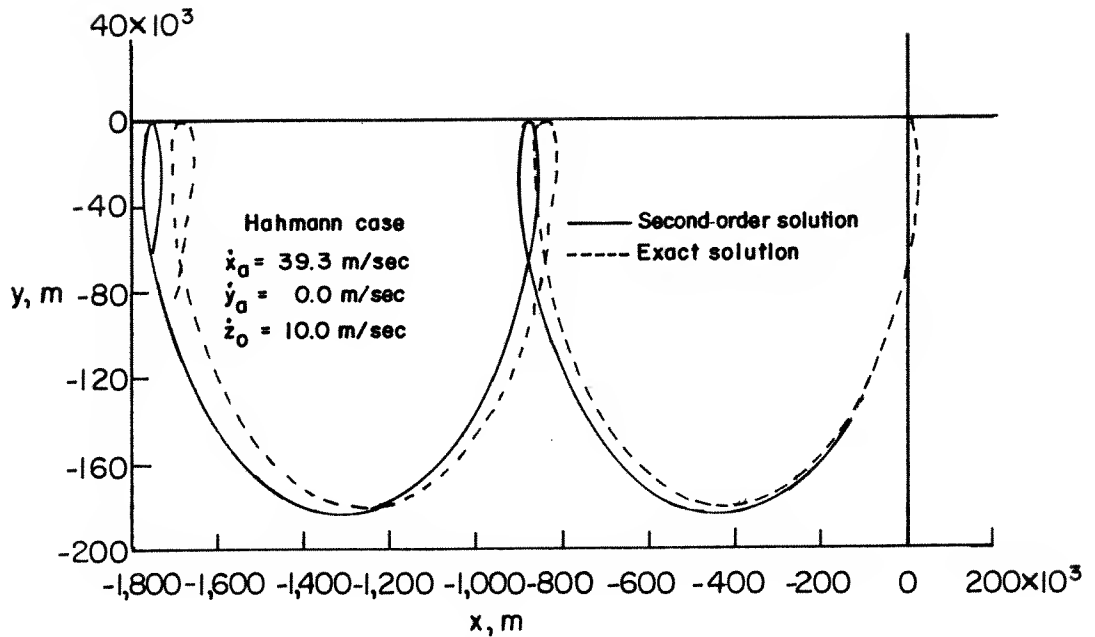

Figure 4-10.- Variation of x with y for a Hohmann transfer from 200-kilometer trajectory showing successive positions of the vehicle as seen by an observer in the orbiting vehicle in the reference orbit.

retained by both approaches. Figure 4-10 shows a gradual departure from the exact solutions for each successive orbit because of the secular term of equation (4-69).

Other launch angles.- In figure 4-11 a series of trajectories is shown for different ejection angles ϕ spaced at 20° intervals. The ejection speed is the same as for a synchronous orbit. None of these are synchronous orbits, however, because of the direction in which ejection takes place. For the sake of clarity, only the exact and second-order solutions are shown.

Figure 4-12 contains the same information as figure 4-9, but the speed is the same as that for a Hohmann transfer. Because of the lower ejection velocity, these trajectories are in much better agreement than those of figure 4-11.

In figure 4-11 no approximate solutions are presented over a range of ejection angles from -120° to $+120^\circ$. In addition, the solutions which are presented for $\pm 110^\circ$ are considerably in error. A fundamental assumption in solving the anharmonic oscillator equation is that the first-order term is large in comparison with the second-order term. For the relatively high ejection speed considered for these cases, the assumption is violated over this range of ejection angles. A similar situation is not encountered for the lower launch speed of figure 4-12. Mathematically, the reason for this difficulty is that for these trajectories ρ^2 becomes progressively small in relation to the second-order term and then imaginary. When ρ^2 is nearly as small as the second-order term, the solutions are in error and, when ρ^2 becomes imaginary, ρ is undefined and no solutions exist at all.

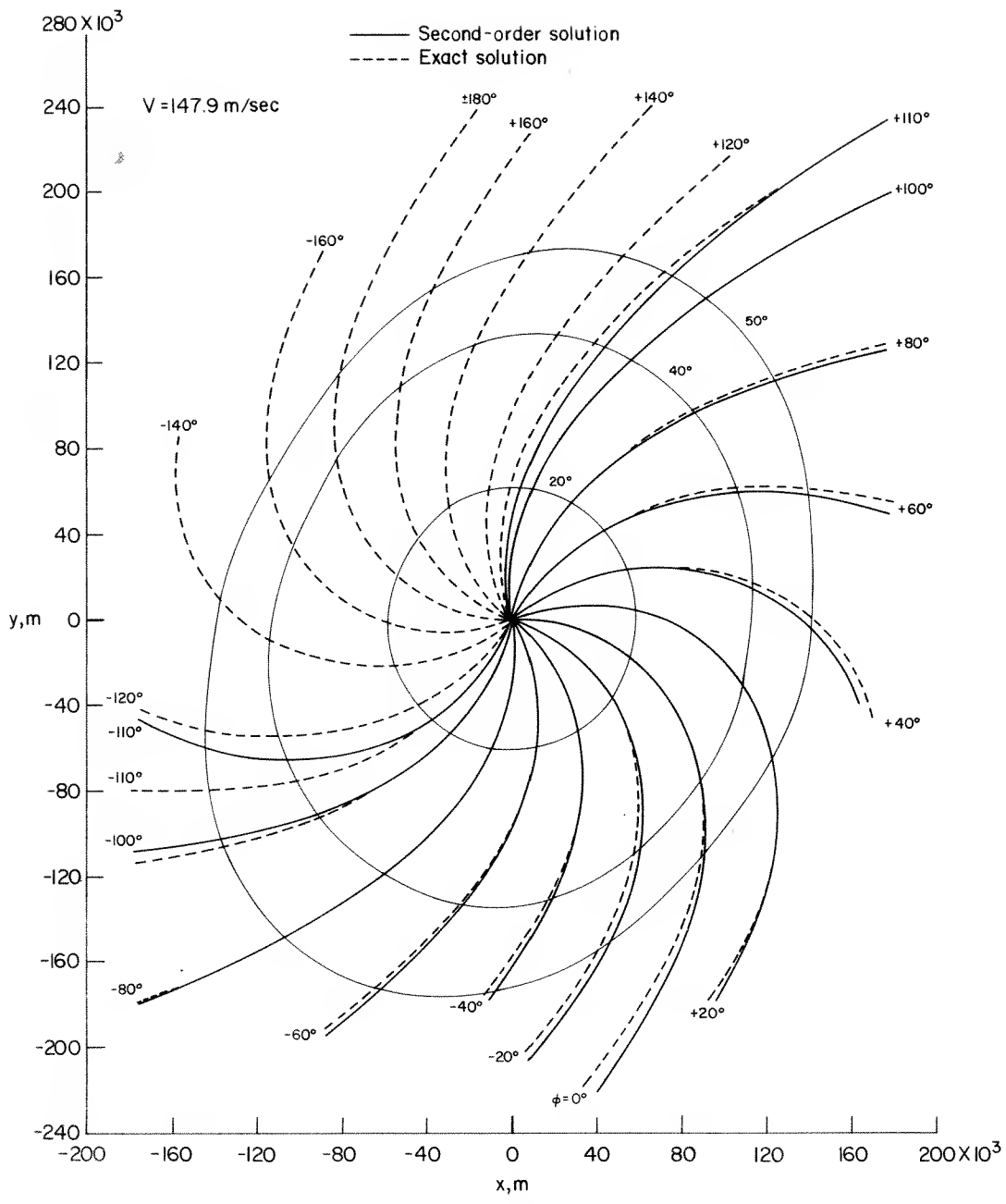

Figure 4-11.- A series of trajectories for different ejection angles ϕ . Ejection speed is the same as for a synchronous transfer to the lunar surface from 200 kilometers altitude.

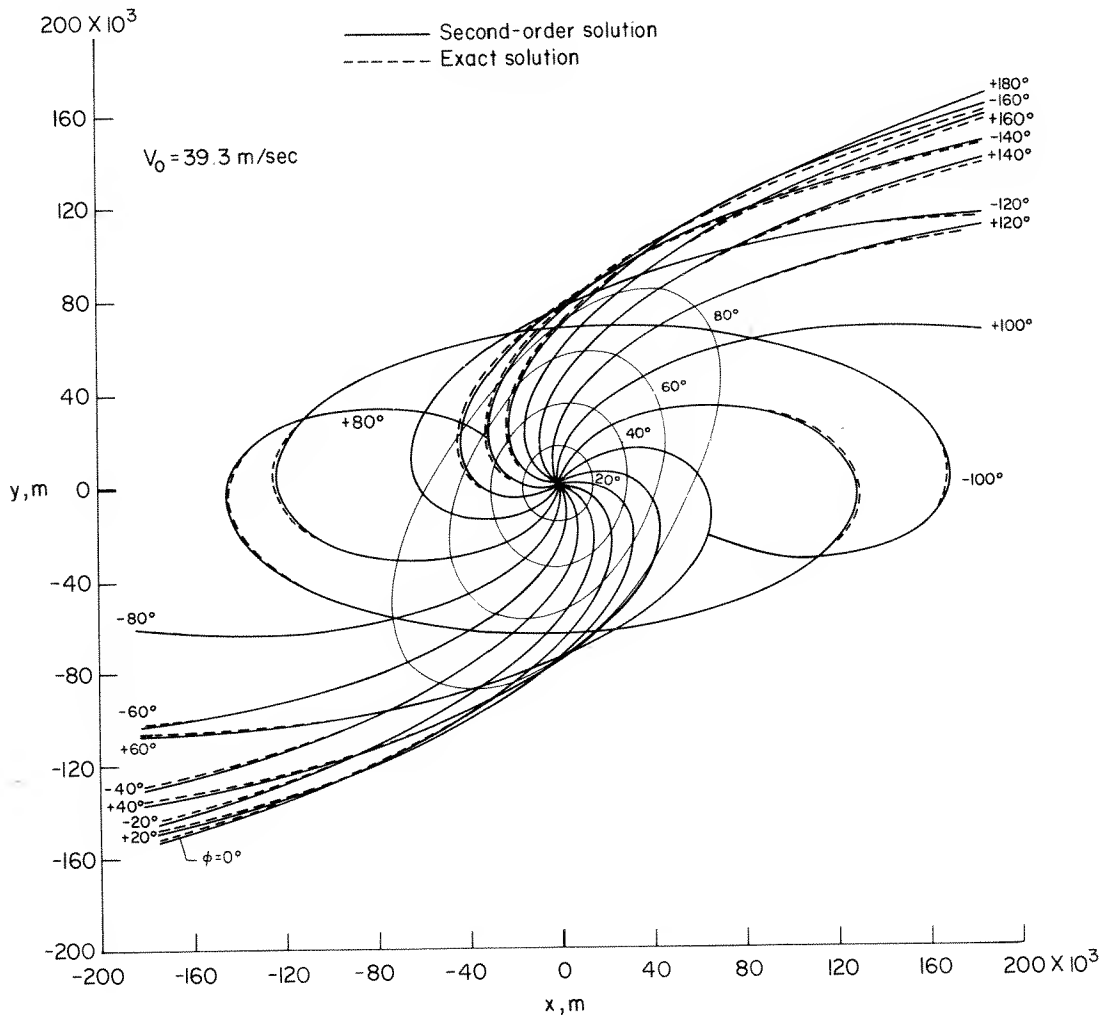
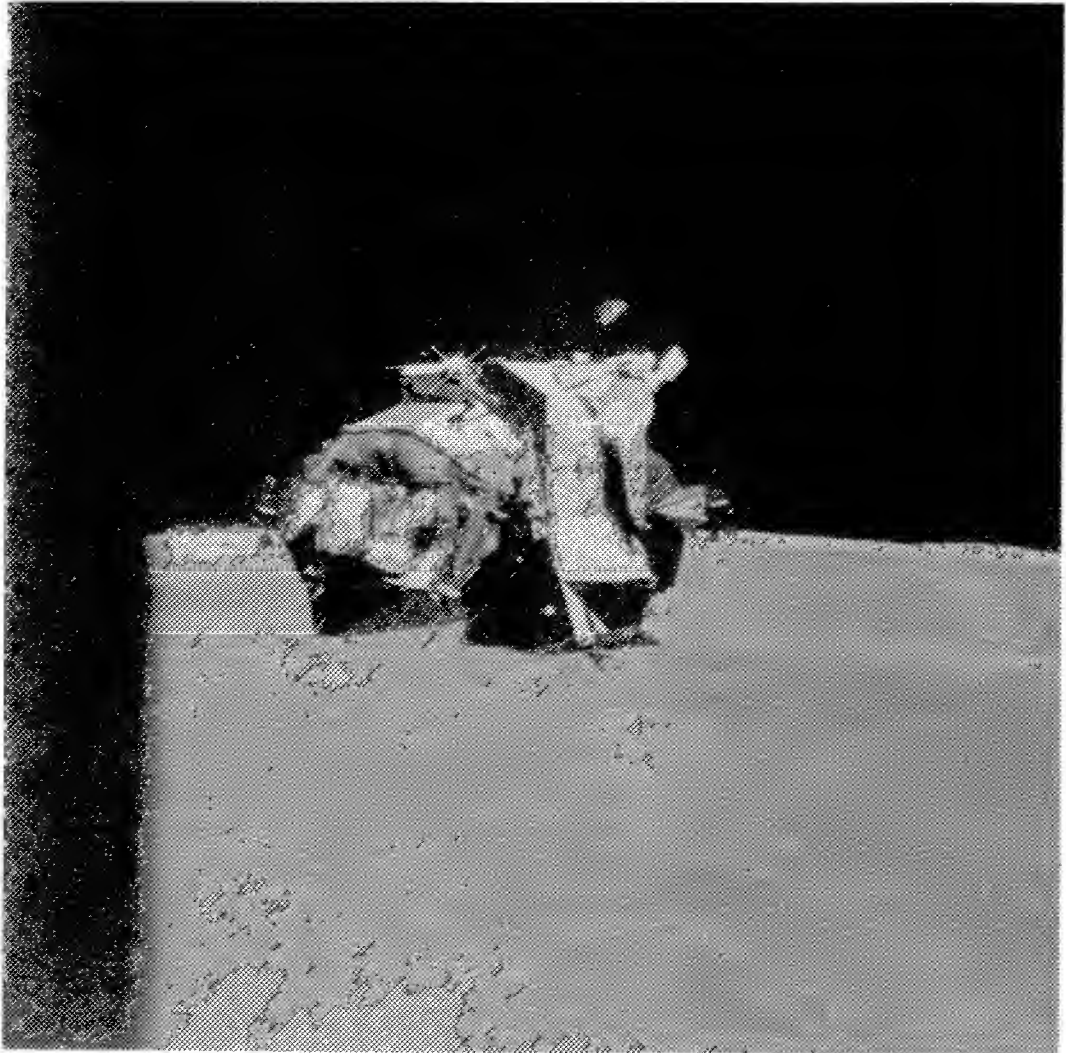

Figure 4-12.- A series of trajectories for different ejection angles ϕ . Ejection speed is the same as for a Hohmann transfer.

Shell-Coordinate Rendezvous Problem

It can easily be seen that the solutions to the relative-motion equations expressed as equations (4-67), (4-68), and (4-74) are so complicated that reversion to a rendezvous set is difficult if not impossible. It can also be seen that, even if such a reversion were analytically available, it would most likely not be useful since at this stage of development the algebraic complexity begins to outweigh any analytical advantages in terms of insight that can be expected. There is, however, a method first suggested by Sparrow and Price (ref. 12) which, while not complete in every detail, is nevertheless highly accurate and useful. The method is based upon a comparison of the motions predicted by the Clohessy-Wiltshire equations with the motions to be expected if both target and rendezvous vehicles are in circular orbits. Since these orbits can be defined exactly, it seems logical to compare the exact and approximate results and hence to determine just what part of the equations is necessary to define circular trajectories.



L-73-3014

Apollo 16 ascent stage above the moon as it approaches the
Command and Service Module during rendezvous.

In this manner a correction factor can be determined which, when added to the conventional Clohessy-Whitshire set, gives a broad range of accurate applicability. In order to keep this problem as simple as possible, it is advantageous to follow the original paper and keep the development planar from the beginning. Hence, in what follows, the z-coordinate will be neglected with respect to the x- and y-coordinates.

If equations (4-19) and (4-20) are expanded in the gravity field and only terms of the first order are retained, then the following equations result:

$$m\ddot{x} - 2m\omega\dot{y} = 0 \quad (4-100)$$

$$m\ddot{y} + 2m\omega\dot{x} - 3m\omega^2 y = 0 \quad (4-101)$$

It can be seen that these are exactly the same equations as (3-26) and (3-27), except that in this case the coordinate system is a shell coordinate system rather than a rectangular one. Hence, the solutions are the same, namely

$$\begin{aligned} \frac{x}{r_s} = & 2\left(\frac{2\dot{x}_0}{\omega r_s} - \frac{3y_0}{r_s}\right)\sin \omega t - \frac{2\dot{y}_0}{\omega r_s} \cos \omega t + \left(\frac{6y_0}{r_s} - \frac{3\dot{x}_0}{\omega r_s}\right)\omega t \\ & + 2\frac{\dot{y}_0}{\omega r_s} + \frac{x_0}{r_s} + q_x \end{aligned} \quad (4-102)$$

and

$$\frac{y}{r_s} = \left(\frac{2\dot{x}_0}{\omega r_s} - \frac{3y_0}{r_s}\right)\cos \omega t + \frac{\dot{y}_0}{\omega r_s} \sin \omega t + \frac{4y_0}{r_s} - \frac{2\dot{x}_0}{\omega r_s} + q_y \quad (4-103)$$

where q_x and q_y represent the aggregate of all higher-order terms in the x- and y-equations, respectively. Equation (4-22) is, however, an exact relation and, if both target and rendezvous vehicles are in circular orbits, y is a constant (the altitude difference between the orbits) and equation (4-22) becomes

$$\left(\frac{\dot{x}}{\omega r_s} - 1\right)\left(1 + \frac{y_0}{r_s}\right)^2 = K \quad (4-104)$$

This equation can also be solved for \dot{x} yielding the exact expression for circular orbits. If at $t = 0$, $\dot{x} = \dot{x}_0$ and y_0 is a constant, K is given by

$$K = \left(\frac{\dot{x}_0}{\omega r_s} - 1\right)\left(1 + \frac{y_0}{r_s}\right)^2 \quad (4-105)$$

Then equation (4-104) reduces by cancellation to

$$\frac{\dot{x}}{\omega r_s} = \frac{\dot{x}_0}{\omega r_s} \quad (4-106)$$

With ω canceled this equation integrates directly to

$$\frac{x}{r_s} = \frac{\dot{x}_0}{r_s} t + \text{Constant}$$

or if, at $t = 0$, $\dot{x} = \dot{x}_0$, the constant can be determined and

$$\frac{x}{r_s} = \frac{\dot{x}_0 t}{r_s} + \frac{x_0}{r_s} \quad (4-107)$$

The physical explanation for this equation is quite simple. If the difference in orbital altitude is held constant, the separation of the vehicles depends solely on the difference in their angular rates. This is precisely what \dot{x}_0/r_s is physically; so the separation angle is strictly a linear function of time and depends on the initial angular separation as an epoch angle. A comparison of equations (4-102) and (4-106) shows that for the special case of circular orbits

$$q_x = -2 \left(\frac{2\dot{x}_0}{\omega r_s} - \frac{3y_0}{r_s} \right) \sin \omega t + \frac{2\dot{y}_0}{\omega r_s} \cos \omega t - \left(\frac{6y_0}{r_s} - \frac{3\dot{x}_0}{\omega r_s} \right) \omega t - 2 \frac{\dot{y}_0}{\omega r_s} \quad (4-108)$$

However, since q_x is a small correction factor in equation (4-102), it will be sufficient to drop the smaller parts of q_x . For nearly circular orbits obviously $\dot{y}_0 \approx 0$ and for small values of ωt will practically cancel anyway. Hence,

$$q_x \approx -2 \left(\frac{2\dot{x}_0}{\omega r_s} - \frac{3y_0}{r_s} \right) \sin \omega t - \left(\frac{6y_0}{r_s} - \frac{4\dot{x}_0}{\omega r_s} \right) \omega t = 4 \left(\frac{3}{2} \frac{y_0}{r_s} - \frac{\dot{x}_0}{\omega r_s} \right) (\sin \omega t - \omega t) \quad (4-109)$$

If in equation (4-23), \ddot{y} and z are set equal to zero and the equation is solved for $\dot{x}/\omega r_s$, one obtains for a circular orbit with fixed y_0

$$\frac{\dot{x}_0}{\omega r_s} = 1 - \left(1 + \frac{y_0}{r_s} \right)^{-3/2} \quad (4-110)$$

Then substituting this value back into equation (4-109) for $\dot{x}_0/\omega r_s$ the correction factor for the x-equation is found to be approximately

$$q_x = 4 \left[\frac{3}{2} \frac{y_0}{r_s} - 1 + \left(1 + \frac{y_0}{r_s} \right)^{-3/2} \right] (\sin \omega t - \omega t) \quad (4-111)$$

It is convenient to write this equation in the functional form

$$q_x = 4Q(y_0)(\sin \omega t - \omega t) \quad (4-112)$$

where

$$Q(y_0) = \frac{3}{2} \frac{y_0}{r_s} - 1 + \left(1 + \frac{y_0}{r_s} \right)^{-3/2} \quad (4-113)$$

will be referred to as the "Sparrow Q factor."

In the y-direction the same situation is obtained. If both orbits are circular,

$$\frac{y}{r_s} = \frac{y_0}{r_s} = \text{Constant} \quad (4-114)$$

Then a comparison of equation (4-114) with equation (4-103) shows that

$$q_y = -\left(\frac{2\dot{x}_0}{\omega r_s} - \frac{3y_0}{r_s}\right) \cos \omega t - \frac{\dot{y}_0}{\omega r_s} \sin \omega t + \frac{2\dot{x}_0}{\omega r_s} - \frac{3y_0}{r_s} \quad (4-115)$$

As before, the term in \dot{y}_0 is assumed to be negligible and hence vanishes. Then

$$q_y = -2\left(\frac{3}{2} \frac{y_0}{r_s} - \frac{\dot{x}_0}{\omega r_s}\right) (1 - \cos \omega t) \quad (4-116)$$

or by use of equations (4-113) and (4-110)

$$q_y = -2Q(y_0)(1 - \cos \omega t) \quad (4-117)$$

With these correction factors the first-order Clohessy-Wiltshire equations can be upgraded in the case of planar motion to the form

$$\begin{aligned} \frac{x}{r_s} = & 2\left(\frac{2\dot{x}_0}{\omega r_s} - \frac{3y_0}{r_s}\right) \sin \omega t - 2\frac{\dot{y}_0}{\omega r_s} \cos \omega t + \left(6\frac{y_0}{r_s} - \frac{3\dot{x}_0}{\omega r_s}\right) \omega t \\ & + 2\frac{\dot{y}_0}{\omega r_s} + \frac{x_0}{r_s} + 4Q(y_0)(\sin \omega t - \omega t) \end{aligned} \quad (4-118)$$

$$\begin{aligned} \frac{y}{r_s} = & \left(\frac{2\dot{x}_0}{\omega r_s} - \frac{3y_0}{r_s}\right) \cos \omega t + \frac{\dot{y}_0}{\omega r_s} \sin \omega t + \frac{4y_0}{r_s} - \frac{2\dot{x}_0}{\omega r_s} \\ & - 2Q(y_0)(1 - \cos \omega t) \end{aligned} \quad (4-119)$$

With considerable cancellation in the Q terms, these equations lead to the equivalent equations

$$\frac{x}{r_s} = \frac{\dot{x}_0}{\omega r_s} \omega t + \frac{x_0}{r_s} + \frac{2\dot{y}_0}{\omega r_s} (1 - \cos \omega t) \quad (4-120)$$

$$\frac{y}{r_s} = \frac{y_0}{r_s} + \frac{\dot{y}_0}{\omega r_s} \sin \omega t \quad (4-121)$$

If it is desired to achieve interception at some time τ_1 , set x and y equal to zero and solve for the velocity needed to achieve these conditions. When this procedure is followed, \dot{x}_c as a function of τ_1 can be expressed as

$$\frac{\dot{x}_c}{\omega r_s} = -\frac{x_0 \sin \omega \tau_1 + 2y_0 (1 - \cos \omega \tau_1)}{r_s \omega \tau_1 \sin \omega \tau_1} \quad (4-122)$$

and \dot{y}_c can be expressed as

$$\frac{\dot{y}_c}{\omega r_s} = - \frac{y_0}{r_s \sin \omega \tau_1} \quad (4-123)$$

Equations of Sparrow and Price

An alternative guidance-equation set is obtained if $Q(y_0)$ is retained in the form of equation (4-113). In this case, the cancellation between equations (4-118) and (4-120), and that between equations (4-119) and (4-121) does not occur so extensively, and one can obtain guidance equations by setting x in equation (4-118) and y in equation (4-119) equal to zero and solving for the conditions needed to rendezvous in some specified time τ_1 . The set which results is analogous to equations (4-122) and (4-123) except, however, that in this case the resultant equations can be expressed as the Clohessy-Wiltshire equations with an additional correction factor.

In equation (4-118) set the left-hand side equal to zero and multiply through by $\sin \omega \tau_1$. In equation (4-119) set the left-hand side equal to zero and multiply through by $2(1 - \cos \omega \tau_1)$. Then add the two equations to get

$$\begin{aligned} \frac{\dot{x}_c}{\omega r_s} = \frac{1}{\Lambda} \left[\frac{x_0}{r_s} \sin \omega \tau_1 + \frac{y_0}{r_s} 6(\omega \tau_1 \sin \omega \tau_1 - 14 + 14 \cos \omega \tau_1) \right] \\ - \frac{Q(y_0)}{\Lambda} (\omega \tau_1 + \Lambda) \end{aligned} \quad (4-124)$$

where Λ is given by equation (4-10)

$$\Lambda = 3\omega \tau_1 \sin \omega \tau_1 - 8(1 - \cos \omega \tau_1) \quad (4-10)$$

Then substitute the right-hand side of equation (4-124) in equation (4-119) for \dot{x}_0 , again with the left-hand side set equal to zero, to get

$$\begin{aligned} \frac{\dot{y}_c}{\omega r_s} = \frac{1}{\Lambda} \left[-2 \frac{x_0}{r_s} (1 - \cos \omega \tau_1) + \frac{y_0}{r_s} 4(\sin \omega \tau_1 - 3\omega \tau_1) \right] \\ - \frac{Q(y_0)}{4\Lambda} (\Lambda - 3\omega \tau_1 \sin \omega \tau_1) \omega \tau_1 \end{aligned} \quad (4-125)$$

These (equations (4-124) and (4-125)) are the rendezvous equations of Sparrow and Price (ref. 12). It is of some importance to understand the basic physical assumptions under which these equations were derived. Particularly, they were derived under the assumption that in the Q term \dot{y}_0 is zero. This assumption is not very disadvantageous for real orbits where both rendezvous and target vehicles are in nearly circular orbits. Except for this assumption, the equations are found to work extremely well so long as both bodies are in the same orbit plane. It is also useful to note that the Q -equation (equation (4-113)), degenerates to zero near the target in equa-

tions (4-124) and (4-125), thus reducing these equations to the linearized Clohessy-Wiltshire form.

These equations have been tested extensively and have been found to be the best purely analytical solutions so far published. The assumptions in the derivation, however, do include neglecting secular terms. Thus, these equations will eventually break down, and they should be used with caution when rendezvous is to be attempted over a long period of time including several orbital periods.

CHAPTER 5
DYNAMICS OF CONNECTED-POINT MASSES

DYNAMICS OF CONNECTED-POINT MASSES

In chapter 1 the motion of a point mass in orbit was discussed. In chapters 3 and 4 the relative motion of two point masses was considered in some detail. A logical extension of this development is to consider two point masses which are held a fixed distance from each other, creating a dumbbell structure. Such a dumbbell in orbit under the influence of a gravity field will be studied in this chapter. This dumbbell will then be connected at its center of mass to a second dumbbell through a torquing gimbal system. It is hoped that in this manner a simple mathematical model can be developed which will allow an analytic treatment with a minimum number of approximations and which will exhibit the effects of both gravity gradients and gyroscopic moments. This development is intended to provide a base point for more complicated analyses.

Since the dimensions of realistic space vehicles are small in comparison with separation distances which have been under discussion in chapters 3 and 4, sufficient accuracy for this analysis can be attained by using rectangular coordinates. One dumbbell will be assumed to be small and spinning rapidly, thus simulating a gyroscope. The other dumbbell is assumed to be moving slowly and thus simulates the characteristics of a cylindrical space station.

The equations of motion will be found from the Lagrangian subject to the appropriate constraints and then simplified where dropping small terms is appropriate. A transformation will then be made on the smaller dumbbell transforming this equation to a system more natural to classical gyroscope spin by assuming that precession and nutation are slow phenomena.

Moments Acting on a Simple Dumbbell in a Right-Handed, Moving,
Rectangular Coordinate System

The Lagrangian for a single dumbbell in a right-handed, moving rectangular coordinate system in a circular orbit is

$$L = \frac{1}{2} m (\dot{x}^2 + \dot{y}^2 + \dot{z}^2) - m\omega \left[\dot{x}(y + r_s) - x\dot{y} \right] + \frac{1}{2} m\omega^2 \left[(y + r_s)^2 + x^2 \right] + \frac{m g_e r_e^2}{\left[x^2 + (y + r_s)^2 + z^2 \right]^{1/2}} - \lambda m\omega^2 (x^2 + y^2 + z^2) \quad (5-1)$$

It can be seen that this equation is the same as equation (3-8) with \dot{r}_s set equal to zero except for the Lagrange multiplier in the last term on the right which acts as a constraint on the distance from the center of mass. Except for these changes the assumptions are also the same as in equation (3-8), namely, an inverse-

square gravity field for a spherical earth with point masses in orbit. In this case it is assumed that both point masses are identical and that motion about the common center of mass for the two ends of the dumbbell is uncoupled from the orbital motion of the center of mass. The constraint specifies that each individual mass is some fixed distance ρ from the common center of mass with ρ^2 held constant. Thus equation (5-1) must be satisfied subject to a constraint (ref. 13) expressed by λ , the solution for which will allow specification of the tension or compression in the member connecting the point masses.

With the semilength of the dumbbell given by

$$\rho^2 = x^2 + y^2 + z^2 \quad (5-2)$$

the equations of motion become

$$\left. \begin{aligned} m\ddot{x} - 2m\dot{y}\omega - m\dot{x}\omega^2 + \frac{mg_e r_e^2 x}{[x^2 + (y + r_s)^2 + z^2]^{3/2}} - 2\lambda m\omega^2 x &= 0 \\ m\ddot{y} + 2m\dot{x}\omega - m(y + r_s)\omega^2 + \frac{mg_e r_e^2 (y + r_s)}{[x^2 + (y + r_s)^2 + z^2]^{3/2}} - 2\lambda m\omega^2 y &= 0 \\ m\ddot{z} + \frac{mg_e r_e^2 z}{[x^2 + (y + r_s)^2 + z^2]^{3/2}} - 2\lambda m\omega^2 z &= 0 \end{aligned} \right\} \quad (5-3)$$

In order to nondimensionalize the foregoing equations for convenience in handling, divide through by $\omega^2 r_s$ which yields

$$\left. \begin{aligned} \frac{m\ddot{x}}{\omega^2 r_s} - \frac{2m\dot{y}}{\omega r_s} - \frac{m\dot{x}}{r_s} + \frac{mg_e r_e^2}{\omega^2 r_s^3} \frac{x/r_s}{\left[\left(\frac{x}{r_s}\right)^2 + \left(1 + \frac{y}{r_s}\right)^2 + \left(\frac{z}{r_s}\right)^2\right]^{3/2}} - 2\lambda \frac{m\dot{x}}{r_s} &= 0 \\ \frac{m\ddot{y}}{\omega^2 r_s} + \frac{2m\dot{x}}{\omega r_s} - m\left(1 + \frac{y}{r_s}\right) + \frac{mg_e r_e^2}{\omega^2 r_s^3} \frac{1 + \frac{y}{r_s}}{\left[\left(\frac{x}{r_s}\right)^2 + \left(1 + \frac{y}{r_s}\right)^2 + \left(\frac{z}{r_s}\right)^2\right]^{3/2}} - 2\lambda \frac{m\dot{y}}{r_s} &= 0 \\ \frac{m\ddot{z}}{\omega^2 r_s} + \frac{mg_e r_e^2}{\omega^2 r_s^3} \frac{z/r_s}{\left[\left(\frac{x}{r_s}\right)^2 + \left(1 + \frac{y}{r_s}\right)^2 + \left(\frac{z}{r_s}\right)^2\right]^{3/2}} - 2\lambda m \frac{z}{r_s} &= 0 \end{aligned} \right\} \quad (5-4)$$

Now $\omega^2 = \frac{g_e r_e^2}{r_s^3}$ for one orbit, and so the system can be nondimensionalized in the normal way for orbits yielding (dropping the unnecessary m)

$$\left. \begin{aligned} \ddot{X} - 2\dot{Y} - X + X[X^2 + (1+Y)^2 + Z^2]^{-3/2} - 2\lambda X &= 0 \\ \ddot{Y} + 2\dot{X} - (1+Y) + (1+Y)[X^2 + (1+Y)^2 + Z^2]^{-3/2} - 2\lambda Y &= 0 \\ \ddot{Z} + Z[X^2 + (1+Y)^2 + Z^2]^{-3/2} - 2\lambda Z &= 0 \end{aligned} \right\} \quad (5-5)$$

with ρ^2 in equation (5-2) nondimensionalized to the form

$$P^2 = X^2 + Y^2 + Z^2 = \text{Constant} \quad (5-6)$$

Transposing so as to have only the acceleration terms on the left

$$\left. \begin{aligned} \ddot{X} &= 2\dot{Y} + X - X[X^2 + (1+Y)^2 + Z^2]^{-3/2} + 2\lambda X \\ \ddot{Y} &= -2\dot{X} + (1+Y) - (1+Y)[X^2 + (1+Y)^2 + Z^2]^{-3/2} + 2\lambda Y \\ \ddot{Z} &= -Z[X^2 + (1+Y)^2 + Z^2]^{-3/2} + 2\lambda Z \end{aligned} \right\} \quad (5-7)$$

The exact moments become

(1) In pitch

$$\begin{aligned} \overline{M}_{\text{pitch}} &= m(X\ddot{Y} - Y\ddot{X}) \\ &= m \left\{ -2X\dot{X} + X(1+Y) - X(1+Y)[X^2 + (1+Y)^2 + Z^2]^{-3/2} \right. \\ &\quad \left. - 2Y\dot{Y} - XY + XY[X^2 + (1+Y)^2 + Z^2]^{-3/2} \right\} \end{aligned} \quad (5-8)$$

(2) In roll

$$\begin{aligned} \overline{M}_{\text{roll}} &= m(Y\ddot{Z} - Z\ddot{Y}) \\ &= m \left\{ -YZ[X^2 + (1+Y)^2 + Z^2]^{-3/2} + 2\dot{X}Z - Z(1+Y) \right. \\ &\quad \left. + Z(1+Y)[X^2 + (1+Y)^2 + Z^2]^{-3/2} \right\} \end{aligned} \quad (5-9)$$

(3) In yaw

$$\begin{aligned}\bar{M}_{\text{yaw}} &= m(\ddot{XZ} - Z\ddot{X}) \\ &= m\left\{-XZ[X^2 + (1+Y)^2 + Z^2]^{-3/2} - 2Z\dot{Y} - XZ\right. \\ &\quad \left.+ XZ[X^2 + (1+Y)^2 + Z^2]^{-3/2}\right\}\end{aligned}\quad (5-10)$$

It is seen that the Lagrange multiplier cancels out of the moment equations. Make a power-series expansion on the gravity term and approximate by dropping terms of higher order than the first to get

$$[X^2 + (1+Y)^2 + Z^2]^{-3/2} \approx 1 - 3Y + \text{Higher-order terms}$$

Then equations (5-8), (5-9), and (5-10) become

$$\bar{M}_{\text{pitch}} \approx m[3XY - 2(X\dot{X} + Y\dot{Y})] \quad (5-11)$$

$$\bar{M}_{\text{roll}} \approx m(2\dot{X}Z - 4YZ) \quad (5-12)$$

$$\bar{M}_{\text{yaw}} \approx m(-XZ - 2Z\dot{Y}) \quad (5-13)$$

It can be seen that in the limiting case where the dumbbell velocity is negligible, the preceding equations reduce to the usual form of gravity-gradient torques for a rotating rectangular coordinate system. The important point here, however, is that the dynamic terms are included. These terms allow an adequate treatment of a rapidly spinning dumbbell.

Equations of Motion of a Single Dumbbell System

Equation (5-6) is

$$P^2 = X^2 + Y^2 + Z^2 = \text{Constant} \quad (5-6)$$

Then the time derivative is

$$2P\dot{P} = 2X\dot{X} + 2Y\dot{Y} + 2Z\dot{Z} = 0$$

and, taking the second time derivative,

$$(X\ddot{X} + Y\ddot{Y} + Z\ddot{Z}) + (\dot{X}^2 + \dot{Y}^2 + \dot{Z}^2) = 0$$

or

$$X\ddot{X} + Y\ddot{Y} + Z\ddot{Z} = -(\dot{X}^2 + \dot{Y}^2 + \dot{Z}^2) \quad (5-14)$$

This relation can then be used to determine the Lagrange multiplier. Multiply equations (5-5) by X , Y , and Z , respectively, and add

$$\left. \begin{aligned}
 \ddot{X} &= 2X\dot{Y} + X^2 - X^2[X^2 + (1+Y)^2 + Z^2]^{-3/2} + 2\lambda X^2 \\
 \ddot{Y} &= -2\dot{X}Y + Y(1+Y) - Y(1+Y)[X^2 + (1+Y)^2 + Z^2]^{-3/2} + 2\lambda Y^2 \\
 \ddot{Z} &= -Z^2[X^2 + (1+Y)^2 + Z^2]^{-3/2} + 2\lambda Z^2
 \end{aligned} \right\} \quad (5-15)$$

Then combining these equations by adding the terms containing the Lagrange multipliers

$$\begin{aligned}
 2\lambda(X^2 + Y^2 + Z^2) &= (\ddot{X} + \ddot{Y} + \ddot{Z}) - 2(X\dot{Y} - Y\dot{X}) - [X^2 + Y(1+Y)] \\
 &\quad + (X^2 + Y^2 + Z^2)[X^2 + (1+Y)^2 + Z^2]^{-3/2} \\
 &\quad + Y[X^2 + (1+Y)^2 + Z^2]^{-3/2}
 \end{aligned}$$

When the right-hand side of equation (5-14) is substituted for the first term on the right and this equation is solved for λ , the result is

$$\begin{aligned}
 \lambda &= -\frac{\dot{X}^2 + \dot{Y}^2 + \dot{Z}^2}{2(X^2 + Y^2 + Z^2)} - \frac{X\dot{Y} - Y\dot{X}}{X^2 + Y^2 + Z^2} - \frac{X^2 + Y(1+Y)}{2(X^2 + Y^2 + Z^2)} \\
 &\quad + \frac{1}{2}[X^2 + (1+Y)^2 + Z^2]^{-3/2} + \frac{Y[X^2 + (1+Y)^2 + Z^2]^{-3/2}}{2(X^2 + Y^2 + Z^2)} \quad (5-16)
 \end{aligned}$$

This expression acts to constrain the length of the dumbbell to a constant value. Thus it serves as a measure of the dumbbell tension components in the X, Y, and Z directions due to the gravity-gradient and dynamic cross-coupling terms.

If, now, three direction cosines of the dumbbell orientation are defined by

$$\cos \delta_1 = \frac{X}{(X^2 + Y^2 + Z^2)^{1/2}} = \frac{X}{P}$$

$$\cos \delta_2 = \frac{Y}{P}$$

and

$$\cos \delta_3 = \frac{Z}{P}$$

It can be seen very readily from equations (5-5) that the nondimensional tension in the dumbbell is given by

$$T = -\lambda P$$

If the gravity term is expanded, λ reverts to the approximate form

$$\lambda = -\frac{\dot{X}^2 + \dot{Y}^2 + \dot{Z}^2}{2(X^2 + Y^2 + Z^2)} - \frac{X\dot{Y} - Y\dot{X}}{X^2 + Y^2 + Z^2} + \frac{1}{2}(1 - 3Y) - \frac{X^2 + 4Y^2}{2(X^2 + Y^2 + Z^2)} \quad (5-17)$$

If this value of λ is then placed back into equations (5-7) and the gravity terms are expanded in these equations also, equations (5-7) become, approximately,

$$\ddot{X} = 2\dot{Y} + X - \frac{2X(X\dot{Y} - Y\dot{X}) + X(\dot{X}^2 + \dot{Y}^2 + \dot{Z}^2) + X(X^2 + 4Y^2)}{X^2 + Y^2 + Z^2} \quad (5-18)$$

$$\ddot{Y} = -2\dot{X} + 4Y - \frac{2Y(X\dot{Y} - Y\dot{X}) + Y(\dot{X}^2 + \dot{Y}^2 + \dot{Z}^2) + Y(X^2 + 4Y^2)}{X^2 + Y^2 + Z^2} \quad (5-19)$$

$$\ddot{Z} = -\frac{2Z(X\dot{Y} - Y\dot{X}) + Z(\dot{X}^2 + \dot{Y}^2 + \dot{Z}^2) + Z(X^2 + 4Y^2)}{X^2 + Y^2 + Z^2} \quad (5-20)$$

Torque Equations of a Double Dumbbell System

The equations of motion derived in the foregoing section of this chapter can be extended to include the case where the two dumbbells are attached by a suitable gimbal system at their centers of mass. To have a perfectly free attachment would be a trivial case, since neither dumbbell would be able to sense the other, and the results would not be different from the case where each dumbbell is considered separately.

Consider then, two dumbbells attached by a two-gimbal pivot arrangement (as in fig. 5-1) which is free to assume any desired angle but to which torquing motors are attached. The torque applied by either dumbbell becomes a reaction torque on the other dumbbell. Let the subscript 1 apply to the large dumbbell which is assumed to be moving slowly and which simulates a space station or orbiting satellite, and let subscript 2 apply to the smaller, rapidly moving dumbbell which simulates a gyroscope. In order to make the problem as general as possible, it will be assumed that the space station can also be controlled by reaction controls and so forth. The equations of motion of the space station become, with the summations over all external torques,

$$m_1 \left[(X_1 \ddot{Y}_1 - Y_1 \ddot{X}_1) - 3X_1 \dot{Y}_1 + 2(X_1 \dot{X}_1 + Y_1 \dot{Y}_1) \right] = \sum T_k + \sum \Upsilon_k \quad (5-21)$$

in pitch

$$m_1 \left[(Y_1 \ddot{Z}_1 - Z_1 \ddot{Y}_1) - 2\dot{X}_1 Z_1 + 4Y_1 \dot{Z}_1 \right] = \sum T_i + \sum \Upsilon_i \quad (5-22)$$

in roll, and

$$m_1 \left[(X_1 \ddot{Z}_1 - Z_1 \ddot{X}_1) + 2Z_1 \dot{Y}_1 + X_1 \dot{Z}_1 \right] = \sum T_j + \sum \Upsilon_j \quad (5-23)$$

in yaw, where the torques produced against the gyroscope are given by $T_{i,j,k}$ and where external torques (couples) produced by reaction controls, distributed drag, and so forth are represented by $\Upsilon_{i,j,k}$.

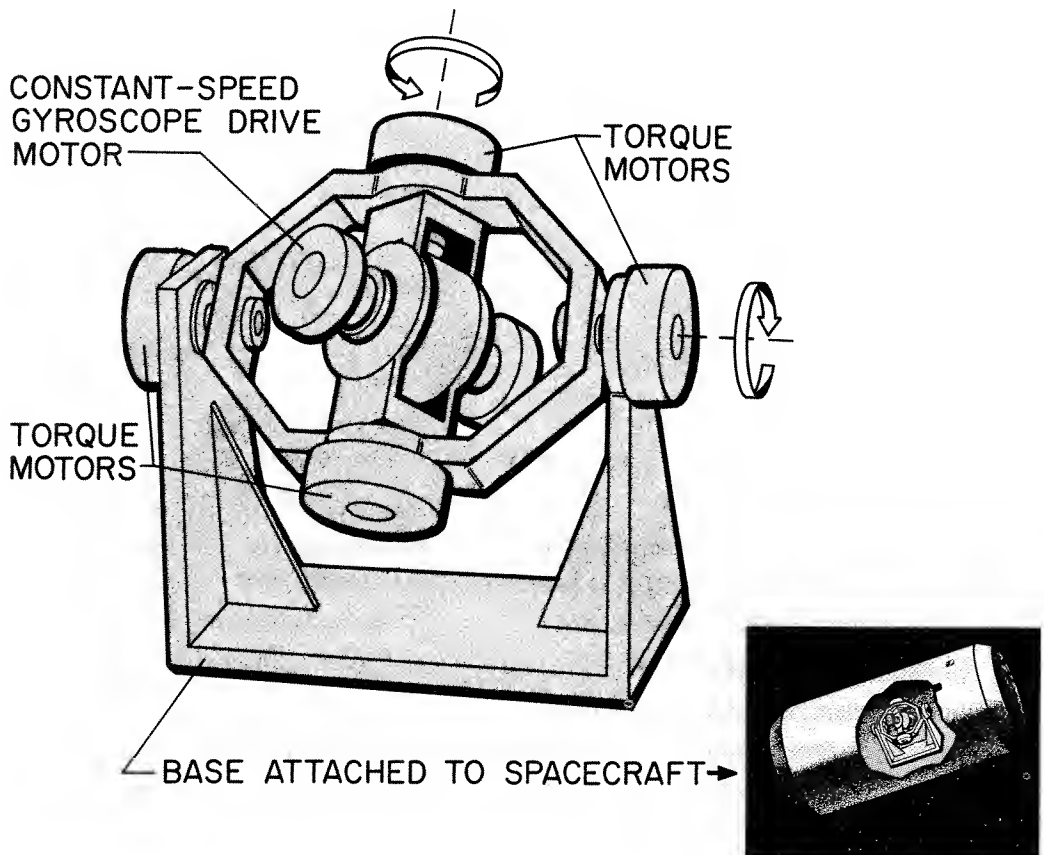

Figure 5-1.- Torquing gimbal assembly.

The equations of motion of the gyroscope become

$$m_2 \left[X_2 \ddot{Y}_2 - Y_2 \ddot{X}_2 - 3X_2 \dot{Y}_2 + 2(X_2 \dot{X}_2 + Y_2 \dot{Y}_2) \right] = - \sum T_k \quad (5-24)$$

$$m_2(\ddot{Y}_2\ddot{Z}_2 - Z_2\ddot{Y}_2 - 2\dot{X}_2\dot{Z}_2 + 4Y_2\dot{Z}_2) = -\sum T_i \quad (5-25)$$

and

$$m_2(\ddot{X}_2\ddot{Z}_2 - Z_2\ddot{X}_2 + 2Z_2\dot{Y}_2 + X_2\dot{Z}_2) = -\sum T_j \quad (5-26)$$

If these three equations are combined by elimination of $T_{i,j,k}$, the resultant equations are

$$\begin{aligned} X_2\ddot{Y}_2 - Y_2\ddot{X}_2 - 3X_2\dot{Y}_2 + 2(X_2\dot{X}_2 + Y_2\dot{Y}_2) = -\left(\frac{m_1}{m_2}\right)[X_1\ddot{Y}_1 - Y_1\ddot{X}_1 - 3X_1\dot{Y}_1 \\ + 2(X_1\dot{X}_1 + Y_1\dot{Y}_1)] + \frac{1}{m_2}\sum r_k \end{aligned} \quad (5-27)$$

$$Y_2\ddot{Z}_2 - Z_2\ddot{Y}_2 - 2\dot{X}_2\dot{Z}_2 + 4Y_2\dot{Z}_2 = -\left(\frac{m_1}{m_2}\right)(Y_1\ddot{Z}_1 - Z_1\ddot{Y}_1 - 2\dot{X}_1\dot{Z}_1 + 4Y_1\dot{Z}_1) + \frac{1}{m_2}\sum r_i \quad (5-28)$$

$$X_2\ddot{Z}_2 - Z_2\ddot{X}_2 + 2Z_2\dot{Y}_2 + X_2\dot{Z}_2 = -\left(\frac{m_1}{m_2}\right)(X_1\ddot{Z}_1 - Z_1\ddot{X}_1 + 2Z_1\dot{Y}_1 + X_1\dot{Z}_1) + \frac{1}{m_2}\sum r_j \quad (5-29)$$

These equations are general except for the highly accurate gravity expansion and contain all of the dynamics of interest.

If it is assumed that there is no thrust from the reaction controls, and it is also assumed that the gyroscope is employed in such a way as to maintain the station in an essentially motionless condition, the station velocity and acceleration terms are negligible in relation to the static gravitational torque term. Under these special conditions the right-hand sides of equations (5-27), (5-28), and (5-29) are dominated by the static gravitational torque, and the other terms can be neglected. Other approximations are also possible on the left-hand sides of these equations. Small dimensions are assumed for the gyroscope; therefore, the static gravitational torque is dropped while the velocity and acceleration terms are retained. The resultant simplified set of equations of motion becomes

$$X_2\ddot{Y}_2 - Y_2\ddot{X}_2 + 2(X_2\dot{X}_2 + Y_2\dot{Y}_2) = \left(\frac{m_1}{m_2}\right)(3X_1\dot{Y}_1) \quad (5-30)$$

$$Y_2\ddot{Z}_2 - Z_2\ddot{Y}_2 - 2\dot{X}_2\dot{Z}_2 = -\left(\frac{m_1}{m_2}\right)(4Y_1\dot{Z}_1) \quad (5-31)$$

$$X_2\ddot{Z}_2 - Z_2\ddot{X}_2 + 2Z_2\dot{Y}_2 = -\left(\frac{m_1}{m_2}\right)(X_1\dot{Z}_1) \quad (5-32)$$

These equations display two important features. First, gravity-gradient terms are still present on the right-hand side of the equations. Second, the gravity-gradient terms affect the motion of the gyroscope in a manner that is magnified by the ratio of the mass of the station to the mass of the gyroscope. This magnification would seem to present a practical limit as to how lightweight space-station control gyroscopes should be since the dynamic terms should be capable of balancing the gravity-gradient terms for any desired station orientation.

It is informative at this stage to summarize briefly the assumptions that have gone into the derivation of equations (5-30), (5-31), and (5-32). First, it was assumed that both station and gyroscope were point-mass dumbbells of fixed length, in orbit, connected at their centers of mass but free to move in all directions subject to a Lagrangian which implied that the gravity gradient had negligible effect upon the circular orbital motion of the center of mass. Next, the two dumbbells were connected in such a way that a torque could be applied by one dumbbell to the other. Thus energy could be supplied from outside the system by torquing motors while producing no change in total angular momentum.

The equations of motion were simplified by expanding the gravity field as in the initial single-dumbbell derivation and subsequently by assuming that the dumbbell which symbolized the gyroscope was physically small compared to the station. It was further assumed that the gyroscope was employed to maintain the space station in an essentially motionless condition which permitted the station velocity and acceleration terms to be neglected. This assumption placed a constraint on the lightness of the gyroscope relative to the space station.

Natural Gyroscope Coordinates

At this stage, both gyroscope and station are expressed in a rectangular coordinate system. The physical situation is easier to understand, however, if the gyroscopic motion is expressed in a coordinate system which is more natural to the gyroscope. A coordinate system more in agreement with those used in classical mechanics is achieved by making the following conversion (see fig. 5-2):

$$X_2 = P_2(\cos \gamma \cos \eta + \sin \gamma \cos \xi \sin \eta) \quad (5-33)$$

$$Y_2 = P_2(\sin \gamma \sin \xi) \quad (5-34)$$

$$Z_2 = P_2(\sin \gamma \cos \xi \cos \eta - \cos \gamma \sin \eta) \quad (5-35)$$

where it should be remembered that X_2 , Y_2 , and Z_2 are already nondimensionalized in terms of r so that this set is an exact analogy with equations (1-100), γ is the angle of m_2 in the gyroscope spin plane from a line where this plane intersects the horizontal plane, η is the angle of intersection of the gyroscope plane with the

horizontal plane as measured from the x-axis, and ξ is the angle between the gyroscope spin vector and the y-axis. This transformation is orthogonal since

$$X_2^2 + Y_2^2 + Z_2^2 = P_2^2$$

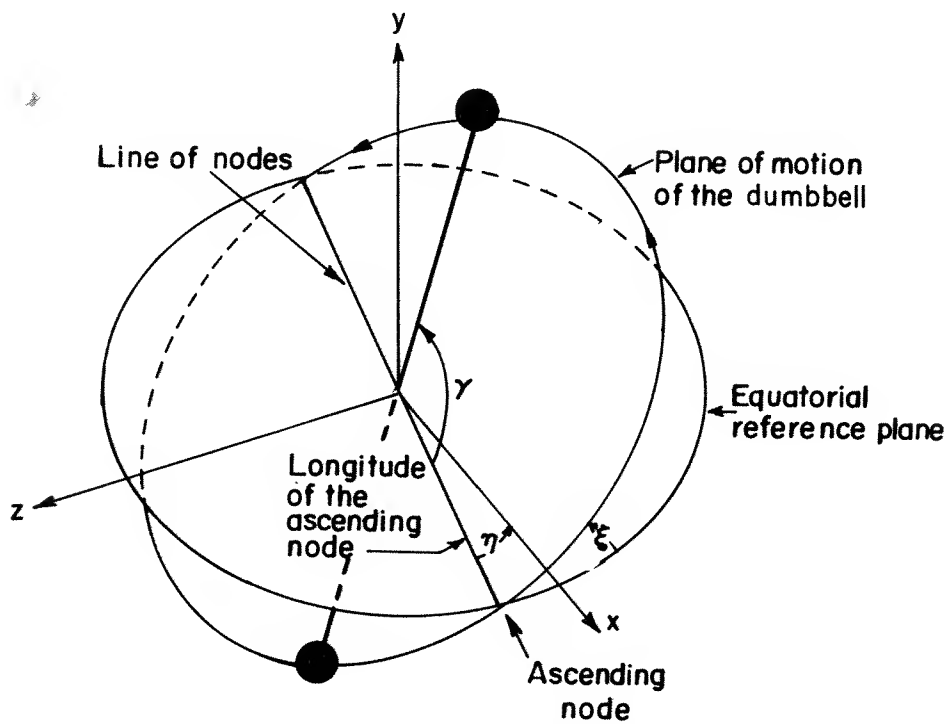

Figure 5-2.- Natural gyroscope coordinates.

Under these conditions the pitch equation becomes

$$\begin{aligned}
 P_2^2 & \left[(\sin \xi \cos \eta) \ddot{\gamma} + (\sin \gamma \cos \gamma \cos \xi \cos \eta + \sin^2 \gamma \sin \eta) \ddot{\xi} + (\sin \gamma \cos \gamma \sin \xi \sin \eta \right. \\
 & - \sin^2 \gamma \sin \xi \cos \xi \cos \eta) \ddot{\eta} - (\sin \gamma \cos \gamma \sin \xi \cos \eta) \dot{\xi}^2 + (\sin \gamma \cos \gamma \sin \xi \cos \eta \\
 & + \sin^2 \gamma \sin \xi \cos \xi \sin \eta) \dot{\eta}^2 + 2(\cos^2 \gamma \cos \xi \cos \eta + \sin \gamma \cos \gamma \sin \eta) \dot{\gamma} \dot{\xi} \\
 & + 2(\sin^2 \gamma \sin^2 \xi \cos \eta) \dot{\eta} \dot{\xi} - 2(\sin \gamma \cos \gamma \sin \xi \cos \xi \cos \eta + \sin^2 \gamma \sin \xi \sin \eta) \dot{\gamma} \dot{\eta} \\
 & + 2(\cos^2 \gamma \cos \xi \sin \eta \cos \eta + \sin \gamma \cos \gamma \cos^2 \xi \sin^2 \eta + \sin \gamma \cos \gamma \sin^2 \xi \\
 & - \sin \gamma \cos \gamma \cos^2 \eta - \sin^2 \gamma \cos \xi \sin \eta \cos \eta) \dot{\gamma} + 2(\sin^2 \gamma \sin \xi \cos \xi \\
 & - \sin \gamma \cos \gamma \sin \xi \sin \eta \cos \eta - \sin^2 \gamma \sin \xi \cos \xi \sin^2 \eta) \dot{\xi} + 2(\sin^2 \gamma \cos^2 \xi \sin \eta \cos \eta \\
 & + \sin \gamma \cos \gamma \cos \xi \cos^2 \eta - \cos^2 \gamma \sin \eta \cos \eta - \sin \gamma \cos \gamma \cos \xi \sin^2 \eta) \dot{\eta} \left. \right] = \frac{m_1}{m_2} (3X_1 Y_1)
 \end{aligned}
 \tag{5-36}$$

The roll equation becomes

$$\begin{aligned}
 P_2^2 & \left[(\sin \xi \sin \eta) \ddot{\gamma} + (\sin \gamma \cos \gamma \cos \xi \sin \eta - \sin^2 \gamma \cos \eta) \ddot{\xi} - (\sin^2 \gamma \sin \xi \cos \xi \sin \eta \right. \\
 & + \sin \gamma \cos \gamma \sin \xi \cos \eta) \ddot{\eta} - (\sin \gamma \cos \gamma \sin \xi \sin \eta) \dot{\xi}^2 + (\sin \gamma \cos \gamma \sin \xi \sin \eta \\
 & - \sin^2 \gamma \sin \xi \cos \xi \cos \eta) \dot{\eta}^2 + 2(\cos^2 \gamma \cos \xi \sin \eta - \sin \gamma \cos \gamma \cos \eta) \dot{\gamma} \dot{\xi} \\
 & + 2(\sin^2 \gamma \sin^2 \xi \sin \eta) \dot{\eta} \dot{\xi} + 2(\sin^2 \gamma \sin \xi \cos \eta - \sin \gamma \cos \gamma \sin \xi \cos \xi \sin \eta) \dot{\gamma} \dot{\eta} \\
 & + 2(\cos^2 \gamma \cos \xi \sin^2 \eta - \sin \gamma \cos \gamma \cos^2 \xi \sin \eta \cos \eta + \sin^2 \gamma \cos \xi \cos^2 \eta \\
 & - \sin \gamma \cos \gamma \sin \eta \cos \eta) \dot{\gamma} + 2(\sin^2 \gamma \sin \xi \cos \xi \sin \eta \cos \eta - \sin \gamma \cos \gamma \sin \xi \sin^2 \eta) \dot{\xi} \\
 & + 2(\sin \gamma \cos \gamma \cos \xi \sin \eta \cos \eta - \sin^2 \gamma \cos^2 \xi \cos^2 \eta + \sin \gamma \cos \gamma \cos \xi \sin \eta \cos \eta \\
 & - \cos^2 \gamma \sin^2 \eta) \dot{\eta} \left. \right] = -\frac{m_1}{m_2} (4Y_1 Z_1)
 \end{aligned}
 \tag{5-37}$$

and the yaw equation becomes

$$\begin{aligned}
 P_2^2 & \left[(\cos \xi) \ddot{\gamma} - (\sin \gamma \cos \gamma \sin \xi) \ddot{\xi} - (\sin^2 \gamma \cos^2 \xi + \cos^2 \gamma) \ddot{\eta} - (\sin \gamma \cos \gamma \cos \xi) \dot{\xi}^2 \right. \\
 & - 2(\cos^2 \gamma \sin \xi) \dot{\gamma} \dot{\xi} + (\sin^2 \gamma \sin \xi \cos \xi) \dot{\eta} \dot{\xi} + 2(\sin \gamma \cos \gamma \sin^2 \xi) \dot{\gamma} \dot{\eta} \\
 & + 2(\sin \gamma \cos \gamma \sin \xi \cos \xi \cos \eta - \cos^2 \gamma \sin \xi \sin \eta) \dot{\gamma} + 2(\sin^2 \gamma \cos^2 \xi \cos \eta \\
 & \left. - \sin \gamma \cos \gamma \cos \xi \sin \eta) \dot{\xi} \right] = -\left(\frac{m_1}{m_2}\right) X_1 Z_1 \quad (5-38)
 \end{aligned}$$

Owing to the choice of this coordinate system the time for one complete revolution of the gyroscope will be very short in relation to the time required for precession or nutation; that is, $\dot{\gamma}$ is much larger than either $\dot{\xi}$ or $\dot{\eta}$. Thus, trigonometric functions of γ can be averaged on the basis that the other parameters are essentially constant over any given single cycle yielding considerable simplification in the equations of motion. It can be readily surmised that the penalty for this approximation consists in ignoring the fast nutation.

For a single turn of the gyroscope through an angle 2π , definite integrals can be used; that is,

$$\int_0^{2\pi} \sin x \, dx = \int_0^{2\pi} \cos x \, dx = 0 \quad (5-39)$$

$$\int_0^{2\pi} \sin x \cos x \, dx = 0 \quad (5-40)$$

$$\int_0^{2\pi} \sin^2 x \, dx = \int_0^{2\pi} \cos^2 x \, dx = \pi \quad (5-41)$$

Hence, the average value of the even terms is

$$\frac{1}{2\pi} \int_0^{2\pi} \sin^2 x \, dx = \frac{1}{2\pi} \int_0^{2\pi} \cos^2 x \, dx = \frac{1}{2} \quad (5-42)$$

and the odd terms vanish. With this spin averaging, the pitch, roll, and yaw equations become, respectively,

$$\begin{aligned}
 P_2^2 & \left[(\sin \xi \cos \eta) \ddot{\gamma} + \frac{1}{2}(\sin \eta) \ddot{\xi} - \frac{1}{2}(\sin \xi \cos \xi \cos \eta) \ddot{\eta} + \frac{1}{2}(\sin \xi \cos \xi \sin \eta) \dot{\eta}^2 \right. \\
 & + (\cos \xi \cos \eta) \dot{\gamma} \dot{\xi} + (\sin^2 \xi \cos \eta) \dot{\eta} \dot{\xi} - (\sin \xi \sin \eta) \dot{\gamma} \dot{\eta} + (\sin \xi \cos \xi - \sin \xi \cos \xi \sin^2 \eta) \dot{\xi} \\
 & \left. - (\sin^2 \xi \sin \eta \cos \eta) \dot{\eta} \right] = \frac{m_1}{m_2} (3X_1 Y_1) \quad (5-43)
 \end{aligned}$$

$$\begin{aligned}
P_2^2 & \left[(\sin \xi \sin \eta) \ddot{\gamma} - \frac{1}{2} (\cos \eta) \ddot{\xi} - \frac{1}{2} (\sin \xi \cos \xi \sin \eta) \ddot{\eta} - \frac{1}{2} (\sin \xi \cos \xi \cos \eta) \dot{\eta}^2 \right. \\
& + (\cos \xi \sin \eta) \dot{\gamma} \dot{\xi} + (\sin \xi \cos \eta) \dot{\gamma} \dot{\eta} + (\sin^2 \xi \sin \eta) \dot{\eta} \dot{\xi} + (\cos \xi) \dot{\gamma} \\
& \left. + (\sin \xi \cos \xi \sin \eta \cos \eta) \dot{\xi} - (\cos^2 \xi \cos^2 \eta + \sin^2 \eta) \dot{\eta} \right] = \frac{m_1}{m_2} (4Y_1 Z_1) \quad (5-44)
\end{aligned}$$

and

$$\begin{aligned}
P_2^2 & \left[(\cos \xi) \ddot{\gamma} - \frac{1}{2} (\cos^2 \xi + 1) \ddot{\eta} - (\sin \xi) \dot{\gamma} \dot{\xi} + (\sin \xi \cos \xi) \dot{\eta} \dot{\xi} - (\sin \xi \sin \eta) \dot{\gamma} \right. \\
& \left. + (\cos^2 \xi \cos \eta) \dot{\xi} \right] = -\frac{m_1}{m_2} (X_1 Z_1) \quad (5-45)
\end{aligned}$$

The gyroscope is now specified by slowly varying parameters which define the position of the spin axis as a function of time.

Separation of the acceleration terms can be accomplished as follows: Multiply the pitch equation by $\cos \xi \cos \eta$, the roll equation by $\cos \xi \sin \eta$, and the yaw equation by $\sin \xi$; add the two former and subtract the latter to obtain

$$\begin{aligned}
P_2^2 & \left[\frac{1}{2} (\sin \xi) \ddot{\eta} + \dot{\gamma} \dot{\xi} + (\sin \eta) \dot{\gamma} - (\cos \xi \sin \eta) \dot{\eta} \right] \\
& = \frac{m_1}{m_2} (3X_1 Y_1 \cos \xi \cos \eta - 4Y_1 Z_1 \cos \xi \sin \eta + X_1 Z_1 \sin \xi) \quad (5-46)
\end{aligned}$$

Then multiply the pitch equation by $\sin \eta$ and the roll equation by $\cos \eta$ and subtract

$$\begin{aligned}
P_2^2 & \left[\frac{1}{2} \ddot{\xi} + \frac{1}{2} (\sin \xi \cos \xi) \dot{\eta}^2 - (\sin \xi) \dot{\gamma} \dot{\eta} - (\cos \xi \cos \eta) \dot{\gamma} + (\cos^3 \eta) \dot{\eta} \right] \\
& = \frac{m_1}{m_2} (3X_1 Y_1 \sin \eta + 4Y_1 Z_1 \cos \eta) \quad (5-47)
\end{aligned}$$

Finally, multiply the pitch equation by $\sin \xi \cos \eta$, the roll equation by $\sin \xi \sin \eta$, and the yaw equation by $\cos \xi$. Add these to obtain

$$\begin{aligned}
P_2^2 & \left[\ddot{\gamma} - (\cos \xi) \ddot{\eta} + (\sin \xi) \dot{\xi} \dot{\eta} + (\cos \xi \cos \eta) \dot{\xi} - (\sin \xi \sin \eta) \dot{\eta} \right] \\
& = \frac{m_1}{m_2} (3X_1 Y_1 \sin \xi \cos \eta - 4Y_1 Z_1 \sin \xi \sin \eta - X_1 Z_1 \cos \xi) \quad (5-48)
\end{aligned}$$

These equations represent the motion of the gyroscope when employed to hold a space station that is under the influence of a gravity-gradient field stationary. The solution of equation (5-46) gives the precession rate, the solution of equation (5-47) gives the nutation rate, and the solution of equation (5-48) gives the change in spin speed resulting from conditions on the station specified by X_1 , Y_1 , and Z_1 . If other control maneuvers are to be made, the more general relationships for station motion and acceleration may be required as given in equations (5-27), (5-28), and (5-29). Solutions of equations (5-36), (5-37), and (5-38) with the more general expressions for station effects would give the torque program required by reference back to equations (5-24), (5-25), and (5-26).

Equations (5-46), (5-47), and (5-48) can also be written in terms of moments of inertia. If

$$I_2 = m_2 P_2^2$$

is the nondimensional principal moment of inertia of the gyroscope dumbbell and

$$I_{1XY} = m_1 X_1 Y_1$$

$$I_{1YZ} = m_1 Y_1 Z_1$$

$$I_{1XZ} = m_1 X_1 Z_1$$

are the respective cross products of inertia of the station, then

$$\begin{aligned} & \frac{1}{2}(\sin \xi)\ddot{\eta} + \dot{\gamma}\dot{\xi} + (\sin \eta)\dot{\gamma} - (\cos \xi \sin \eta)\dot{\eta} \\ & = \frac{3I_{1XY}}{I_2} \cos \xi \cos \eta - \frac{4I_{1YZ}}{I_2} \cos \xi \sin \eta + \frac{I_{1XZ}}{I_2} \sin \xi \end{aligned} \quad (5-46a)$$

$$\begin{aligned} & \frac{1}{2}\ddot{\xi} + \frac{1}{2}(\sin \xi \cos \xi)\dot{\eta}^2 - (\sin \xi)\dot{\gamma}\dot{\eta} - (\cos \xi \cos \eta)\dot{\gamma} + (\cos^3 \eta)\dot{\eta} \\ & = \frac{3I_{1XY}}{I_2} \sin \eta + \frac{4I_{1YZ}}{I_2} \cos \eta \end{aligned} \quad (5-47a)$$

and

$$\begin{aligned} & \ddot{\gamma} - (\cos \xi)\ddot{\eta} + (\sin \xi)\dot{\xi}\dot{\eta} + (\cos \xi \cos \eta)\dot{\xi} - (\sin \xi \sin \eta)\dot{\eta} \\ & = \frac{3I_{1XY}}{I_2} \sin \xi \cos \eta - \frac{4I_{1YZ}}{I_2} \sin \xi \sin \eta - \frac{I_{1XZ}}{I_2} \cos \xi \end{aligned} \quad (5-48a)$$

These equations apply either dimensionalized or not since they involve the ratio of the inertias as the only dimensional terms.

Langley Research Center,
National Aeronautics and Space Administration,
Hampton, Va., March 19, 1973.

SYMBOLS

a	constant defined as $\cos \gamma_b - \frac{K_2}{\beta} y_b$
a	constant of integration which describes amplitude of departure from reference circular orbit
b	constant defined as $\frac{K_2}{\beta}$
C	constant
C_D	drag coefficient
C_L	lift coefficient
D	drag force
E	eccentric anomaly
g	gravitational acceleration
g_e	earth gravitational acceleration
H	total energy per unit mass
H_s	scale height
h	angular momentum per unit mass
h	height above surface of earth
h_a	maximum (apogee) altitude attained by vehicle
h_p	minimum (perigee) altitude attained by vehicle
I_1	moment of inertia of gyroscope in spin
$I_2 = I_3$	moment of inertia of gyroscope perpendicular to spin axis
i,j,k	orthogonal coordinates
K	integration constant defined in equation (4-34)

K_1	constant defined as $\frac{C_D \rho_e S}{2m}$
K_2	constant defined as $\frac{C_L \rho_e S}{2m}$
L	Lagrangian, potential energy subtracted from kinetic energy
L	lift force in chapter 2
L/D	lift-drag ratio
M	mean anomaly
M	translation substitution used to solve equation (4-52) and defined in equation (4-57)
m	mass of vehicle
m	mass of dumbbell when single or of station-gyroscope combination when two dumbbells are present
P	orbital period
p	pressure
$Q(y_0)$	function defined in equation (4-113)
q	dynamic pressure
R	radial distance from space station to vehicle
r	distance from center of planet to orbital vehicle
r_e	radius of earth
r_m	radius of attracting body
r_s	distance from center of attracting body to reference orbit
S	surface area of entry vehicle
s	distance traveled

t	time
u	dummy variable, $a \cos \xi$
V	velocity
V	substitution variable used to solve equation (4-51)
V_{cir}	circular satellite velocity at surface of earth
W	weight of entry vehicle
X,Y,Z	nondimensional coordinates of shell coordinate system centered on a body moving in a circular orbit about an attracting planet or satellite
x,y,z	dimensional coordinates of shell coordinate system centered on a body moving in a circular orbit about an attracting planet or satellite
\bar{Y}	function of a , b , and y defined by equation (2-50a)
y	function of altitude, $e^{-\beta h}$
α	angle of attack
α, β, λ	functions of initial velocity component in x-direction defined in equation (4-35)
β	decay constant of atmosphere
Γ	function defined by equations (2-56a), (2-56b), and (2-56c) depending on conditions
γ	flight-path angle
γ	spin angle of gyroscope dumbbell from line of nodes
γ, η, κ	constant functions of initial out-of-plane velocity defined in equation (4-72)
Δ	function of a power expansion in ρ defined in equation (4-75)
ϵ	eccentricity
ξ	arbitrary constant of integration which describes epoch angle with respect to reference circular orbit

$\zeta(V)$	function of velocity, $\frac{g}{v^2} \left(\frac{v^2}{gr} - 1 \right) \cos \gamma$
η	angle between line of nodes and x-axis measured in x-z plane
Θ	range measured in angle about center of earth
θ	angular coordinate in a cylindrical system with origin at center of attracting body and lying in plane-of-reference circular orbit, measured from positive x-direction clockwise
ϑ	angle formed by x-axis and projection of R on orbital plane of space station
λ	Lagrange multiplier
μ	gravitational constant
ξ	angle between y-axis and angular-momentum vector of gyroscope
P	nondimensional semilength of dumbbell
ρ	density of atmosphere
ρ	function of α , β , and λ defined in equation (4-55); hence, a function of initial velocity and position in x-direction only
ρ	nondimensional radius defined by equation (3-88)
ρ	semilength of dumbbell
τ	nondimensionalized or scaled time, ωt
τ_1	time to rendezvous
ϕ	ejection angle
ψ	function of a power expansion in ρ defined in equation (4-75)
ψ	angle formed by R and orbital plane of space station
$\bar{\Omega}$	directional angular velocity
ω	angular velocity (magnitude)

Subscripts:

a	apogee or highest trajectory point
b	breakout, or exit, condition
c	computed
e	earth
i,j,k	orthogonal coordinates
m	moon
max	maximum
o	initial condition
p	perigee or lowest trajectory point
s	station position or location of origin
v	vehicle
1	space station
2	gyroscope

Dots over symbols denote differentiation with respect to time or scaled time depending upon the section of the book in which they appear. Primes refer to first-order-solution quantities. The tilde \sim represents nondimensionalization with respect to the semimajor axis.

For constants, any consistent set of units may be used. In this paper the following values were chosen:

$$g_e = 9.807 \text{ m/sec}^2$$

$$r_e = 6378.15 \text{ km}$$

$$r_m = 1736.5 \text{ km}$$

$$r_s = r_m + 200 = 1936.5 \text{ km}$$

$$\beta = 0.13666 \text{ per km}$$

$$\mu = 4.8936 \times 10^{12} \text{ m}^3/\text{sec}^2$$

$$V_{\text{cir}} = 7848.62 \text{ m/sec}$$

$$\rho = 1.225 \text{ kg/m}^3$$

REFERENCES

1. Kurth, Rudolf: Introduction to the Mechanics of the Solar System. Pergamon Press, Inc., 1959.
2. Moulton, Forrest Ray: An Introduction to Celestial Mechanics. Second rev. ed., Macmillan Co., c.1914.
3. Dunning, Robert S.: Study of a Guidance Scheme Using Approximate Solutions of Trajectory Equations To Control the Aerodynamic Skip Flight of a Reentry Vehicle. NASA TN D-1923, 1963.
4. Wang, Kenneth; and Ting, Lu: Approximate Solutions for Reentry Trajectories With Aerodynamic Forces. PIBAL Rep. No. 647 (Contract No. AF 49(638)-445), Polytech. Inst. Brooklyn, May 1961.
5. Eggleston, John M.; and Beck, Harold D.: A Study of the Positions and Velocities of a Space Station and a Ferry Vehicle During Rendezvous and Return. NASA TR R-87, 1961.
6. Clohessy, W. H.; and Wiltshire, R. S.: Terminal Guidance System for Satellite Rendezvous. J. Aerosp. Sci., vol. 27, no. 9, Sept. 1960, pp. 653-658, 674.
7. Eggleston, John M.; and Dunning, Robert S.: Analytical Evaluation of a Method of Midcourse Guidance for Rendezvous With Earth Satellites. NASA TN D-883, 1961.
8. London, Howard S.: Second Approximation to the Solution of the Rendezvous Equations. AIAA J., vol. 1, no. 7, July 1963, pp. 1691-1693.
9. Anthony, Maurice L.; and Sasaki, Frank T.: The Rendezvous Problem for Nearly Circular Orbits. Paper No. 65-32, Amer. Inst. Aeronaut. Astronaut., Jan. 1965.
10. Dunning, Robert Scott: Determination of Orbit of a Spacecraft With Respect to an Object in a Known Circular Orbit. NASA TN D-3518, 1966.
11. Margenau, Henry; and Murphy, George Moseley: The Mathematics of Physics and Chemistry. Second ed., D. Van Nostrand Co., Inc., c.1956.
12. Sparrow, Gene W.; and Price, Douglas B.: Derivation of Approximate Equations for Solving the Planar Rendezvous Problem. NASA TN D-4670, 1968.
13. Landau, L. D.; and Lifshitz, E. M. (J. B. Sykes and J. S. Bell, transl.): Mechanics. Pergamon Press, c.1960.

BIBLIOGRAPHY

Books

In addition to the references listed, the following books provide a useful background for further studies:

Arnold, Ronald N.; and Maunder, Leonard: Gyrodynamics and Its Engineering Applications. Academic Press, Inc., 1961.

Baker, Robert M. L., Jr.: Astrodynamics. Academic Press, Inc., 1967.

Berman, Arthur I.: The Physical Principles of Astronautics. John Wiley & Sons, Inc., c.1961.

Bogoliubov, N. N.; and Mitropolsky, Y. A.: Asymptotic Methods in the Theory of Non-Linear Oscillations. Gordon & Breach Sci. Publ., Inc., 1961.

Brouwer, Dirk; and Clemence, Gerald M.: Methods of Celestial Mechanics. Academic Press, Inc., c.1961.

Champion, K. S. W.: U.S. Supplementary Atmospheres. AFCRL 66-564, U.S. Air Force, 1966.

Clarke, Arthur C.: The Promise of Space. Harper & Row, Publ., c.1968.

Cole, Julian D.: Perturbation Methods in Applied Mathematics. Blaisdell Pub. Co., c.1968.

Craig, Richard A.: The Upper Atmosphere – Meteorology and Physics. Academic Press, Inc., c.1965.

Danby, J. M. A.: Fundamentals of Celestial Mechanics. Macmillan Co., c.1962.

Davis, Harold T.: Introduction to Nonlinear Differential and Integral Equations. U.S. At. Energy Comm., Sept. 1960.

Heiskanen, W. A.; and Vening Meinesz, F. A.: The Earth and Its Gravity Field. McGraw-Hill Book Co., Inc., 1958.

King-Hele, Desmond: Theory of Satellite Orbits in an Atmosphere. Butterworth, Inc., 1964.

Kovalevsky, Jean: Introduction à la mécanique céleste. Librairie Armand Colin (Paris), c.1963.

Lass, Harry: Vector and Tensor Analysis. McGraw-Hill Book Co., Inc., 1950.

Lindsay, Robert Bruce: Physical Mechanics. D. Van Nostrand Co., Inc., c.1933.

Loh, W. H. T.: Dynamics and Thermodynamics of Planetary Entry. Prentice-Hall, Inc., 1963.

Martin, John J.: Atmospheric Reentry. Prentice-Hall, Inc., c.1966.

McCuskey, S. W.: Introduction to Celestial Mechanics. Addison-Wesley Pub. Co., Inc., c.1963.

- McLachlan, N. W.: Ordinary Non-Linear Differential Equations in Engineering and Physical Sciences. Second ed., Clarendon Press (Oxford), 1958.
- Meirovitch, Leonard: Methods of Analytical Dynamics. McGraw-Hill Book Co., Inc., c.1970.
- Mueller, Ivan I.: Introduction to Satellite Geodesy. Frederick Ungar Pub. Co., c.1964.
- Müller, Rolf: Die Planeten und Ihre Monde. Springer-Verlag, c.1966.
- Page, Leigh: Introduction to Theoretical Physics. Third ed., D. Van Nostrand Co., Inc., c.1952.
- Phillips, H. B.: Vector Analysis. John Wiley & Sons, Inc., 1933.
- Plummer, H. C.: An Introductory Treatise on Dynamical Astronomy. Dover Publ., Inc., 1960.
- Poincaré, H.: Les Méthodes Nouvelles de la Mécanique Céleste. Tomes I-III, Dover Publ., Inc., 1957.
- Rosser, J. Barkely, ed.: Space Mathematics. Pts. 1-3. Amer. Math. Soc., 1966.
- Roy, Archie E.: The Foundations of Astrodynamics. Macmillan Co., c.1965.
- Siegel, Carl Ludwig: Vorlesungen Über Himmelsmechanik. Springer-Verlag, 1956.
- Smart, W. M.: Celestial Mechanics. Longmans, Green and Co., 1953.
- Smart, W. M.: Text-Book on Spherical Astronomy. Cambridge Univ. Press, 1956.
- Sommerfeld, Arnold (Martin O. Stern, transl.): Mechanics. Academic Press, Inc., 1952.
- Sterne, Theodore E.: An Introduction to Celestial Mechanics. Interscience Publ., Inc., 1960.

Research Reports

In addition to the foregoing list of books, the following is a list of important research reports. Since the volume of material in this form is large, only those that seem most significant and those that best tend to cover gaps in the text material are included. The reader should bear in mind that this can only be a partial listing at best:

- Anon.: Orbital Flight Handbook. NASA SP-33, Pts. 1-3, 1963.
- Armstrong, E. S.; and Suddath, J. H.: Application of Pontryagin's Maximum Principle to the Lunar Orbit Rendezvous Problem. AIAA Paper No. 63-361, 1963.
- Beletskii, V. V.: Relative Motion of a Link-Up of Two Objects in Orbit. II. Cosmic Res., vol. 7, no. 6, Nov.-Dec. 1969, pp. 745-755.
- Beletskii, V. V.; and Novikova, E. T.: Relative Motion of a Link-Up of Two Objects in Orbit. Cosmic Res., vol. 7, no. 3, May-June 1969, pp. 340-346.

- Bender, D. F.; and Blackford, A. L.: Guidance, Flight Mechanics and Trajectory Optimization. Vol. XII - Relative Motion, Guidance Equations for Terminal Rendezvous. NASA CR-1011, 1968.
- Brereton, R. C.; and Modi, V. J.: On the Stability of Planar Librations of a Dumb-Bell Satellite in an Elliptic Orbit. J. Roy. Aeronaut. Soc., vol. 70, no. 672, Dec. 1966, pp. 1098-1102.
- Cochran, John Euell, Jr.: On the Effects of Gravity-Gradient Torque on the Rotational Motion of a Triaxial Artificial Satellite. AMRL 1021, Univ. of Texas at Austin, Aug. 1970.
- Eggleston, John M.: A Study of the Optimum Velocity Change to Intercept and Rendezvous. NASA TN D-1029, 1962.
- Fleig, Albert J., Jr.: On the Libration of a Gravity Gradient Stabilized Spacecraft in an Eccentric Orbit. NASA TR R-350, 1970.
- Fleming, Alan W.; and DeBra, Daniel B.: The Stability of Gravity-Stabilized Drag-Free Satellites. AIAA Paper No. 70-995, Aug. 1970.
- Greenberg, M. S.: Momentum-Management Systems. Bendix Tech. J., vol. 1, Spring 1968, pp. 61-69.
- Hartbaum, H. K.: Flywheel-Augmented Gravity Gradient Stabilization. Astrodynamics Guidance and Control, Michał Żunc, P. Contensou, G. N. Duboshin, and W. F. Hilton, eds., Gordon & Breach, Inc., 1967, pp. 193-202.
- Hempel, Peter: Ausdehnung des Hohmann-Übergangs auf nicht-koaxiale elliptische Bahnen. Astronaut. Acta, vol. 13, no. 3, May-June 1967, pp. 205-212.
- Hohmann, Walter: The Attainability of Heavenly Bodies. NASA TT-F44, 1960.
- Hunziker, R. R.: Satellite Rendezvous Guidance Using Universal Orbit Variables. Astrodynamics Guidance and Control, Michał Żunc, P. Contensou, G. N. Duboshin, and W. F. Hilton, eds., Gordon & Breach, Inc., 1967, pp. 235-246.
- Ives, N. E.: A Two-Gyro Semi-Passive Attitude Control System for Earth Pointing Satellites. Tech. Rep. 67078, Brit. R.A.E., Mar. 1967. (Available from DDC as AD 666 522.)
- Kane, T. R.; and Robe, T. R.: Gravity Torque Effects. AIAA J., vol. 4, no. 8, Aug. 1966, pp. 1454-1455.
- Kurzahls, Peter R.: An Approximate Solution of the Equations of Motion for Arbitrary Rotating Spacecraft. NASA TR R-269, 1967.
- Lawden, Derek F.: Impulsive Transfer Between Elliptical Orbits. Optimization Techniques, George Leitmann, ed., Academic Press, Inc., 1962, pp. 323-351.
- Lewis, J. A.; and Zajac, E. E.: A Two-Gyro, Gravity-Gradient Satellite Attitude Control System. Bell Syst. Tech. J., vol. XLIII, no. 6, Nov. 1964, pp. 2705-2765.

- Liska, Donald J.; and Zimmerman, Ward H.: Effect of Gravity Gradient on Attitude Control of a Space Station. *J. Spacecraft & Rockets*, vol. 2, no. 3, May-June 1965, pp. 419-425.
- Loh, W. H. T.: Extension of the Second Order Theory of Entry Mechanics to Nearly Exact Solutions. AIAA Paper No. 66-488, June 1966.
- Marchal, Christian: Transferts Optimaux Entre Orbites Elliptiques. (Durée Indifférente). ONERA Publ. No. 120, 1967.
- Marec, J. P.: Optimal Transfers Between Close Elliptical Orbits. NASA TT F-554, 1969.
- Peltier, J. P.; and Balageas, D.: Atmospheric Braking During the Return in Low Orbit of a Recoverable Vehicle. IAF Paper 134, Oct. 1970.
- Schechter, Hans B.: Dumbbell Librations in Elliptic Orbits. AIAA J., vol. 2, no. 6, June 1964, pp. 1000-1003.
- Schindelin, J. W.: On Space Vehicle Attitude Stabilization by Passive Control Moment Gyros. *Ing.-Arch.*, vol. 39, no. 1, 1970, pp. 37-52.
- Staff of Langley Research Center: Performance and Dynamics of Aerospace Vehicles. NASA SP-258, 1971.
- Stapleford, Robert L.: A Study of the Two Basic Approximations in the Impulsive Guidance Techniques for Orbital Rendezvous. ASD-TDR-62-83, U.S. Air Force, July 1962.
- Sun Fang Toh: Analytical Solution for Optimal Two-Impulse 180° Transfer Between Noncoplanar Orbits and the Optimal Orientation of the Transfer Plane. AIAA J., vol. 7, no. 10, Oct. 1969, pp. 1898-1904.
- Tschauner, Johann: The Elliptic Orbit Rendezvous. AIAA Paper No. 66-537, June 1966.
- Tschauner, J.; and Hempel, P.: Rendezvous zu einem in elliptischer Bahn umlaufenden Ziel. *Astronaut. Acta*, vol. 11, no. 2, Mar.-Apr. 1965, pp. 104-109.
- Wang, Kenneth; and Ting, Lu: Approximate Solutions for Reentry Trajectories With Aerodynamic Forces. PIBAL Rep. No. 647 (Contract No. AF 49(638)-445), Polytech. Inst. Brooklyn, May 1961.
- Weber, H. I.; and Schiehlen, W.: Attitude Controllability of a Satellite With Flywheels. *J. Spacecraft & Rockets*, vol. 7, no. 4, Apr. 1970, pp. 501-502.
- Wells, William R.: Notes on Gravitational Potential Theory. Eng. Ext. Ser. Circ. No. 6, Virginia Polytech. Inst., [1966].

INDEX

	Page
angular momentum	
of a point mass in space	7
rate of change for atmospheric entry	42
uncoupling with energy equation	26
Anthony, Maurice L.	69
apogee	8, 104, 107
atmospheric density	
as a function of altitude	29
scale height	29
atmospheric entry equations	
approximate solution of	30-39
barometric equation	27
accuracy of	29
Boltzmann's constant	28
circular orbit	13
angular momentum of	14
energy of	13
speed of	14
Clohessy, W. H.	55
Clohessy-Wiltshire equations	55
in spherical coordinates	89
loss of accuracy over distance and time	56
comets	15
compression (of connected point masses)	125
conic section, equation of	9
difference in angular momentum between parabolic and circular orbits	15
differential corrections	69
distributed drag	130
dumbbell	
direction cosines	128
double dumbbell system	129, 134, 135
simple	124
single dumbbell system	127
dynamic pressure	26

	Page
eccentric anomaly	17
Eggleston, John M.	55
ejection angle	102, 106, 114
ellipse	10
elliptic orbit	11
negative period	13
period of	12
semimajor axis of	13
energy	
negative per unit mass	11
per unit mass	8
rate of change for atmospheric entry	42
total in shell coordinates	104
uncoupling with angular momentum	26
epoch angle	119
equations of motion	
Anthony and Sasaki's formulation	69-78
approximate in rectangular coordinates for relative motion	54
first order solutions in shell coordinates	43-95
for a simple particle in a point gravitational field	6, 22
for flight in atmosphere	27, 44
for relative motion in rectangular coordinates	51
for relative motion in spherical coordinates	87
for relative motion in shell coordinates	91
Kepler formulation for flight in atmosphere	41, 46
London's formulation	57-69
of a free gyroscope	130
of a gyroscope in a space station	131
in pitch	134
in roll	134
in yaw	134
second order solutions in shell coordinates	96-99
breakdown	103, 114
in dimensional notation	105
escape speed	15
evaluation of integration constants for shell coordinate solutions	100
external torques	129

	Page
gravitational potential	6
in cylindrical coordinates	91
in rectangular coordinates	51
weakening with distance	108
gravity	
comparison between rectangular and shell coordinates	108
expansion in rectangular coordinates	54
expansion in spherical coordinates	88
Newton's law of	5
gravity gradient	127, 132
gyroscope	
in terms of moments of inertia	137
natural coordinates	132
separation of acceleration terms	136
gyroscopic time averaging	135
Hohmann transfer (to the lunar surface)	112
hydrostatic equation	27
hyperbola	10
hyperbolic trajectories	16
energy per unit mass	16
escape from solar system	16
escape into solar system	16
inertial frame of reference	3
Kepler's equation	17
center, equation of	18, 71
launch angle (also see ejection angle)	114
left handed coordinate system	90
Lagrange multiplier	124
Lagrangian	
of a simple particle in a gravity field	6
of a relative motion in moving rectangular coordinates	50
for relative motion in shell coordinates	91
for relative motion in spherical coordinates	83
London, Howard S.	57
mean altitude	108
mean anomaly	16, 71

	Page
mean displacement of orbit	108
meteorite trajectories	15
moments on a single dumbbell	126
pitch	126
roll	126
yaw	127
Newtonian reference frame	3
Newton's laws of motion	3
nonconservative forces	26
orbit	
defining parameters	21
general equation of	10
in space	21
orbital angular rate	14
orthogonal transformation	133
parabola	10
parabolic trajectories	14
total energy	14
speed of	14
perfect gas law	28
perigee	8, 104, 107
perturbations	
anharmonic oscillator	96, 114
Anthony and Sasaki	69-78
London	57-69
potential	
at the surface of a planet	6
between a point mass and a finite rigid body	3
equivalence of point masses and spheres	5
energy of a particle	6
gravitational	6
of a sphere	4
Price, Douglas B.	116
Q factor	119
quadrant and sign selection (a, ζ)	
first order table	95
second order table	101

	Page
ratio of parabolic to circular speed	15
reaction controls	130
reentry theory	24-46
equations of flight in atmosphere	27
flight path angle equation	35
Keplerian formulation with lift and drag	39
range equation	38, 39
speed and flight path angle	25
velocity equation	37
reentry vehicle	24
lift and drag forces on	24, 26
relative velocity in rectangular coordinates	51
rendezvous equations	
in rectangular coordinates	55
in shell coordinates	120
in spherical coordinates	89
of Sparrow and Price	121
Sasaki, Frank T.	69
satellite position in space	22
second harmonic in shell coordinates	108
secular terms	78, 110
semilatus rectum of a conic section	9
shell coordinates	89
skipout	35
Sparrow, Gene W.	116
Sparrow Q factor	119
spherical coordinates	85
synchronous orbit	110
tension of connected point masses	125
torque on a double dumbbell system	129
two-gimbal pivot	129
variation of flight path angle	35
variation of velocity	35
Wiltshire, R. S.	55